

Do



**RULES FOR  
COMPETITION**  
INCORPORATING WORLD  
ATHLETICS RULES

**EFFECTIVE FROM 1ST APRIL  
2020**





**UK ATHLETICS**

**COMPETITION RULES  
FOR USE IN THE UK  
1<sup>st</sup> April 2020 – 31<sup>st</sup> March 2022**

**WORLD ATHLETICS RULES IN FORCE AS FROM  
1ST NOVEMBER 2019**

UK Athletics  
Athletics House  
Alexander Stadium  
Walsall Road  
Perry Barr  
Birmingham B42 2BE

Jason Gardener M.B.E. - President

Tel: 0121 713 8400  
W: [www.uka.org.uk](http://www.uka.org.uk)  
E: [rules@uka.org.uk](mailto:rules@uka.org.uk)

UK Athletics Ltd. ISBN: 978-0-9547401-6-0

## A NEW LOOK FOR UKA RULES

The 2016 - 2018 UKA Rule Book was the first to adopt the IAAF (now World Athletics) format for Rules for Competition. This was achieved by incorporating into the IAAF rule book, as Supplementary Rules to the equivalent IAAF Rule, those additional rules that apply in the UK. This policy has been continued in this 2020 - 2022 Rule Book, although, as World Athletics has now adopted a completely new structure for its rule book, you will note significant differences in format to what has gone before.

The main differences that you will find are:

- Rules have been divided into sections relating to Competition and Technical Rules and renumbered from 1 in each section.
- World Athletics has removed some rules and included them in other sections that are published separately. Where such rules apply to competition in the UK, we have placed them in a UK General section, which follows the Competition and Technical sections. The full set of World Athletics rules can be found at <https://www.worldathletics.org/about-iaaf/documents/book-of-rules>
- Three tables of Rule numbers follow these introductory pages showing the former numbers cross referenced to the new numbers in their respective Competition, Technical and General sections.
- World Athletics continue to omit an index, but, to assist the user in finding the appropriate Rule or UKA Supplement, we have included an expanded index at the back of the Rule Book, using the new Rule numbers (prefixed with a “C” for Competition Rules, a “T” for Technical Rules and a “G” for General Rules).
- Lines down the side of a page indicate where Rule changes have been made.

- Appendices:
  - Appendix 1 – Ultra Rules have been incorporated into Rule G9;
  - the two Officials' Appendices 2 and 3 have been removed from the Rule Book and located at <https://www.uka.org.uk/competitions/rules/>.
  - Appendix 4 – Endurance Running – as in the previous edition (save where specifically indicated). For ease of reference, the appendices titles have been retained in their original format for the period of this edition of the Rule Book.

**TABLE OF CONTENTS**

	<i>Page</i>
A NEW LOOK FOR UKA RULES	2
TABLES OF RULE REFERENCES	7
RULES OF INTERPRETATION	21
DEFINITIONS	28
COMPETITION RULES	37
SECTION I – GENERAL	37
SECTION II – COMPETITION OFFICIALS	44
SECTION III – WORLD RECORDS	79
TECHNICAL RULES	99
SECTION I – GENERAL	99
SECTION II – TRACK EVENTS	140
SECTION III – FIELD EVENTS	198
A. VERTICAL JUMPS	209
B. HORIZONTAL JUMPS	227
C. THROWING EVENTS	236
SECTION IV – COMBINED EVENTS COMPETITIONS	290
SECTION V – INDOOR COMPETITIONS	295
SECTION VI – RACE WALKING EVENTS	305
SECTION VII – ROAD RACES	313
SECTION VIII – CROSS-COUNTRY, MOUNTAIN AND TRAIL RACES	323
UKA GENERAL RULES	336
INDEX OF TECHNICAL RULES	396

## **OFFICERS OF UKA GROUPS**

### **UK ATHLETICS ADVISORY GROUPS**

#### **COMPETITION STRATEGY**

Contact: Donna Fraser, UKA, Alexander Stadium, Walsall Road, Perry Barr, Birmingham, B42 2BE; Tel: 0121 713 8400; E: [DFraser@uka.org.uk](mailto:DFraser@uka.org.uk)

#### **TECHNICAL**

Chair: Moira Gallagher, UKA, Alexander Stadium, Walsall Road, Perry Barr, Birmingham, B42 2BE; Tel: 0121 713 8400; E: [gallagherm@supanet.com](mailto:gallagherm@supanet.com)

#### **OFFICIALS GROUP**

Coordinator: Andrew Clatworthy, 26 Columba Drive, Leighton Buzzard, Beds. LU7 3YN; Tel: 01525 371186; E: [ajc.athletics@btinternet.com](mailto:ajc.athletics@btinternet.com)

#### **UKA RULES GROUP**

Tim Soutar (Chair), Donna Fraser, Chris Cohen CBE, Keith Davies, Peter Crawshaw, Moira Gallagher, Arwel Williams, John Temperton (Administrator)

Contact: John Temperton, UKA, Alexander Stadium, Walsall Road, Perry Barr, Birmingham, B42 2BE; Tel: 0121 713 8400; E: [rules@uka.org.uk](mailto:rules@uka.org.uk)

#### **ENDURANCE**

Contact: Karen Forbes, UKA, Alexander Stadium, Walsall Road, Perry Barr, Birmingham, B42 2BE; Tel: 0121 713 8400; E: [KForbes@britishathletics.org.uk](mailto:KForbes@britishathletics.org.uk)



## NATIONAL ASSOCIATIONS

### ENGLAND ATHLETICS

Alexander Stadium, Walsall Road, Perry Barr, Birmingham, B42 2BE;  
Tel: 0121 347 6543; Fax: 0121 347 6544; [www.Englandathletics.org](http://www.Englandathletics.org)

#### Tri-Regional Officials:

**South:** David Vidler, 4 Quarter Gate, South Woodham Ferrers, Chelmsford, Essex, CM3 5GT; Tel: 01245 323179; E: [miveld.vidler@btinternet.com](mailto:miveld.vidler@btinternet.com)

**Midlands & South West:** Barry Parker, 26 Field Drive, Alvaston, Derby, DE24 0HF; Tel: 01332 753933; E: [parkerbarry47@gmail.com](mailto:parkerbarry47@gmail.com)

**North:** John Driscoll, 90 Greenside Kendal, LA9 5DT; Tel: 07974 015751;  
E: [vetcoachjohn@gmail.com](mailto:vetcoachjohn@gmail.com)

### ATHLETICS NORTHERN IRELAND

Athletics House, Old Coach Road, Belfast, BT79 5PR; Tel: 028 9060 2707;  
Fax: 028 9030 9939; [www.niathletics.org](http://www.niathletics.org)

**Officials' Development:** Liz Glover, 61 Ardenlee Avenue, Belfast, BT6 0AB;  
E: [lizglover@hotmail.co.uk](mailto:lizglover@hotmail.co.uk)

### SCOTTISH ATHLETICS LTD

Caledonia House, South Gyle, Edinburgh, EH12 9DQ; Tel: 0131 539 7320;  
[www.scottishathletics.org.uk](http://www.scottishathletics.org.uk)

**Officials' Convenor:** Margaret Brown, 15 Glenside Court, Armadale, West Lothian, EH48 3RX; Tel: 07903 207802; E: [mbb626@hotmail.co.uk](mailto:mbb626@hotmail.co.uk)

### WELSH ATHLETICS LTD

Cardiff International Sports Stadium, Leckwith Road, Cardiff, CF11 8AZ;  
Tel: 029 2064 4870; Fax: 029 1034 2687; [www.welshathletics.org](http://www.welshathletics.org)

**Officials' Convenor (Track & Field):** Sue Hooper, 28 Mill Common, Undy, Caldicot, Monmouthshire, NP26 3JH; Tel: 01633 881608;  
E: [hooper\\_pencoed@btinternet.com](mailto:hooper_pencoed@btinternet.com)

**Endurance Officials' Secretary:** Contact Welsh Athletics at  
[office@welshathletics.org](mailto:office@welshathletics.org)

## **SPECIFIC UKA DOMESTIC RULES**

**THESE ARE SHOWN IN PURPLE FOLLOWING THE  
APPROPRIATE WORLD ATHLETICS RULE**

### **UKA APPENDICES**

#### **Rule**

Appendix 1: Rules for Ultra Distance Road & Track Races

Moved to Rule G9

Appendix 2: Technical Officials' Pathway (Track & Field)

Now at <https://www.uka.org.uk/competitions/rules/>

Appendix 3: Appointment of, Duties of & Selection of Officials

Now at <https://www.uka.org.uk/competitions/rules/>

Appendix 4: Endurance Running.

UKA has accepted that IPC Rules for Competition will apply to Disability competitions held in the UK. IPC Rules are available at <http://www.paralympic.org/athletics/rules-and-regulations/rules> and on request from UKA.

The Board of UKA retain the right to apply appropriate Rules changes within the period this rule book covers. Should any changes be made information will be published on the UKA website at <http://www.uka.org.uk/competitions/rules/> and directly by e-mail to licensed Technical Officials.

**TABLES OF RULE REFERENCES**

<b>BOOK C – C1.1 – COMPETITION RULES</b>		
<b>Rule Name</b>	<b>Previous Rule Reference</b>	<b>New Rule Reference</b>
<b>Part I – General</b>		
Authorisation to Stage Competitions	Rule 2	RULE 1 of the Competition Rules or CR1
Regulations Governing the Conduct of International Competitions	Rule 3	RULE 2 of the Competition Rules or CR2
<b>Part II – Competition Officials</b>		
International Officials	Rule 110	RULE 3 of the Competition Rules or CR3
Organisational Delegates	Rule 111	RULE 4 of the Competition Rules or CR4
Technical Delegates	Rule 112	RULE 5 of the Competition Rules or CR5
Medical Delegates	Rule 113	RULE 6 of the Competition Rules or CR6

<b>BOOK C – C1.1 – COMPETITION RULES</b>		
<b>Rule Name</b>	<b>Previous Rule Reference</b>	<b>New Rule Reference</b>
Anti- Doping Delegates	Rule 114	RULE 7 of the Competition Rules or CR7
International Technical Officials (ITOs)	Rule 115	RULE 8 of the Competition Rules or CR8
International Race Walking Judges (IRWJs)	Rule 116	RULE 9 of the Competition Rules or CR9
International Road Course Measurers	Rule 117	RULE 10 of the Competition Rules or CR10
International Starters and International Photo Finish Judges	Rule 118	RULE 11 of the Competition Rules or CR11
Jury of Appeal	Rule 119	RULE 12 of the Competition Rules or CR12
Officials of the Competition	Rule 120	RULE 13 of the Competition Rules or CR13
Competition Director	Rule 121	RULE 14 of the Competition Rules or CR14

<b>BOOK C – C1.1 – COMPETITION RULES</b>		
<b>Rule Name</b>	<b>Previous Rule Reference</b>	<b>New Rule Reference</b>
Meeting Manager	Rule 122	RULE 15 of the Competition Rules or CR15
Technical Manager	Rule 123	RULE 16 of the Competition Rules or CR16
Event Presentation Manager	Rule 124	RULE 17 of the Competition Rules or CR17
Referees	Rule 125	RULE 18 of the Competition Rules or CR18
Judges	Rule 126	RULE 19 of the Competition Rules or CR19
Umpires (Running and Race Walking Events)	Rule 127	RULE 20 of the Competition Rules or CR20
Timekeepers, Photo Finish Judges and Transponder Timing Judges	Rule 128	RULE 21 of the Competition Rules or CR21
Start Coordinator, Starter, Recallers	Rule 129	RULE 22 of the Competition Rules or CR22

<b>BOOK C – C1.1 – COMPETITION RULES</b>		
<b>Rule Name</b>	<b>Previous Rule Reference</b>	<b>New Rule Reference</b>
Starter's Assistants	Rule 130	RULE 23 of the Competition Rules or CR23
Lap Scorers	Rule 131	RULE 24 of the Competition Rules or CR24
Competition Secretary, Technical Information Centre (TIC)	Rule 132	RULE 25 of the Competition Rules or CR25
Marshal	Rule 133	RULE 26 of the Competition Rules or CR26
Wind Gauge Operator	Rule 134	RULE 27 of the Competition Rules or CR27
Measurement Judge (Scientific)	Rule 135	RULE 28 of the Competition Rules or CR28
Call Room Judges	Rule 136	RULE 29 of the Competition Rules or CR29
Advertising Commissioner	Rule 137	RULE 30 of the Competition Rules or CR30

<b>Part III – World Records</b>		
World Records	Rule 260	RULE 31 of the Competition Rules or CR31
Events for which World Records are Recognised	Rule 261	RULE 32 of the Competition Rules or CR32
Events for which World U20 Records are Recognised	Rule 262	RULE 33 of the Competition Rules or CR33
Events for which World Indoor Records are Recognised	Rule 263	RULE 34 of the Competition Rules or CR34
Events for which World U20 Indoor Records are Recognised	Rule 264	RULE 35 of the Competition Rules or CR35
Other Records	Rule 265	RULE 36 of the Competition Rules or CR36

<b>BOOK C – C2.1 – TECHNICAL RULES</b>		
<b>Rule Name</b>	<b>Previous Rule Reference</b>	<b>New Rule Reference</b>
<b>Part I – General</b>		
General	Rule 100	RULE 1 of the Technical Rules or TR1

<b>BOOK C – C2.1 – TECHNICAL RULES</b>		
<b>Rule Name</b>	<b>Previous Rule Reference</b>	<b>New Rule Reference</b>
The Athletics Facility	Rule 140	RULE 2 of the Technical Rules or TR2
Age and Sex Categories	Rule 141	RULE 3 of the Technical Rules or TR3
Entries	Rule 142	RULE 4 of the Technical Rules or TR4
Clothing, Shoes, and Athlete Bibs	Rule 143	RULE 5 of the Technical Rules or TR5
Assistance to Athletes	Rule 144	RULE 6 of the Technical Rules or TR6
Effect of Disqualification	Rule 145	RULE 7 of the Technical Rules or TR7
Protests and Appeals	Rule 146	RULE 8 of the Technical Rules or TR8
Mixed Competition	Rule 147	RULE 9 of the Technical Rules or TR9



<b>BOOK C – C2.1 – TECHNICAL RULES</b>		
<b>Rule Name</b>	<b>Previous Rule Reference</b>	<b>New Rule Reference</b>
Surveying and Measurements	Rule 148	RULE 10 of the Technical Rules or TR10
Validity of Performance	Rule 149	RULE 11 of the Technical Rules or TR11
Video Recording	Rule 150	RULE 12 of the Technical Rules or TR12
Scoring	Rule 151	RULE 13 of the Technical Rules or TR13
<b>Part II – Track Events</b>		
Track Measurements	Rule 160	RULE 14 of the Technical Rules or TR14
Starting Blocks	Rule 161	RULE 15 of the Technical Rules or TR15
The Start	Rule 162	RULE 16 of the Technical Rules or TR16
The Race	Rule 163	RULE 17 of the Technical Rules or TR17

<b>BOOK C – C2.1 – TECHNICAL RULES</b>		
<b>Rule Name</b>	<b>Previous Rule Reference</b>	<b>New Rule Reference</b>
The Finish	Rule 164	RULE 18 of the Technical Rules or TR18
Timing and Photo Finish	Rule 165	RULE 19 of the Technical Rules or TR19
Seedings, Draws and Qualifications in Track Events	Rule 166	RULE 20 of the Technical Rules or TR20
Ties	Rule 167	RULE 21 of the Technical Rules or TR21
Hurdle Races	Rule 168	RULE 22 of the Technical Rules or TR22
Steeplechase Races	Rule 169	RULE 23 of the Technical Rules or TR23
Relay Races	Rule 170	RULE 24 of the Technical Rules or TR24
<b>Part III – Field Events</b>		
General Conditions – Field Events	Rule 180	RULE 25 of the Technical Rules or TR25

<b>BOOK C – C2.1 – TECHNICAL RULES</b>		
<b>Rule Name</b>	<b>Previous Rule Reference</b>	<b>New Rule Reference</b>
General Conditions – Vertical Jumps	Rule 181	RULE 26 of the Technical Rules or TR26
High Jump	Rule 182	RULE 27 of the Technical Rules or TR27
Pole Vault	Rule 183	RULE 28 of the Technical Rules or TR28
General Conditions – Horizontal Jumps	Rule 184	RULE 29 of the Technical Rules or TR29
Long Jump	Rule 185	RULE 30 of the Technical Rules or TR30
Triple Jump	Rule 186	RULE 31 of the Technical Rules or TR31
General Conditions – Throwing Events	Rule 187	RULE 32 of the Technical Rules or TR32
Shot Put	Rule 188	RULE 33 of the Technical Rules or TR33

<b>BOOK C – C2.1 – TECHNICAL RULES</b>		
<b>Rule Name</b>	<b>Previous Rule Reference</b>	<b>New Rule Reference</b>
Discus Throw	Rule 189	RULE 34 of the Technical Rules or TR34
Discus Cage	Rule 190	RULE 35 of the Technical Rules or TR35
Hammer Throw	Rule 191	RULE 36 of the Technical Rules or TR36
Hammer Cage	Rule 192	RULE 37 of the Technical Rules or TR37
Javelin Throw	Rule 193	RULE 38 of the Technical Rules or TR38
<b>Part IV – Combined Events Competitions</b>		
Combined Events Competitions	Rule 200	RULE 39 of the Technical Rules or TR39
<b>Part V – Indoor Competitions</b>		
Applicability of Outdoor Rules to Indoor Competitions	Rule 210	RULE 40 of the Technical Rules or TR40
The Indoor Stadium	Rule 211	RULE 41 of the Technical Rules or TR41

<b>BOOK C – C2.1 – TECHNICAL RULES</b>		
<b>Rule Name</b>	<b>Previous Rule Reference</b>	<b>New Rule Reference</b>
The Straight Track	Rule 212	RULE 42 of the Technical Rules or TR42
The Oval Track and Lanes	Rule 213	RULE 43 of the Technical Rules or TR43
Start and Finish on the Oval Track	Rule 214	RULE 44 of the Technical Rules or TR44
Seedings, Draw for Lanes in Track Events	Rule 215	RULE 45 of the Technical Rules or TR45
Clothing, Shoes and Athlete Bibs	Rule 216	RULE 46 of the Technical Rules or TR46
Hurdle Races	Rule 217	RULE 47 of the Technical Rules or TR47
Relay Races	Rule 218	RULE 48 of the Technical Rules or TR48
High Jump	Rule 219	RULE 49 of the Technical Rules or TR49

<b>BOOK C – C2.1 – TECHNICAL RULES</b>		
<b>Rule Name</b>	<b>Previous Rule Reference</b>	<b>New Rule Reference</b>
Pole Vault	Rule 220	RULE 50 of the Technical Rules or TR50
Horizontal Jumps	Rule 221	RULE 51 of the Technical Rules or TR51
Shot Put	Rule 222	RULE 52 of the Technical Rules or TR52
Combined Events Competitions	Rule 223	RULE 53 of the Technical Rules or TR53
<b>Part VI – Race Walking Events</b>		
Race Walking	Rule 230	RULE 54 of the Technical Rules or TR54

<b>Part VII – Road Races</b>		
Road Races	Rule 240	RULE 55 of the Technical Rules or TR55
<b>Part VIII – Cross Country, Mountain and Trail Races</b>		
Cross Country Races	Rule 250	RULE 56 of the Technical Rules or TR56
Mountain and Trail Races	Rule 251	RULE 57 of the Technical Rules or TR57

<b>UKA General Rules and Supplements not Linked to World Athletics Competition or Technical Rules</b>		
Payments to Athletes	Rule 6	Rule G6
Athletes' Representatives	Rule 7	Rule G7
Advertising	Rule 8	Rule G8
Definition of an Eligible Athlete	Rule 20	Rule G1
Eligibility to Compete	Rule 21	Rule G2
Ineligibility	Rule 23	Rule G3
Anti-Doping	Rule 30	Rule G4
Betting	Rule 60	Rule G5
Endurance Running Appendix	App 4	App 4
Ultra Running Rules	App 1	Rule G9
Technical Officials Guidance	App 2 & 3	Now at <a href="https://www.uka.org.uk/competitions/rules/">https://www.uka.org.uk/competitions/rules/</a>

*Notes:*

- **Green text:** The notes in green print provide interpretation to the Rules and practical guidance for their implementation.
- **Double lines:** The double lines in the margin correspond to amendments (other than editorial) to the corresponding Rule that have been approved by Council.
- **Single Lines:** The single lines in the margin correspond to amendments to the corresponding UKA Supplementary Rule.



## **RULES OF INTERPRETATION**

These Rules of Interpretation, set out principles of interpretation, other general provisions, and definitions, that apply to all Rules and Regulations (whether issued before or after these Rules of Interpretation come into effect), unless specifically stated otherwise in a specific Rule or Regulation.

### ***General Principles of Interpretation***

In the event of any inconsistency between the Constitution and any other Rules or Regulations, the Constitution shall prevail.

The Constitution, Rules, and Regulations will be published in English and French, and any other language decided by the Chief Executive Officer. In the event of any inconsistency between the English version and any other version, the English version shall prevail.

Rules and Regulations are to be interpreted and applied in a manner that protects and advances their respective purposes. In the event that a matter arises that is not foreseen in the Rules or Regulations in issue, it shall be addressed in the same manner.

In the event of a question arising at any time on a matter not provided for in, or as to the meaning or proper interpretation or application of any Rules or Regulations, Council may determine the same, by reference to the purpose(s) of the Rules or Regulations in issue.

In all Rules and Regulations, unless expressly specified otherwise:

- words importing one gender include the other genders;
- words in the singular include the plural, and words in the plural include the singular;
- references to Clauses, Paragraphs, Schedules and Appendices are, unless otherwise stated, references to clauses, paragraphs,

schedules, and appendices to those Rules or Regulations (as applicable);

- any reference to a provision in a Rule or Regulation includes any modifications or successor provisions made or issued from time to time;
- any reference to the International Athletics Association Federation (or IAAF) shall mean the World Athletics, formerly the International Athletics Association Federation (or IAAF).
- any reference to legislation includes any modification or re-enactment of legislation enacted in substitution of that legislation, and any regulation, order-in-council or other instrument from time to time issued or made under that legislation;
- any reference to an agreement includes that agreement as modified, supplemented, novated or substituted from time to time;
- a reference to "writing" or "write" includes fax and email;
- a reference to "may" shall mean "in the sole discretion of such person";
- Unless otherwise defined, a reference to a person includes natural persons, corporate bodies, and unincorporated bodies (whether or not having separate legal personality), and also includes the legal personal representatives, successors and permitted assigns of such person;
- a reference to a "day" means any day of the week and is not limited to working days;
- an expression of time refers to Central European Standard Time;
- headings and tables of content are for reference only and shall not affect the proper interpretation and application of the Rules or Regulations in question;

- schedules and appendices form an integral part of the Rules or Regulations to which they are scheduled/appended, but if there is any inconsistency between any provisions in the main body of the Rules or Regulations and the content of the schedules or appendices, the provisions in the main body of the Rules or Regulations shall prevail;
- where commentary is provided, it is to be used as an aid to the proper interpretation of the provision(s) on which it is commenting; and
- any words following the terms "including", "include", "in particular", "such as", "for example", or any similar expression, shall be construed as illustrative and shall not limit the sense of the words, description, definition, phrase or term preceding those terms.

### ***General Provisions***

Since the Rules and Regulations apply globally, insofar as possible they are to be interpreted and applied not by reference to particular national or local laws, but rather by reference to general principles of law common to most if not all legal systems. Subject thereto, the Rules and Regulations are governed by and are to be interpreted and applied in accordance with the laws of Monaco (excluding its conflict of law rules).

If any provision or part-provision of any Rules or Regulations is or becomes invalid, illegal or unenforceable, it shall be deemed deleted, but that shall not affect the validity, legality and enforceability of the rest of the Rules or Regulations.

Where a Rule or Regulation refers to a decision to be taken by the World Athletics, without further specifying the decision-making body, that decision shall be made by Council, or by its chosen delegate.

Where a Rule or Regulation confers a power or imposes a duty on the holder of an office, that power shall be exercised, or the duty is to be performed, by the holder for the time being of the office, unless delegated to another person where the holder is properly authorised to delegate such powers.

Any deviation from the provisions of any Rules or Regulations by an officer or other representative of World Athletics and/or any irregularity, omission, or other defect in the procedures followed by such officer or other representative shall not invalidate any finding, procedure or decision unless it is shown to render that finding, procedure or decision unreliable.

***Notifications:***

Save where expressly specified otherwise, any notification to be given under a Rule or Regulation to World Athletics, without further specifying the body or person to whom the notification is to be given, is only sufficiently given if it is made in writing, in English or French, and delivered by electronic mail to [notices@worldathletics.org](mailto:notices@worldathletics.org). For the avoidance of doubt, this rule does not apply to the service of any process or other documents in any litigation or arbitration or other external dispute resolution proceedings of any kind.

Any notification to be given under a Rule or Regulation by a person (the “Notifying Party”) will be deemed to have been sufficiently given to the party to whom the notice is required to be given (the “Receiving Party”) if it is made in writing and signed or authorised by an authorised person of the Notifying Party and delivered by one of the following means to the Receiving Party:

- by post to the last known address of the Receiving Party;
- by personal delivery, including by courier, to the published physical address of the Receiving Party;
- by electronic mail, to the published email address of the Receiving Party; or
- by facsimile to the published facsimile number of the Receiving Party.

***Deadlines and time limits:***

Any deadline or time limit that is stated in a Rule or Regulation to run from notification shall be deemed to start running on the day on which the notification is delivered. Any deadline or time limit that is stated in a Rule or Regulation to run from the happening of another event or the doing of an act or thing shall be deemed to start running on the day after the happening of the event or the doing of the act or thing.

Official holidays and non-working days are included in the calculation of deadlines and time limits, save where they would be the last day of the deadline or time limit in question, in which case the last day of that deadline or time limit will be the next day that is not an official holiday or non-working day.

A deadline or time limit will be deemed to have been complied with if the notification is delivered or other act or thing is done before midnight Central European Standard Time on the day on which the deadline or time limit expires.

***Transitional provisions:***

Rules and Regulations shall come into effect on the date specified by Council, unless specified otherwise.

Council may amend, supplement, replace or revoke Rules or Regulations from time to time, as it sees fit. Such amendments and/or supplementary and/or replacement provisions shall come into effect on the date specified by Council.

Unless expressly specified otherwise, Rules and Regulations (including amendments and supplementary or replacement provisions) shall apply retroactively if they are procedural, but if they are substantive they shall not apply retroactively, but rather only to matters arising after they come into effect. Instead, any matter that is pending as of the date the Rules or Regulations come into effect, and any matter that arises after that date but relates to facts occurring prior to that date, shall be governed by the

substantive provisions of the Rules and Regulations in force prior to that date, unless the principle of *lex mitior* applies.

***Generally Applicable Definitions***

Unless a contrary intention appears, defined words and defined terms used in these Rules of Interpretation and/or in any other Rules and Regulations shall be denoted by starting with capital letters, and shall have the meaning set out in the Generally Applicable Definitions, or the meaning given to them in the Constitution.

## DEFINITIONS

### GENERALLY APPLICABLE DEFINITIONS

These Generally Applicable Definitions, are the definitions of certain commonly used terms, that apply to the Constitution and all Rules and Regulations (whether issued before or after these Rules of Interpretation come into effect), unless specifically stated otherwise in the Constitution or any specific Rule or Regulation.

#### ***Anti-Doping Rules***

Anti-Doping Rules which came into effect on 1 November 2019 as amended from time to time.

#### ***Area Association***

The association of Member Federations and other members in an Area established and operating in accordance with the Constitution and the Rules.

#### ***Area***

The geographical areas described in the Annexure to the Constitution.

#### ***Article***

An Article of the Constitution.

#### ***Athlete***

Unless specified otherwise, any Person who is entered for, or participating in, an Athletics event or competition of World Athletics, its Members or Area Associations by virtue of their agreement, membership, affiliation, authorisation, accreditation, entry or participation.

#### ***Athlete Representative***

A person who is duly authorised and registered as an Athletes Representative in accordance with the Athletes Representatives Rules and Regulations.

#### ***Athlete Support Personnel***

Unless specified otherwise, any coach, trainer, manager, authorised Athlete Representative, agent, team staff, official, medical or para-medical personnel, parent or any other Person working with, treating or assisting an Athlete participating in, or preparing for, an Athletics event or competition.

***Athletics***

The sport of Athletics as defined in the Rules and Regulations including track and field, road running, race walking, cross-country running, mountain running, and trail running.

***Athletics Integrity Unit***

The unit described in Part X of this Constitution and “Integrity Unit” has the same meaning.

***CAS***

The Court of Arbitration for Sport which is an independent arbitration body seated in Lausanne, Switzerland.

***Citizen***

A person that has legal citizenship of a Country, or in the case of a Territory, legal citizenship of the Territory’s parent Country and appropriate legal status in the Territory under the applicable laws.

***Competition***

Event or series of Events held over one or more days.

***Constitution***

Unless stated otherwise, the constitution of World Athletics which came into effect on 1 January 2019 including any amendments to it made from time to time. World Athletics Constitution has the same meaning.

***Council***

The body described in Part V of the Constitution.

***Council Member***

Any member of Council including the President and Vice-Presidents, Area President, Individual Council Members and their Chair and other members of the Athletes' Commission, (whether an ex officio member or otherwise), unless specifically provided otherwise in this Constitution.

***Country***

A self-governing geographical area of the world recognised as an independent state by international law and international governmental bodies.

***Delegate***

Unless stated otherwise, a person elected or appointed by a Member Federation to represent it at Congress.



***Disciplinary Tribunal***

The judicial body established to hear and decide all breaches of the Integrity Code of Conduct in accordance with the Rules and Regulations and such other matters as set out in the Constitution, Rules or Regulations.

***Election Oversight Panel***

The Panel which has oversight of the candidacies of persons seeking election by Congress as a Council Member and the proper administration of such election.

***Ethics Board***

The independent judicial body established by World Athletics under the Previous Constitution and which ceases to exist, except to the extent set out in the Rules for matters under its jurisdiction under the Previous Constitution.

***Executive Board***

The body described in Part VII of the Constitution.

***Executive Board Members***

Unless specified otherwise, the members of the Executive Board elected and appointed under the Constitution.

***Former Code of Ethics***

The former Code of Ethics of World Athletics containing principles of ethical conduct and related rules and procedures as revoked and replaced with the Integrity Code of Conduct with effect from 3 April 2017 except to the extent expressly provided for in the Rules for transition purposes.

***Integrity Code of Conduct***

The code of conduct described in Article 75 of the Constitution as amended from time to time.

***Integrity Unit***

The body described in Part X of this Constitution. Also has the same meaning as the "Athletics Integrity Unit".

***International Competitions***

Unless otherwise specified, the following international competitions:

- 1.1 (a) Competitions included in the World Athletics Series.
- (b) The Athletics programme of the Olympic Games.

- 1.2 The Athletics programme of Area, Regional or Group Games not confined to participants from a single Area where World Athletics does not have exclusive control.
- 1.3 Regional or Group Championships in Athletics not confined to participants from a single Area.
- 1.4 Matches between teams from different Areas representing Members or Areas or combinations thereof.
- 1.5 International Invitation Meetings and competitions that are categorised by World Athletics as part of the global structure and approved by the Council.
- 1.6 Area Championships and other intra-Area competitions organised by an Area Association.
- 1.7 The Athletics programme of Area, Regional or Group Games, and Regional or Group Championships in Athletics confined to participants from a single Area.
- 1.8 Matches between teams representing two or more Members of combinations thereof within the same Area, with the exception of U18 and U20 category competitions.
- 1.9 International Invitation Meetings and competitions, other than those referred to in Rule 1.1(e), where appearance fees, prize money and/or the value of non-cash prizes exceed USD 50,000 in total, or USD 8,000 for any one event.
- 1.10 Area programmes similar to those referred in (1.6).

***International Level Athlete***

Unless stated otherwise, an Athlete who is entered for or is competing in an International Competition.

***IOC***

The International Olympic Committee which is the international non-governmental and non-profit organisation responsible for the Olympic movement, including the Olympic Games, under the Olympic Charter.

***Members***

The members of World Athletics as described in Article 6, also known as Member Federations, and as listed in the Annexure, as updated from time to time and "Membership" means being a Member of World Athletics.

***Major Event Organisation***

Any international multi-sport organisation (e.g., the IOC) that acts as the ruling body for any continental, regional or other International Competition.

***Member Federation***

The national governing body for the sport of Athletics in a Country or territory which has been admitted to membership to World Athletics.

***Officials***

Any person who is elected or appointed to a position in which they represent World Athletics (whether as an independent or otherwise), including, but not limited to Council Members, Executive Board Members, members of the Disciplinary Tribunal, members of the Integrity Unit Board, members of the Integrity Unit Board Appointments Panel, members of the Executive Board Appointments Panel, members of the Vetting Panel, members of Commissions and Working Groups, members of any other bodies or panels established by World Athletics, and consultants and advisors to World Athletics, unless specifically provided otherwise.

***Person***

Any natural person (including any Athlete or Athlete Support Personnel) or an organisation or other entity.

***Regulations***

All regulations approved from time to time by Council within its powers and responsibilities which shall not be inconsistent with the Constitution and the Rules.

***Rule***

A principle, instruction, direction, standard or procedure approved from time to time by Council within its powers and responsibilities, which shall not be inconsistent with the Constitution. A reference to 'a' Rule (singular) means the Rule in which the reference to the Rule is made, unless stated otherwise.

***Rules***

All rules approved from time to time by Council within its powers and responsibilities, including the Integrity Code of Conduct, which shall not be inconsistent with the Constitution.

***Territory***

A geographical area of the world which is not a Country, but which has aspects of self-government, at least to the extent of being autonomous in the control of its sport, and which is recognised as such by the World Athletics.

***Vetting***

The process whereby it is decided if an Applicant or Existing World Athletics Official is Eligible to be, or remain in office as, a World Athletics Official in accordance with the Constitution, the Rules and Regulations.

***Vetting Rules***

The rules of World Athletics which set out the procedure for Vetting all Applicants and Existing World Athletics Officials (as described in those Rules).

***WADA***

The World Anti-Doping Agency, a body founded by the IOC and constituted as a foundation in Lausanne by an instrument of foundation signed on November 1999 and named in that instrument as the Agency Mondiale Antidopage, World Anti-Doping Agency.

***World Athletics***

The association of the Member Federations which is the international authority for the sports of Athletics worldwide, formerly known as the International Association of Athletics Federations (IAAF).

***World Athletics Series***

The major International Competitions in World Athletics' four-yearly official competition programme such as the World Athletics Championships, World Athletics Indoor Championships, World Athletics U20 Championships, World Athletics Relays, World Athletics Half Marathon Championships, World Athletics Race Walking Team Championships, World Athletics Cross Country Championships, and World Athletics Continental Cup, and "World Athletics Series Event" or "WAS Event" means any one of these events.

## **UKA SUPPLEMENT**

### **UKA PREAMBLE & DEFINITIONS**

UK Athletics Rules for Competition, supported by the Articles of Association, define affiliation to a National Association as a prerequisite for entry to competition. The National Associations to which these apply are: England Athletics Ltd, Athletics Northern Ireland Ltd, Scottish Athletics Ltd. and Welsh Athletics Ltd.

These Associations will operate and maintain affiliation and registration schemes, including the responsibility to levy club affiliation and athlete registration fees, and are required to describe the conditions associated with such fees from time to time.

Membership of clubs or individuals with UK Athletics is granted automatically on affiliation to any of the National Associations. UK Athletics has delegated responsibility for governance functions to the National Associations.

Other Organisations, Associations or Competition Providers within the sport may request that a Club should become a member of that Competition Provider in order to participate in its activities.

UKA have adopted IAAF rules for the regulation of the sport of Athletics unless hereinafter varied.

The Board of UK Athletics is responsible for the interpretation of UKA Rules, and the final adjudication of any dispute.

#### **Definitions:**

The following terms used throughout the Rules are defined here:

#### ***Area***

A geographical sub-division of England (Midlands, North and South) having a separate Committee for competition purposes only.

#### ***British Athletics***

The consumer brand of the governing body UK Athletics.

#### ***Club***

Affiliated Club including affiliated University, College, School or Services Unit.

***Competition Provider***

Any organisation approved by UKA that is authorised to promote Athletics competition in the UK. Those organisations listed in these definitions are deemed to be authorised Competition Providers.

***County Association***

A further sub-division of England having a separate Committee for competition purposes only.

***Development Event***

An event that is being trialled for a particular age group / gender and which has not previously been specified in UKA Rules for that age group / gender.

***District***

A geographical sub-division of Scotland having a separate Committee for administrative purposes.

***Licence***

Written authority to promote an event granted by UKA or a National Association applying the terms and standards currently in force.

***Licensing Authority***

A body with delegated powers from UKA to issue competition licences.

***National Association (hereafter referred to as ‘Association’)***

England Athletics Ltd, Athletics Northern Ireland Ltd, Scottish Athletics, Welsh Athletics Ltd.

***Region***

A smaller unit of England Athletics for administrative purposes.

***SAPCA***

Sports and Play Construction Association (hereafter referred to as “SAPCA”). A trade association whose members who provide wide range of products and services for the sports and play facility construction industry.

***UK Athletics (UKA)***

The Member Federation of World Athletics responsible for athletics in the United Kingdom of Great Britain and Northern Ireland.

Where the words ‘must’ and ‘shall’ are used the Rule is compulsory. Where ‘should’ is employed, while UK Athletics expects that the Rule will be observed, strict compliance is not essential.

The Rules for Competition cover all disciplines of athletics.

The management of Fell, Hill and Mountain Running is delegated to National Committees:

- (a) Fell Runners' Association Ltd. (England)
- (b) Scottish Athletics Ltd. Hill Running Commission
- (c) Welsh Athletics Ltd.
- (d) Northern Ireland Mountain Running Association

The management of Trail Running in England is delegated to the Trail Running Association. All other Home Nations are managed via the National Associations.

## COMPETITION RULES

### SECTION I – GENERAL

#### **RULE 1 AUTHORISATION TO STAGE COMPETITIONS**

1. World Athletics is responsible for supervising a global competition system in cooperation with the Area Associations. World Athletics shall coordinate its competition calendar and those of the respective Area Associations in order to avoid or minimise conflicts. All International Competitions must be authorised by World Athletics or an Area Association in accordance with this Rule 1. Any combination or integration of International Meetings into a Series / Tour or League requires a permit from World Athletics or the concerned Area Association including the necessary regulation or contractual condition for such an activity. The operation may be delegated to a third party. In the event that an Area Association fails properly to manage and control International Competitions in accordance with these Rules, World Athletics shall be entitled to intervene and take such steps as it deems necessary.
2. World Athletics alone shall have the right to organise the Athletics competition at the Olympic Games and the competitions that are included in the World Athletics Series.
3. World Athletics shall organise a World Championships in odd-numbered years.
4. Area Associations shall have the right to organise Area Championships and they may organise such other intra-Area events as they deem appropriate.
5. Competitions Requiring a World Athletics Permit:
  - 5.1. A World Athletics permit is required for all International Competitions listed paragraphs 1.2, 1.3, 1.4 and 1.5 of the International Competition definition.
  - 5.2. An application for a permit must be made to the Chief Executive Officer by the Member in whose Country or Territory the International Competition is to take place not later than 12 months prior to the competition, or such other



deadline as may be established by the Chief Executive Officer.

6 Competitions Requiring an Area Association Permit

- 6.1. An Area Association Permit is required for all International Competitions listed in paragraphs 1.7, 1.8, 1.9, and 1.10 of the International Competition definition. Permits for International Invitation Meetings or competitions where appearance fees, prize money and/or the value of non-cash prizes exceed USD 250,000 in total, or USD 25,000 for any one event, shall not be issued prior to the Area Association's consultation with the Chief Executive Officer regarding the date.
- 6.2. An application for a permit must be made to the appropriate Area Association by the Member in whose Country or Territory the International Competition is to take place not later than 12 months prior to the competition, or such other deadline as may be established by the Area Association.

Competitions Authorised by a Member:

7. Members may authorise national competitions, and foreign athletes may participate in those competitions, subject to the Requirements to Compete in International Competition Rules. If foreign athletes do participate, appearance fees, prize money, and/or non-cash prizes for all athletes at such national competitions shall not exceed USD 50,000 in total, or USD 8,000 for any one event. No athlete may participate in any such competition if they are ineligible to participate in the sport of Athletics under the rules of World Athletics, the host Member, or the Member Federation to which they are affiliated.

**RULE C1 (2) S 1 UKA SUPPLEMENT**  
**PERMISSION TO PROMOTE**

- (1) This Rule applies to all disciplines of athletics as defined in Rule G2 S2(4).
- (2) All events, other than those identified in (3) below, require Licences as set out below
- (3) Provided they conform to UKA Rules for Competition the following athletic events do not require specific permission:
  - (i) Events promoted by, and confined to employees (and their relatives) of any particular business entity.
  - (ii) Events promoted by, and confined to, HM Services.
  - (iii) Events promoted by, and confined to members of schools or an Education Authority, pre-service organisation or other recognised juvenile organisation, provided that the relevant National or County Association is affiliated to the appropriate National Association.
  - (iv) Track and Field Events classified as Level 1 where recognition of performances is not required.

*NOTE: Explanation for the divisions into Competition Levels is available in diagram form at <http://uka.org.uk/competitions/track-field-licensing/>*

- (4) Permission to promote will be granted by UK Athletics. UKA may make such procedural arrangements (including delegation to other bodies) for the administration of its powers as it sees necessary. It shall hereinafter be called the Licensing Authority.
- (5) The Licensing Authority shall publish the conditions for licences to be granted which may be varied from time to time.
- (6) Applications for permission to promote must be made on the standard form approved for the purpose and be accompanied by the appropriate fee. The submission to the Licensing Authority shall contain such additional information as that Authority may reasonably require. The Licensing Authority has discretion whether to grant or refuse permission and shall be entitled to apply to a grant of permission such conditions as it thinks appropriate.
- (7) Applications must be made at least eight weeks before the proposed date of the event.
- (8) Applications must include undertakings by the applicant to:
  - (i) Adopt and comply with UKA Rules for Competition.

- (ii) Include the words ‘Under UKA Rules’ upon all advertising, programmes and printed material issued in connection with the athletic event.
  - (iii) Organise and manage the event to the appropriate standard and comply with any additional requirements or conditions of the Licensing Authority.
  - (iv) Clearly display the Licence at the venue and be available for inspection.
- (9) Any Body that promotes or is involved in the promotion of any athletics event in contravention of this Rule shall be liable to disciplinary action by the National Association, and any person taking part in such a competition who is aware of any suspension may thereby be liable to disqualification from competing under UKA Rules for a specified time.

## **RULE C1 (2) S 2 UKA SUPPLEMENT UKA LICENCES**

- (1) TRACK and FIELD
- (i) Licences are required for Track and Field competitions as indicated below:
    - (a) Competition Providers of competitions classified as Level 2 must obtain a Licence from UKA.
    - (b) Competition Providers of competitions classified as Level 1 held within the boundaries of England, Northern Ireland, Scotland or Wales must obtain a Licence from the appropriate Home Country Association or from UKA for UK wide competitions.
  - (ii) The maximum time allowed for a track and field competition held under a UKA Licence will be 8 hours unless a separate group of officials is provided. The 8 hours will commence at the programmed time of the first event and be completed at the scheduled finish time of the final event.
  - (iii) On the first failure to comply a warning will be issued to the Competition Provider and subsequent failures may result in the withholding of a Licence.

(2) RACE WALKING

All Open Race Walking events require specific permission to stage events. Applications for permission to promote events should be sent together with a fee (as determined by the appropriate issuing authority) to the appropriate Honorary Secretary:

- (i) For events to be held in England to the RWA Honorary Secretary.
- (ii) For events to be held in Northern Ireland, Scotland or Wales to the appropriate National Association.

An OPEN event is defined as one open to all eligible athletes and all eligible affiliated Clubs, including one restricted to a particular County District and/or age group. (See Rule G2 S6)

(3) CROSS COUNTRY

Any Competition Provider granted a Cross Country Licence by the Licensing Authority must impose, in addition to the basic entry fee, an additional fee of £2 (to be known as the ‘Additional Unattached Entry Fee’) on every entrant in an Open Senior Cross Country race who is not a member of a Club affiliated to a National Association and who does not have a current individual registration with their National Association. Any additional entry fees collected are payable to the Licensing Authority within one month of the date of the competition and must be accompanied by copies of the full entry list and results, if requested.

(4) ROAD RACES

UKA has delegated the responsibility for licensing road races to the National Associations and subsequently England Athletics and Welsh Athletics have appointed runbritain to manage the process on their behalf.

- (i) Any Competition Provider affiliated to a National Association wishing to hold a road race must:
  - (a) Consult the Local Authority Safety Advisory Group or equivalent and inform the relevant Local Authorities and Emergency Services
  - (b) Obtain a Road Race Licence from the UKA Licensing Authority
  - (c) Comply with the requirements of UKA Licence Standards.

- (ii) The following shall be deemed to be a race under UKA Rules and will require the issue of a Road Race Licence before they can be held:
  - (a) Events in which awards or prizes are given in accordance with the finishing order of runners and/or
  - (b) Events which pay appearance money or otherwise contract athletes to appear.
- (iii) All Competition Providers who wish to stage any road race must apply for a UKA Road Race Licence in the manner specified by the National Association. Failure to comply with the requirements of the Licensing Authority in the issue of a Race Licence may lead to the withholding of future licences to the Competition Provider or such person as the Authority deems fit.
- (iv) The appropriate National Association shall have the power to reduce or waive the Licence Fee or levy collection.
- (v) Any Competition Provider to whom a Road Race Licence has been granted by UKA must:
  - (a) Insert the words 'Under UKA Rules' and the unique Licence Code as issued to the race when the licence is granted, upon all printed matter associated with the Road Race.
  - (b) Grant a minimum discount of £2 from the advertised race entry fee in Senior competitions to a member of a Club affiliated to a National Association and who has a current individual registration with their National Association.
  - (c) Within one month of the race being staged, submit designated reports to meet National Association requirements, including access to entry and result lists, if requested.

(5) FELL, HILL and MOUNTAIN RUNNING

All official UKA Fell, Hill and Mountain Running Races must be registered with one of the National Committees. The registration shall be affected by supplying to the nominated officer of the relevant body details of the race on the form provided and by its subsequent appearance in a published calendar / fixture list / magazine supplement. A nominal charge may be made to cover calendar publication expenses and race insurance.

(6) **TRAIL RACES**

- (i) Competition Providers of Trail Races must obtain a UK Athletics race licence. They are available from the Trail Running Association (TRA) or the appropriate National Association.
- (ii) Any Competition Provider granted a Trail Running Licence by UKA must impose, in addition to the basic entry fee, an additional fee of £2 (to be known as the ‘Additional Unattached Entry Fee’) on every entrant in a Senior Open Trail Running race who is not a member of a Club affiliated to a National Association or is not a registered member of the TRA. Any additional entry fees collected are payable to the Licensing Authority within one month of the date of the competition and must be accompanied by copies of the full entry list and results, if requested.
- (iii) As indicated in (ii) above, members of the TRA are not liable to pay the Additional Unattached Entry Fee imposed on Trail races. This applies whether or not the TRA granted a race licence for the race in question.

**RULE 2 REGULATIONS GOVERNING THE CONDUCT OF INTERNATIONAL COMPETITIONS**

1. The Council may produce Regulations governing the conduct of International Competitions held under the Rules and regulating the relationships of athletes, athletes’ representatives, meeting organisers and Members. These Regulations may be varied or amended by the Council as it sees fit.
2. World Athletics and Area Associations may designate one or more representatives to attend every International Competition requiring a World Athletics or Area Association Permit respectively to ensure that the applicable Rules and Regulations are complied with. At the request of the World Athletics or Area Association respectively, such representative(s) shall render a compliance report within 30 days of the end of the International Competition in question.

## SECTION II – COMPETITION OFFICIALS

### RULE 3 INTERNATIONAL OFFICIALS

1. At competitions organised under paragraphs 1.1, 1.2, 1.3 and 1.6 of the International Competition definition, the following officials should be appointed internationally:
  1. Organisational Delegate(s)
  2. Technical Delegate(s)
  3. Medical Delegate
  4. Anti-Doping Delegate
  5. International Technical Officials
  6. International Race Walking Judges
  7. International Road Course Measurer
  8. International Starter
  9. International Photo Finish Judge
  10. Jury of Appeal

The number of officials appointed in each category, how, when and by whom they shall be appointed, shall be indicated in the applicable World Athletics (or Area Association) Technical Regulations.

For competitions organised under paragraphs 1.1. and 1.5 of the International Competition definition, Council may appoint an Advertising Commissioner. For competitions under paragraphs 1.3, 1.6 and 1.10 of the International Competition definition, any such appointments will be made by the relevant Area Association, for competitions under paragraph 1.2 of the International Competition definition, by the relevant body, and for competitions under paragraphs 1.4, 1.8 and 1.9 of the International Competition definition, by the relevant Member.

*Note (i): The International Officials should wear distinctive attire or insignia.*

*Note (ii): The international officials in paragraphs 1.5 to 1.9 of the International Competition definition may be classified as World Athletics Level and Area Level according to the applicable World Athletics Policy.*

The travelling and accommodation expenses of each individual appointed by World Athletics or an Area Association under this Rule or under Rule 3.2 shall be paid to the individual according to the relevant regulations.

#### **RULE 4 ORGANISATIONAL DELEGATES**

The Organisational Delegates shall maintain close liaison with the Organisers at all times and report regularly to the Council (or Area Association or other relevant governing body), and they shall deal as necessary with matters concerning the duties and financial responsibilities of the Organising Member and the Organisers. They shall cooperate with the Technical Delegate(s).

#### **RULE 5 TECHNICAL DELEGATES**

1. The Technical Delegate(s), in conjunction with the Organisers, which shall afford them all necessary help, are responsible for ensuring that all technical arrangements are in complete conformity with the Technical Rules and the World Athletics Track and Field Facilities Manual.

Technical Delegates appointed for competitions other than one day meetings shall:

- 1.1 ensure the submission to the appropriate body of proposals for the timetable of events and the entry standards.
- 1.2 approve the list of implements to be used and whether athletes may use their own implements or those provided by a supplier.
- 1.3 ensure that the applicable Technical Regulations are issued to all competing Members in good time before the competition.
- 1.4 be responsible for all other technical preparations necessary for the holding of the athletics event.
- 1.5 control the entries and have the right to reject them for technical reasons or in accordance with the Rule 8.1 of the Technical Rules (rejection for reasons other than technical must result from a ruling of World Athletics or appropriate Area Association or other relevant governing body.)



- 1.6 determine the qualifying standards for the Field Events, and the basis on which the rounds shall be arranged for Track Events.
- 1.7 cause the seeding and draws for all events to be made in accordance with the Rules and any applicable Technical Regulations and approve all start lists.
- 1.8 decide upon any matters which arise prior to the competition, and for which provision has not been made in these Rules (or any applicable regulations) or the arrangements for the competitions, where appropriate, in conjunction with the organisers.
- 1.9 decide (including where appropriate in conjunction, when available, with the relevant Referee(s) and the Competition Director) upon any matters which arise during the competition and for which provision has not been made in these Rules (or any applicable regulations) or the arrangements for the competitions or which might require a deviation from them in order for the competition to continue in whole or in part or in order to ensure fairness to those taking part.
- 1.10 if requested, chair the Technical Meeting and brief the Technical Officials.
- 1.11 ensure the submission of written reports in advance of the competition on its preparations and after its conclusion on the execution, including recommendations for future editions.

Technical Delegates appointed for one day meetings shall provide all necessary support and advice to the organisers and ensure the submission of written reports on the execution of the competition.

Specific information is provided in the Technical Delegates Guidelines which may be downloaded from the World Athletics website.

Rule 5 of the Competition Rules (and in a similar way Rule 6 of the Competition Rules) has been elaborated to better reflect the current practice in relation to the roles and duties of the respective delegates and international officials. These are intended to make clearer the powers that Technical and Medical Delegates (or persons delegated by them) have in

relation to the conduct of competition, especially in relation to unforeseen events and, perhaps most importantly, when athlete medical care issues arise, particularly in out-of-stadium competitions. However, all matters under the Rules which are within the responsibilities and power of the Referee remain that way. These enhancements to the Rules should not be seen as changing this situation – they are to cover the situations which are not expressly provided for.

## **RULE 6 MEDICAL DELEGATE**

1. The Medical Delegate shall:
  - 1.1 have ultimate authority on all medical matters.
  - 1.2 ensure that adequate facilities for medical examination, treatment and emergency care will be available at the venue(s) of the competition, training and Warm-up areas and that medical attention can be provided where athletes are accommodated and for provision of Rule 6.2 of the Technical Rules.
  - 1.3 make examinations and provide medical certificates in accordance with Rule 4.4 of the Technical Rules.
  - 1.4 have the power to order an athlete to withdraw before, or to immediately retire from an event during, competition.

*Note (i): The powers under Rules 6.1.3 and 6.1.4 of the Competition Rules may be passed by the Medical Delegate to (or where no Medical Delegate is appointed or available be exercised by) one or more medical doctors appointed and so designated by the Organisers who should normally be identified by an armband, vest or similar distinctive apparel. Where the Medical Delegate or doctor is not immediately available to the athlete, they may instruct or direct an official or other authorised person to act on their behalf*

*Note (ii): Any athlete withdrawn or retired from a Running or Race Walking event under Rule 6.1.4 of the Competition Rules shall be shown in the result as DNS and DNF respectively. Any athlete not complying with such an order shall be disqualified from that event.*

*Note (iii): Any athlete withdrawn or retired from a Field Event under Rule 6.1.4 shall be shown in the result as DNS if he has not taken any trial. However, if he has taken any trials, the results of those trials shall stand and the athlete classified in the result accordingly. Any athlete not complying with such an order shall be disqualified from further participation in that event.*

*Note (iv): Any athlete withdrawn or retired from a Combined Event under Rule 6.1.4 shall be shown in the result as DNS if he has not attempted to start the first event. However, if he has attempted to start the first event, Rule 39.10 of the Technical Rules shall apply. Any athlete not complying with such an order shall be disqualified from further participation in that event.*

The health and safety of all participants in the competition is a high priority consideration for World Athletics, other governing bodies and competition organisers. The availability of the expertise of a well-respected and qualified person in the role of Medical Delegate is essential to carry out these key tasks, especially as they (or those authorised by them or the Organisers) amongst other duties has the responsibility to withdraw an athlete from competition if deemed necessary for medical reasons. It is important to note that the power of the Medical Delegate (or a medical doctor acting at their request or in their place) applies to all events.

It is essential that there is a reliable communication system and procedures in place between the Medical Delegate (and those authorised to act in their place), the Technical Delegates and the Competition Director particularly in relation to the duties under Rules 6.1.3 and 6.1.4 of the Competition Rules as these have a direct impact on start lists, results and the management of the competition.

## **RULE 7 ANTI-DOPING DELEGATE**

The Anti-Doping Delegate shall liaise with the Organisers to ensure that suitable facilities are provided for the conduct of doping control. He shall be responsible for all matters relating to doping control.

## **RULE 8 INTERNATIONAL TECHNICAL OFFICIALS (ITOS)**

1. Where ITOs are appointed, the Technical Delegates shall appoint the Chief ITO among the appointed ITOs, if one was not appointed previously by the relevant body. Whenever possible, the Chief ITO, in conjunction with the Technical Delegates, shall assign at least one ITO for every event on the programme. The ITO shall be the Referee of each event to which they are assigned.
2. In Cross-Country, Road Running, Mountain Running and Trail Running competitions, ITOs, if appointed, shall provide all necessary support to the Organisers. They must be present at all times when an event to which they have been assigned is in progress. They should ensure that the conduct of the competition is in full conformity with the Rules, applicable Technical Regulations and relevant decisions made by the Technical Delegates. The ITO shall be the Referee of each event to which they are assigned.

Specific information is provided in the ITO Guidelines which may be downloaded from the World Athletics website.

## **RULE 9 INTERNATIONAL RACE WALKING JUDGES (IRWJS)**

Race Walking Judges appointed for all International Competitions falling under paragraph 1.1 of the International Competition definition must be World Athletics Level International Race Walking Judges.

*Note: Race Walking Judges appointed for competitions paragraphs 1.2, 1.3, 1.5, 1.6, 1.7 and 1.10 of the International Competition definition shall be either World Athletics Level or Area Level International Race Walking Judges.*

## **RULE 10 INTERNATIONAL ROAD COURSE MEASURERS**

At all International Competitions, an International Road Course Measurer shall be appointed to verify the courses where Road Events are held entirely or partially outside the stadium.

The measurer shall be a member of the World Athletics/AIMS Panel of International Road Course Measurers (Grade "A" or "B").

The course should be measured in good time before the competition. The measurer will check and certify the course if they find it conforms to

the Rules for Road Races (See Rules 55.2, 55.3 and 54.11 of the Technical Rules and respective Notes). They shall also ensure compliance with Rules 31.20 and 31.21 of the Competition Rules in case a World Record may be made.

They shall cooperate with the Organisers in the course arrangements and witness the conduct of the race to ensure that the course run by athletes follows the same course that was measured and approved. They shall furnish an appropriate certificate to the Technical Delegate(s).

### **RULE 11 INTERNATIONAL STARTERS AND INTERNATIONAL PHOTO FINISH JUDGES**

At all competitions under paragraphs 1.1, 1.2, 1.3 and 1.6 of the International Competition definition held in the stadium, an International Starter and an International Photo Finish Judge shall be appointed respectively by Council, the relevant Area Association or governing body. The International Starter shall start the races (and undertake any other duties) assigned to them by the Technical Delegate(s) and shall supervise the checking and operation of the Start Information System. The International Photo Finish Judge shall supervise all Photo Finish functions and shall be the Chief Photo Finish Judge.

Specific information is provided in the Starting Guidelines and Photo Finish Guidelines, which may be downloaded from the World Athletics website.

It is noted that whilst the International Photo Finish Judge acts as the Chief Photo Finish Judge at those competitions to which they are appointed and the ITOs act as Referees, there remains a clear division in responsibilities between the International Starter (IS) and the other members of the start team. Whilst the IS takes on all the powers and duties of the Starter when starting any race to which they are allocated, they do not either then or at any other time replace or have the power to override the Start Referee.

**RULE 12 JURY OF APPEAL**

At all competitions organised under paragraphs 1.1, 1.2, 1.3 and 1.6 of the International Competition definition, a Jury of Appeal, which should normally consist of three, five or seven persons shall be appointed. One of its members shall be the Chairman and another the Secretary. If and when considered as appropriate, the Secretary may be a person not included in the Jury.

In instances where there is an appeal relating to Rule 54 of the Technical Rules, at least one member of the Jury of Appeal shall be a World Athletics (or Area) Level International Race Walking Judge.

Members of the Jury of Appeal shall not be present during any deliberations of the Jury concerning any Appeal that affects, directly or indirectly, an athlete affiliated to their own Member Federation. The chair of the Jury shall ask any member implicated by this Rule to withdraw, in the event the Jury member has not already done so. The Council or the relevant governing body shall appoint one or more alternate Jury members to substitute for any Jury member(s) who are not able to participate in an Appeal.

Furthermore, a Jury of Appeal should likewise be appointed at other competitions where the organisers deem it desirable or necessary in the interest of the proper conduct of the competitions.

The primary functions of the Jury of Appeal shall be to deal with all appeals under Rule 8 of the Technical Rules, and with any matters arising during the course of the competition which are referred to it for decision.

**RULE 13 OFFICIALS OF THE COMPETITION**

The Organisers of a competition and/or the relevant governing body shall appoint all officials, subject to the Rules of the Member in whose Country the competition is held and, in the case of competitions under paragraphs 1.1, 1.2, 1.3 and 1.6 of the International Competition definition, subject to the Rules and procedures of the relevant governing body.

The following list comprises the officials considered necessary for major International Competitions. The Organisers may, however, vary this according to local circumstances.

**MANAGEMENT OFFICIALS**

- Competition Director (see Rule 14 of the Competition Rules)

- Meeting Manager and an adequate number of assistants (see Rule 15 of the Competition Rules)
- Technical Manager and an adequate number of assistants (see Rule 16 of the Competition Rules)
- Event Presentation Manager (see Rule 17 of the Competition Rules)

## **COMPETITION OFFICIALS**

- Call Room Referee(s)
- Track Events Referee(s)
- Field Events Referee(s)
- Combined Events Referee(s)
- Referee(s) for events outside the stadium
- Video Referee(s)
- Chief Judge and an adequate number of Judges for Track Events (see Rule 19 of the Competition Rules)
- Chief Judge and an adequate number of Judges for each Field Event (see Rule 19 of the Competition Rules)
- Chief Judge, an adequate number of assistants and five Judges for each Track Race Walking Event (see Rule 54 of the Technical Rules)
- Chief Judge, an adequate number of assistants and eight Judges for each Road Race Walking Event (see Rule 54 of the Technical Rules)
- Other Race Walking Competition officials, as necessary, including Recorders, Posting Board operators, etc. (see Rule 54 of the Technical Rules)
- Chief Umpire and an adequate number of Umpires (see Rule 20 of the Competition Rules)
- Chief Timekeeper and an adequate number of Timekeepers (see Rule 21 of the Competition Rules)
- Chief Photo Finish Judge and an adequate number of assistants (see Rule 21 of these Rules and Rule 19 of the Technical Rules)
- Chief Transponder Timing Judge and an adequate number of assistants (see Rule 21 of these Rules and Rule 19 of the Technical Rules)
- Start Coordinator and an adequate number of Starters and Recalls (see Rule 22 of the Competition Rules)

- Starter's Assistants (see Rule 23 of the Competition Rules)
- Chief Lap Scorer and an adequate number of Lap Scorers (see Rule 24 of the Competition Rules)
- Competition Secretary and an adequate number of assistants (see Rule 25 of the Competition Rules)
- Technical Information Centre (TIC) Manager and an adequate number of assistants (see Rule 25.5 of the Competition Rules)
- Chief Marshal and an adequate number of Marshals (see Rule 26 of the Competition Rules)
- Wind Gauge Operators (see Rule 27 of the Competition Rules)
- Chief Measurement Judge (Scientific) and an adequate number of assistants (see Rule 28 of the Competition Rules)
- Chief Call Room Judge and an adequate number of Call Room Judges (see Rule 29 of the Competition Rules)
- Advertising Commissioner (see Rule 30 of the Competition Rules)

Refer to UKA website at <https://www.uka.org.uk/competitions/rules/> for the descriptions of UKA Technical Officials and Management.

#### **ADDITIONAL OFFICIALS**

- Announcers
- Statisticians
- Doctors
- Stewards for Athletes, Officials and Media

Referees and Chief Judges should wear a distinctive attire or insignia. If deemed necessary, assistants may be appointed. Care should be taken to keep the Field of Play as free from officials and other persons as possible. The number of officials appointed to a competition should be adequate to ensure the required duties are carried out both correctly and efficiently and also to ensure sufficient rest if the competition is over a long period of time on a single day or on several consecutive days. But care must also be taken not to appoint too many so that the competition area becomes cluttered or obstructed by unnecessary personnel. In more and more competitions, some tasks undertaken by on-field officials are being “replaced” by technology and unless a back-up is logically required, this needs to be taken into account when officials are appointed.



### A Note on Safety

Referees and competition officials at athletics events have many important functions, but none is more important than their roles in ensuring the safety of all concerned. The athletics arena can be a dangerous place. Heavy and sharp implements are thrown and pose a hazard to anyone in their path. Athletes running on the track or on runways at high speeds can hurt themselves and anyone with whom they collide. Those competing in jumping events often land in an unexpected or unintended manner. Weather and other conditions can make athletic competition unsafe either temporarily or for longer periods. There have been instances of athletes, officials, photographers and others who have been injured (sometimes fatally) in accidents in or near competition and training areas. Many of those injuries could have been prevented.

Officials must always be mindful of the dangers that are inherent in the sport. They must be alert at all times, and must not allow themselves to be distracted. Regardless of their official position, all officials have the responsibility to do what they can to make the athletics arena a safer place. All officials should think about safety whenever and wherever they are in the competition area, and should intervene when necessary to prevent an accident, when they see conditions or a situation that could lead to one. Ensuring safety is of the utmost importance – even more so than strict compliance with the Rules of competition. In the rare event when there is a conflict, the concern for safety must prevail.

### **RULE 14 COMPETITION DIRECTOR**

The Competition Director shall plan the technical organisation of a competition in cooperation with the Technical Delegate(s), where applicable, ensure that this plan is accomplished and resolve any technical problems together with the Technical Delegate(s).

They shall direct the interaction between the participants in the competition and, through the communication system, shall be in contact with all key officials.

**RULE 15 MEETING MANAGER**

The Meeting Manager shall be responsible for the correct conduct of the Competition. They shall check that all officials have reported for duty, appoint substitutes when necessary and have authority to remove from duty any official who is not abiding by the Rules. In cooperation with the appointed Marshal, they shall arrange that only authorised persons are allowed in the centre of the Field of Play.

*Note: For competitions of longer than four hours or over more than one day, it is recommended that the Meeting Manager has an adequate number of Assistant Meeting Managers.*

The Meeting Manager(s) must be responsible, under the authority of the Competition Director, and in accordance with the Technical Delegates' guidance and decisions, for everything happening in the Field of Play. In the stadium, they must place themselves so as to be able to see everything that is happening and to give necessary orders. They must have in their possession the complete list of all appointed officials and be able to communicate efficiently with the other Managers, Referees and Chief Judges.

In competitions that take place over multiple days in particular it is possible that some judges may not be able to officiate during the whole competition. The Meeting Manager shall have at their disposal a reserve of officials from which they can draw any replacement, if necessary. Even if all the officials for an event are present, the Meeting Manager should ensure that the officials fulfil their duties correctly and if they do not be ready to replace them.

They shall ensure that the Judges (and those assisting them) leave the arena as soon as their event is finished or when their subsequent work is done.

**RULE 16 TECHNICAL MANAGER**

1. The Technical Manager shall be responsible for ensuring that:
  - 1.1 the track, runways, circles, arcs, sectors, landing areas for Field Events and all equipment and implements are in accordance with the Rules;
  - 1.2 the placement and removal of equipment and implements according to the technical organisational plan for the competition as approved by the Technical Delegate(s);
  - 1.3 the technical presentation of the competition areas is in accordance with such plan;
  - 1.4 the checking and marking of any personal implements permitted for the competition is according to Rule 32.2 of the Technical Rules; and
  - 1.5 they have received, or is aware of the existence of, the necessary certification under Rule 10.1 of the Technical Rules before the competition.

The Technical Manager acts under the authority of the Competition Director or the Meeting Manager but an experienced Technical Manager will undertake much of their role without any direction or supervision. They must be contactable at any time. If a Referee or a Field Event Chief Judge notices that the site where an event is taking place (or will take place) needs to be modified or improved, they must refer it to the Meeting Manager who will ask the Technical Manager to take the necessary action. Also, when a Referee feels that there is a need for a change of place of a competition (Rule 25.20 of the Technical Rules) they will act the same way through Meeting Manager who will request the Technical Manager to carry out, or have carried out, the wishes of the Referee. It must be remembered that neither the wind strength nor its change of direction is sufficient condition to change the place of the competition. Once the Competition Director, or for international competitions the Technical Delegates, has approved the implements list to be used during the events, the Technical Manager shall prepare, order and receive the various implements. For the latter, they or their team must then carefully check their weight and dimensions, and any personal implements that are

permitted and submitted, in order to comply with the Rules. They must also ensure that Rule 31.17.4 of the Competition Rules is followed in both a correct and efficient manner if a Record is set.

In relation to throwing implements, the information for manufacturers as to the range of equipment to be supplied to Organisers was removed from the Rules in 2017 and transferred to the documentation relating to the World Athletics certification system. Technical Managers should however apply these guidelines when accepting new equipment from suppliers but should not reject implements submitted for or used in competition because they do not comply with this range. It is the minimum weight that is critical in this regard.

### **RULE 17 EVENT PRESENTATION MANAGER**

The Event Presentation Manager shall plan, in conjunction with the Competition Director, the event presentation arrangements for the competition, in cooperation with the Organisational and Technical Delegate(s), as and where applicable. They shall ensure that the plan is accomplished, resolving any relevant problems together with the Competition Director and the relevant Delegate(s). They shall also direct the interaction between the members of the event presentation team, using the communication system to be in contact with each of them.

They shall ensure that, through announcements and the available technology, the public is informed of information concerning the athletes taking part in each event, including the start lists, intermediate and final results. The official result (placings, times, heights, distances and points) of each event should be conveyed at the earliest practicable moment after receipt of the information.

At competitions held under paragraph 1.1 of the International Competition definition, the English and French language Announcers shall be appointed by Council.

The Event Presentation Manager (EPM) not only has the responsibility of planning, leading and coordinating a production in presentation terms of all the activities that take place on the infield but also integrating them into the show to be presented to the spectators within the venue. The final

aim of their work is to create an informative, entertaining, lively and attractive production of the show that is to be offered to the spectators. To succeed in this it is important to have a team and the necessary equipment to carry out the work. The EPM is the person in charge of coordinating the activities of the event presentation staff working on and off the field who are related to this role including but not limited to the Announcers, Scoreboard and Videoboard Operators, Audio and Video Technicians and Victory Ceremony officials.

For almost every competition, an announcer is essential. They must be placed so as to be able to follow the meeting properly and preferably near to or otherwise in immediate communication with the Competition Director or if appointed, the Event Presentation Manager.

### **RULE 18 REFEREES**

1. One (or more) Referee(s), as appropriate, shall be appointed for the Call Room, for Track Events, for Field Events, for Combined Events and for Running and Race Walking Events outside the stadium. When appropriate, one (or more) Video Referee(s) shall also be appointed. A Referee appointed to oversee the starts is designated the Start Referee.

The Video Referee(s) shall operate from a Video Review Room, should consult and shall be in communication with the other Referees.

At meetings where sufficient officials are available so that more than one Referee is appointed for the races, it is strongly recommended that one of them is appointed as the Start Referee. To be clear the Start Referee in such circumstances should exercise all the powers of the Referee in relation to the start and is not required to report to or act through any other track Referee when doing so.

However, if only one Referee is appointed to oversee the races of a certain competition, and considering the powers they have, it is strongly recommended that the Referee be positioned in the start area, during each start (at least for those events using a crouch start) to witness any eventual problem that may occur and to take any decision needed to solve it. This

will be easier when a World Athletics certified start information system is in use.

If not, and if the Referee will not have time to place themselves in line with the finish line after the start procedure (as in 100m, 100/110m hurdles and 200m), and foreseeing the possible need for the Referee to decide placings, a good solution may be to have the Start Coordinator (who should have an extensive experience as a starter) being appointed to also act as Start Referee.

2. Referees shall ensure that the Rules and Regulations (and other regulations for each particular competition) are observed. They shall rule on any protest or objection regarding the conduct of the competition and shall decide upon any matters which arise during the competition (including in the Warm-up Area, Call Room and, after the competition, up to and including the Victory Ceremony) and for which provision has not been made in these Rules (or any applicable regulations), where appropriate or necessary in conjunction with the Technical Delegates.

The Referee shall not act as a Judge or Umpire but may take any action or decision according to the Rules based on their own observations and may overrule a decision of a Judge.

*Note: For the purpose of this Rule and applicable regulations, including the Advertising Regulations, the Victory Ceremony is concluded when all directly related activities (including photographs, victory laps, crowd interaction, etc.) are completed.*

It should be carefully noted that it is not necessary for a Referee to have received a report from a Judge or Umpire in order to make a disqualification. They may act at all times by their own direct observation.

The above Note should be interpreted to include all matters which are incidental to or relate to the Victory Ceremony and that the Referee for that event is responsible for them. When Victory Ceremonies are held at a different location or in a different session, common sense should be applied and if necessary another Referee may have to be substituted if it is not practical for the original Referee to manage the situation. See also commentary after Rule 5 of the Competition Rules.

3. The Referees for Track Events and for events outside the stadium shall have jurisdiction to decide placings in a race only when the Judges of the disputed place(s) are unable to arrive at a decision. They shall have no jurisdiction over matters within the responsibilities of the Chief Judge of Race Walking events. The relevant Track Referee has jurisdiction to decide on any facts related to the starts if they do not agree with the decisions made by the start team except in the cases when it regards an apparent false start indicated by a World Athletics certified Start Information System, unless for any reason the Referee determines that the information provided by the System is obviously inaccurate. The Combined Events Referee shall have jurisdiction over the conduct of the Combined Events competition and over the conduct of the respective individual events within it (except in matters related to their jurisdiction when a Start Referee is appointed and available).
4. The appropriate Referee shall check all final results, shall deal with any disputed points and, in conjunction with the Chief Measurement Judge (Scientific) where appointed, shall supervise the measurements of Record performances. At the conclusion of each event, the result card shall be completed immediately, signed (or otherwise approved) by the appropriate Referee and conveyed to the Competition Secretary.
5. The applicable Referee shall have authority to warn or exclude from competition, any athlete or relay team guilty of acting in an unsporting or improper manner or under Rules 6, 16.5, 17.14, 17.15.4, 25.5, 25.19, 54.7.4, 54.10.8 or 55.8.8 of the Technical Rules. Warnings may be indicated to the athlete by showing a yellow card, exclusion by showing a red card. Warnings and exclusions shall be entered on the result card and communicated to the Competition Secretary and to the other Referees. In disciplinary matters, the Call Room Referee has authority starting from the Warm-up Area up to the competition area. In all other instances, the Referee applicable to the event in which the athlete is or was competing, shall have authority. The applicable Referee (where practicable after consulting the Competition Director) may warn or remove any other person from the competition area (or other area related to the competition including the Warm-up Area, Call Room and coaches seating) who

is acting in an unsporting or improper manner or who is providing assistance to athletes that is not permitted by the Rules.

*Note (i): The Referee may, where the circumstances justify it, exclude an athlete or relay team without a warning having been given. (See also Note to Rule 6.2 of the Technical Rules)*

*Note: (ii): The Referee for events outside the stadium shall, wherever practicable (e.g. under Rules 6, 54.10 or 55.8 of the Technical Rules), give a warning prior to disqualification. If the Referee's action is contested, Rule 8 of the Technical Rules will apply.*

*Note (iii): When excluding an athlete or relay team from competition under this Rule, if the Referee is aware that a yellow card has already been given, they should show a second yellow card followed immediately by a red card.*

*Note (iv): If a yellow card is given and the Referee is not aware that there is a previous yellow card, it shall, once this is known, have the same consequence as if it was given in association with a red card. The relevant Referee shall take immediate action to inform the athlete or relay team or their team of their exclusion.*

*UKA Supplementary Note: Spitting (or similar) in warm up, call room, field of play or any other public area may be treated as a conduct offence and will be dealt with by a warning or disqualification (yellow card and / or red card offence).*

The below key points are made to provide guidance and clarity in relation to the way in which cards are shown and recorded:

- (1) Yellow and red cards can be given either for disciplinary reasons (refer mostly to Rule 18.5 of the Competition Rules and Rule 7.2 of the Technical Rules) or for technical infringements.
- (2) Whilst it is normal and usually expected that a yellow card would have been given before a red card, it is envisaged that in the cases of particularly bad unsporting or improper behaviour a red card can be given immediately. It should be noted that the athlete or relay team has in any case the opportunity to appeal such a decision to the Jury of Appeal.
- (3) There will be also some cases in which it is not practical or even logical for a yellow card to have been issued. For example the note to Rule 6.2 of the Technical Rules specifically allows for an immediate red card if justified in cases covered by Rule 6.3.1 of the Technical Rules



such as pacing in races.

(4) A similar situation might also follow when a Referee issues a yellow card and the athlete or relay team responds in such an inappropriate manner that it is justified to then immediately give a red card. It is not essential for there to be two completely different and distinct in time instances of inappropriate behaviour.

(5) As per Note (iii), in cases where a Referee is aware that the athlete or relay team in question has already received a yellow card during the competition and they propose to issue a red card, the Referee should first show a second yellow card and then the red card. However if a referee does not show the second yellow card, it will not invalidate the issuing of the red card.

(6) In cases where a Referee is not aware of a pre-existing yellow card, and he shows only a yellow card, once this becomes known, the appropriate steps should be taken to disqualify the athlete as soon as possible. Normally, this would be done by the Referee advising the athlete directly or through his team.

(7) In cases of relay events, cards received by one or more members of the team during any round of the event shall count against the team. Therefore, if one athlete receives two cards or two different athletes receive a yellow card in any round of the particular event, the team shall be regarded as having received a red card and shall be disqualified. Cards received in relay events are only applicable to the team and never applicable to an individual athlete.

6. The Referee may reconsider a decision (whether made in the first instance or in considering a protest) on the basis of any available evidence, provided the new decision is still applicable. Normally, such re-consideration may be undertaken only prior to the Victory Ceremony for the relevant event or any applicable decision by the Jury of Appeal.

This Rule clarifies that as with the Jury of Appeal (see Rule 8.9 of the Technical Rules) a Referee can reconsider a decision and may do so equally whether this was a decision by themselves in the first instance or one made when considering a protest made to them. This option can be considered especially when new evidence of information comes to hand quickly as it could avoid the need for a more complicated or involved appeal to the Jury of Appeal. But note the

7. If, in the opinion of the appropriate Referee, circumstances arise at any competition such that justice demands that any event or any part of an event should be contested again, they shall have authority to declare the event or any part of an event void and that it shall be held again, either on the same day or on some future occasion, as they shall decide. (See also Rules 8.4 and 17.2 of the Technical Rules).

It should be carefully noted by Referees and Juries of Appeal that, except in very special circumstances, an athlete who does not finish a race, should not be advanced to a later round or included in a re-run of an event.

8. Where an athlete with a physical disability is competing in a competition under these Rules, the appropriate Referee may interpret, or allow a variation from, any relevant Rule (other than Rule 6.3) to enable the participation of the athlete provided that such variation does not provide the athlete with any advantage over another athlete competing in the same event. In the case of any doubt or if the decision is disputed, the matter shall be referred to the Jury of Appeal.

*Note: This Rule is not intended to permit the participation of guide runners for visually impaired athletes, unless allowed by the regulations of a particular competition.*

This Rule facilitates the participation of ambulant athletes with a disability to compete in athletic competitions with able-bodied athletes. For example, an arm amputee is not able to strictly comply with Rule 16.3 of the Technical Rules during a crouch start by putting both hands on the ground. This Rule enables a Start Referee to interpret the Rules in such a way to allow the athlete to place their stump on the ground, or to place wooden blocks or the like on the ground behind the start line on which an arm stump is placed, or in the case of a high upper arm amputee who is not able to make contact with the ground in any way, to adopt a start position without any contact with the ground.

It should be noted however that this Rule does not allow the use of guide runners in able bodied competitions (unless specifically allowed by the regulations for the particular competition) nor does it allow Referees to interpret the Rules in such a way that the relevant aspects of Rule 6 of the

Technical Rules are infringed – particularly the use of technologies or appliances which would give the wearer an advantage [see Rules 6.3.3 and 6.3.4 of the Technical Rules which covers specifically the use of prostheses and other aids].

In cases where athletes with a disability are competing in the same event at the same time as able-bodied athletes and they are not compliant with the Rules (either because the Rules so specifically provide or the Referee is not able to interpret the Rules sufficiently in accordance with Rule 18.8 of the Competition Rules) then a separate result should be declared for those athletes or their participation otherwise clearly indicated in the results. (See also Rule 25.3 of the Competition Rules). Regardless it is always useful to indicate, in entry and start lists and in results, the IPC classification for any para-athlete who is participating.

## **RULE 19 JUDGES**

### **GENERAL**

1. The Chief Judge for Track Events and the Chief Judge for each Field Event shall co-ordinate the work of the Judges in their respective events. When the Organisers have not already allocated the duties of the Judges, they shall allocate the duties.
2. The Judges may reconsider any original decision made by them if it was made in error, provided the new decision is still applicable. Alternatively, or if a decision has subsequently been made by a Referee or the Jury of Appeal, they shall refer all available information to the Referee or to the Jury of Appeal.

### **TRACK EVENTS AND ROAD EVENTS**

3. The Judges, who must all operate from the same side of the track or course, shall decide the order in which the athletes have finished and, in any case where they cannot arrive at a decision, shall refer the matter to the Referee, who shall decide.

*Note: The Judges should be placed at least 5m from, and in line with, the finish and should be provided with an elevated platform.*

**FIELD EVENTS**

4. The Judges shall judge and record each trial and measure each valid trial of athletes in all Field Events. In the High Jump and Pole Vault, precise measurements should be made when the bar is raised, particularly if Records are being attempted. At least two Judges should keep a record of all trials, checking their recordings at the end of each round of trials.

The appropriate Judge shall indicate the validity or non-validity of a trial by raising a white or red flag, as appropriate.

Unless a Judge is sure that an infringement of the Rules has occurred they will normally give the benefit of any doubt to the athlete, determine that the trial is valid and raise a white flag. However when a Video Referee is appointed and with access to footage for the Field Events, there is an option in the case of some doubt for the Judge in conjunction with the on-field Referee to delay the raising of either flag until they have sought the advice of the Video Referee - always ensuring either that the landing mark is preserved or the trial is measured in case it is valid. Alternatively, the Judge, if in real doubt, could raise the red flag, ensure the mark is preserved or that the trial is measured, and then seek advice from the Video Referee.

It is recommended that for each Field Event only one set of white and red flags is used in order to reduce the possibility of any confusion about the validity of trials. It is considered that it is never necessary to use more than one set of flags in a jumping event. Where a specific scoreboard is not available to indicate the wind reading in Horizontal Jumps, some form of indication other than a red flag should be used to indicate an excessive reading.

In the case of throwing events, with respect to:

- (a) indications by other circle Judges to the Judge with the flags that a failure has been made, it is recommended that an alternate form of indication to flags is used such as a small red card held in that Judge's hand;
- (b) the landing of an implement on or outside the sector line, it is recommended that an alternate form of indication to a flag is used - such as a Judge's outstretched arm parallel to the ground;
- (c) a judgment in the javelin throw that the metal head has not touched the ground before any other part of the javelin, it is recommended that an

alternate form of indication to a flag is used - such as the pushing of the open hand of the Judge towards the ground.

## **RULE 20 UMPIRES (RUNNING AND RACE WALKING EVENTS)**

1. Umpires are assistants to the Referee, without authority to make final decisions.
2. The Umpires shall be placed by the Referee in such a position that they may observe the competition closely and, in the case of a failure or violation of the Rules (other than Rule 54.2 of the Technical Rules) by an athlete or other person, make an immediate written report of the incident to the Referee.
3. Any such breach of the Rules should be communicated to the relevant Referee by the raising of a yellow flag or any other reliable means approved by the Technical Delegate(s).
4. A sufficient number of Umpires shall also be appointed to supervise the takeover zones in Relay Races.

*Note (i): When an Umpire observes that an athlete has run in a different lane from their own, or that a relay takeover has taken place outside the takeover zone, they should immediately mark on the track with suitable material the place where the infringement took place or make a similar notation on paper or by electronic means.*

*Note (ii): The Umpire(s) shall report to the Referee any breach of the Rules, even if the athlete (or team, for Relay Races) does not finish the race.*

The Chief Umpire (see Rule 13 of the Competition Rules) is the assistant of the Track Referee and indicates the placement of and co-ordinates the work and reports of each Umpire. Charts which may be downloaded from the World Athletics website recommend the points at which the Umpires (subject always to the number available) should be placed for the various track events. It must be understood that the charts describe one possibility. It is up to the Meeting Manager in consultation with the Track Referee to select the appropriate number of Umpires according to the level of the meeting, the number of entries and the number of available officials.

### Indication of an infringement

When the events take place on a synthetic track, it has been the practice to provide the Umpires with adhesive tape so that they can mark the track where an infringement has taken place – although the Rules (see note (i) above) now acknowledge that this may be and is often done in other ways. Note that the failure to report an infringement in a particular way (or at all) does not prevent a valid disqualification being made.

It is important that Umpires “report” all instances where they believe the Rules have been infringed, even when the athlete or team does not finish the race. The addition of Rule 8.4.4 Of the Technical Rules is intended to standardise practice and to complement Note (ii) to Rule 20.4 of the Competition Rules - as there has been a clear difference of approach across the World.

The standard practice overall should be that where an athlete / relay team does not finish a race, it is generally to be denoted as DNF rather than DQ, including in hurdles races where a technical rule has been breached but the athlete does not reach the finish line. Rule 8.4.4 of the Technical Rules is in place to cover the situation where such an athlete or team makes a protest – so sub-rule 8.4.4 is thus added.

## **RULE 21 TIMEKEEPERS, PHOTO FINISH JUDGES AND TRANSPONDER TIMING JUDGES**

1. In the case of hand timing, a sufficient number of timekeepers for the number of athletes entered shall be appointed. One of them shall be designated the Chief Timekeeper. They shall allocate duties to the Timekeepers. These Timekeepers shall act as back-up Timekeepers when Fully Automatic Photo Finish or Transponder Timing Systems are in use.
2. Timekeepers, Photo Finish and Transponder Timing Judges shall act in accordance with Rule 19 of the Technical Rules.
3. When a Fully Automatic Timing and Photo Finish System is used, a Chief Photo Finish Judge and an adequate number of assistants shall be appointed.
4. When a Transponder Timing System is used, a Chief Transponder Timing Judge and an adequate number of assistants shall be

appointed.

The Guidelines for Manual Timekeeping may be downloaded from the World Athletics website.

## **RULE 22 START COORDINATOR, START AND RECALLERS**

1. The Start Coordinator shall:
  - 1.1. Allocate the duties of the start team. However, in the case of competitions under paragraph 1.1 of the International Competition definition and Area Championships and Games, the determination of which events will be assigned to the International Starter will be the responsibility of the Technical Delegates.
  - 1.2. Supervise the duties to be fulfilled by each member of the team.
  - 1.3. Inform the Starter, after receiving the relevant order from the Competition Director, that everything is in order to initiate the start procedure (e.g. that the Timekeepers, the Judges and, when applicable, the Chief Photo Finish Judge, Chief Transponder Timing Judge and the Wind Gauge Operator are ready).
  - 1.4. Act as an interlocutor between the technical staff of the timing equipment company and the Judges.
  - 1.5. Keep all papers produced during the start procedure including all documents showing the reaction times and/or false start waveform images if available.
  - 1.6. Ensure that following any ruling under Rules 16.8 or 39.10.3 of the Technical Rules, the procedure set out in Rule 16.9 of the Technical Rules is followed.

All members of the start team must be well informed about the Rules and how they should be interpreted. The team must also be clear on what procedures it will follow when implementing the Rules, so that the events can continue without delay. They must understand well the respective duties and roles of each member of the team, especially the Starter and the Start Referee.

2. The Starter, whose primary responsibility is to ensure a fair and equitable start for all competitors, shall have entire control of the athletes on their marks. When a Start Information System is used to assist in races using a crouch start, Rule 16.6 of the Technical Rules shall be applied.
3. The Starter shall position themselves so that they have full visual control over all athletes during the start procedure.  
It is recommended, especially for staggered starts, that loudspeakers in the individual lanes be used for relaying the commands and the start and any recall signals to all athletes at the same time.

*Note: The Starter shall place themselves so that the whole field of athletes falls into a narrow visual angle. For races using a crouch start it is necessary that they are so placed that they can ascertain that all athletes are currently steady in their set positions before the gun is fired or starting apparatus is activated. (All such starting apparatus is termed "gun" for the purpose of the Rules.) Where loudspeakers are not used in races with a staggered start, the Starter shall so place themselves that the distance between them and each of the athletes is approximately the same. Where, however, the Starter cannot place themselves in such a position, the gun shall be placed there and discharged by electric contact.*

The Starter's commands have to be clear and heard by all athletes but, unless they are a long way from the athletes and without a speaker system, they should avoid shouting whilst giving the commands.

4. One or more Recallers shall be assigned to assist the Starter.  
*Note: For events of 200m, 400m, 400m Hurdles, 4 × 100m, 4 × 200m, the Medley Relay and 4 × 400m Relays, there shall be at least two Recallers.*
5. Each Recaller shall place themselves so that they can see each athlete assigned to them.
6. The Starter and/or each Recaller shall recall or abort the race if any infringement of the Rules is observed. After a recalled or aborted start the Recaller shall report their observations to the Starter, who decides whether and to which athlete(s) a warning or disqualification shall be issued. (See also Rules 16.7 and 16.10 of the Technical Rules.)



7. Warning and disqualification under Rules 16.7, 16.8 and 39.10.3 of the Technical Rules may be decided only by the Starter. (See also Rule 18.3 of the Competition Rules)

It is necessary to take into account Rule 18.3 of the Competition Rules when interpreting both this Rule and Rule 16 of the Technical Rules, for in effect it is both the Starter and the Referee responsible for the starts who can determine whether a start is fair. On the other hand a Recaller has no such power and whilst they may recall a start, they cannot act unilaterally thereafter and must simply report their observations to the Starter.

The Starting Guidelines may be downloaded from the World Athletics website.

### **RULE 23 STARTERS ASSISTANTS**

1. The Starter's Assistants shall check that the athletes are competing in the correct heat or race and that their bibs are worn correctly.
2. They must place each athlete in their correct lane or position, assembling the athletes approximately 3m behind the start line (in the case of races started in echelon, similarly behind each start line). When this has been completed, they shall signal to the Starter that all is ready. If a new start is ordered, the Starter's Assistants shall assemble the athletes again.
3. The Starter's Assistants shall be responsible for the readiness of batons for the first athletes in a Relay Race.
4. When the Starter has ordered the athletes to their marks, the Starter's Assistants must ensure that Rules 16.3 and 16.4 of the Technical Rules are observed.
5. In case of a false start, the Starter's Assistants shall proceed in accordance with Rule 16.9 of the Technical Rules.

## **RULE 24 LAP SCORERS**

1. Lap Scorers shall keep a record of the laps completed by all athletes in races longer than 1500m. Specifically, for races of 5000m and longer, and for Race Walking events, a number of Lap Scorers under the direction of the Referee shall be appointed and provided with lap scoring cards on which they shall record the times over each lap (as given to them by an official Timekeeper) of the athletes for whom they are responsible. When such a system is used, no Lap Scorer should record more than four athletes (six for Race Walking events). Instead of manual lap scoring, a computerised system, which may involve a transponder carried or worn by each athlete, may be used.
2. One Lap Scorer shall be responsible for maintaining, at the finish line, a display of the laps remaining. The display shall be changed each lap when the leader enters the finish straight. In addition, manual indication shall be given, when appropriate, to athletes who have been, or are about to be, lapped.  
The final lap shall be signalled to each athlete, usually by ringing a bell.

[Guidelines for Lap Scoring may be downloaded from the World Athletics website.](#)

## **RULE 25 COMPETITION SECRETARY, TECHNICAL INFORMATION CENTRE (TIC)**

1. The Competition Secretary shall collect the full results of each event, details of which shall be provided by the Referee, the Chief Timekeeper, Chief Photo Finish Judge or Chief Transponder Judge and the Wind-Gauge Operator. They shall immediately relay these details to the Announcer, record the results and convey the result card to the Competition Director.  
Where a computerised results system is used, the computer recorder at each Field Event shall ensure that the full results of each event are entered into the computer system. The track results shall be input under the direction of the Chief Photo Finish Judge. The Announcer and the Competition Director shall have access to the results via a computer.

2. In events in which athletes are competing with different specifications (such as implement weights or hurdle heights), the relevant differences should be clearly indicated in the results or a separate result shown for each category.
3. Where the applicable regulations for a competition other than under paragraph 1.1 of the International Competition definition permit the simultaneous participation of athletes:
  - 3.1. competing with the assistance of another person, i.e. a guide runner; or
  - 3.2. using a mechanical aid which is not authorised under Rule 6.3.4 of the Technical Rules;
  - 3.3. their results shall be listed separately and, where applicable, their para classification shown.
4. The following standard abbreviations and symbols should be used in the preparation of start lists and results where applicable:
  - Did not start – DNS
  - Did not finish – DNF (Running or Race Walking Events)
  - No valid trial recorded – NM
  - Disqualified – DQ (followed by the applicable Rule number)
  - Valid trial in High Jump and Pole Vault – “O”
  - Failed trial – “X”
  - Passed trial – “\_”
  - Retired from competition (Field or Combined Events) – r
  - Qualified by place in Track Events – Q
  - Qualified by time in Track Events – q
  - Qualified by standard in Field Events– Q
  - Qualified by performance in Field Events – q
  - Advanced to next round by Referee – qR
  - Advanced to next round by Jury of Appeal – qJ
  - Bent knee (Race Walking Events) – “>”
  - Loss of contact (Race Walking Events) – “~”
  - Yellow Card – YC (followed by the applicable Rule number)
  - Second Yellow Card – YRC (followed by the applicable Rule number)
  - Red Card – RC (followed by the applicable Rule number)

If an athlete is warned or disqualified in an event for an infringement of any Rule, reference shall be made in the official results to the Rule which

has been infringed.

If an athlete is disqualified from an event for acting in an unsporting or improper manner, reference shall be made in the official results giving reasons for such disqualification.

Rules 25.2-4 of the Competition Rules as from 2015 are designed to standardise procedures and the use of terminology in common situations in start lists and results. Rules 25.2 and 25.3 of the Competition Rules acknowledge the not uncommon situation in many competitions below the top level (and even in some high level competitions) where athletes of different age and who have para classifications are competing in the same competitions. This Rule confirms that this is acceptable - including as a means of meeting minimum competitor number requirements, even for the purposes of Rule 31.1 of the Competition Rules as well as setting out how the results should be presented.

Given that disqualifications can be made for both technical and disciplinary reasons, it is very important that the reason for a disqualification is always indicated in the results. This is achieved by always stating the Rule under which the athlete was warned or disqualified next to the symbol.

The use of 'r' is designed to cover situations in which an athlete decides not to continue in a competition because of injury (or any other reason as it is not necessary for him to provide one). Most commonly, this will be in High Jump or Pole Vault and here it is important to note that this has implications for the further conduct of the competition, including the application of time for trials under Rule 25.17 of the Technical Rules, as a retirement may reduce the remaining athletes in the competition to 1 or 2 or 3 and the application of a longer time for trials to be taken.

It is also relevant in Combined Events, as it may affect the number of heats to be conducted in any remaining Track Events.

In other Field Events, an alternate method would be to show all remaining trials as a pass but the use of 'r' provides a clear indication that the athlete is no longer intending to compete in that event – whereas showing passes still leaves the possibility that the athlete could later change his mind.

See also the green text with respect to Rule 6 of the Competition Rules.

5. A Technical Information Centre (TIC) will be established for competitions held under paragraphs 1.1, 1.2, 1.3, 1.6 and 1.7 of the International Competition definition and is recommended for other competitions held over more than one day. The main function of the TIC is to ensure smooth communication between each team delegation, the organisers, the Technical Delegates and the competition administration regarding technical and other matters relating to the competition.

An effectively managed Technical Information Centre will significantly assist in the delivery of a high quality competition organisation. The TIC Manager should have excellent knowledge of the Rules and equally importantly of the specific Regulations for the particular competition.

The hours of operation of the TIC should reflect the hours of the competition plus some periods of time before and after when there will need to be interaction between the various parties, particularly between the team delegations and the Organisers. It is common, although not essential, for larger events to have “branches” of the TIC (sometimes called Sport Information Desks) in the main athlete accommodation locations. If this is the case, there must be excellent communication between the SID(s) and the TIC.

Because the hours of operation of the TIC and SID(s) may be long, it will be necessary for the TIC Manager to have several assistants and for them to work in shifts.

Whilst some duties of the TIC are covered in the Competition Rules (see for example Rule 25 of the Competition Rules, and Rules 8.3 and 8.7 of the Technical Rules), others will be set out in the Regulations for each competition and in competition documents such as team handbooks etc.

## **RULE 26 MARSHAL**

The Marshal shall have control of the Field of Play and shall not allow any persons other than the officials and athletes assembled to compete or other authorised persons with valid accreditation to enter and remain therein.

The Marshal's role is to regulate entry to the Field of Play during preparations immediately beforehand and while the event is in progress. They operate generally in accordance with the plan established by the Competition Director and in relation to more immediate matters receives their orders directly from the Meeting Manager. Accordingly they will:

- (a) manage the control for the entrances into the arena of the athletes, the officials and on-field volunteers, service staff, accredited press photographers and the TV crews. At each competition, the number of such in-field accreditations is agreed beforehand and all these persons must wear a special bib;
- (b) manage the control at the point where the athletes leave the arena (usually for larger events into the Mixed Zone and/or the Post Event Control Area) when they have finished their event;
- (c) ensure that, at all times, the sight lines to the competition sites are as clear as possible for the spectators' benefit as well as for television. They are directly answerable to the Meeting Manager who must be able to contact them at any time if the need arises.

To assist the Marshal and their team in their work it is usual that those persons permitted to enter the arena, other than the athletes, are clearly distinguishable by means of the special bib or accreditation card or distinctive uniform.

## **RULE 27 WIND GAUGE OPERATOR**

The Wind Gauge Operator shall ascertain the velocity of the wind in the running direction in events to which they are appointed and shall then record and sign the results obtained and communicate them to the Competition Secretary.

Whilst in practice it may be that the Wind Gauge Operator, the Technical Manager or a Photo Finish Judge actually puts the gauge in the correct place ultimately it is the responsibility of the relevant Referee to check that this is done and in accordance with the Rules (see Rules 17.10 and 29.11 of the Technical Rules)

It is noted that particularly for the Track Events the wind gauge can be operated remotely. In such cases it is almost always connected to the photo finish and results “system”, so that a Wind Gauge Operator will not be required and their duties are filled, for example, by someone in the photo finish team.

### **RULE 28 MEASUREMENT JUDGE (SCIENTIFIC)**

One Chief Measurement Judge (Scientific) and one or more assistants shall be appointed when Electronic or Video Distance Measurement or other scientific measurement device is to be used.

Before the start of the competition, they will meet the technical staff involved and familiarise themselves with the equipment.

Before each event, they will supervise the positioning of the measuring instruments, taking account of the technical requirements given by the manufacturer and the instrument calibrating laboratory.

To ensure that the equipment is operating correctly, they shall, before the event, supervise a set of measurements in conjunction with the Judges and under the supervision of the Referee, to confirm agreement with results achieved using a calibrated and verified steel tape. A form of conformity shall be issued and signed by all those involved in the test and attached to the results card.

During the competition they shall remain in overall charge of the operation. They will report to the Referee to certify that the equipment is accurate.

*Note: A set of check measurements should be made after, and if circumstances justify it during, the event usually without reference to the steel tape.*

When electronic or video distance measuring equipment is used, a Chief Judge is placed as the official in charge in a similar way as is the case

with photo finish or transponder timing. In the case of video measurement, the Chief Measurement Judge will be expected to take a more active and hands-on role during the events, than would be the case with fully on-field electronic distance measurement.

In particular, this should involve ensuring that an appropriate communication system is in place between the on-field Judges and the Judges undertaking the video reading to ensure that each measurement is correctly made and that in the case of the Horizontal Jumps, the landing mark is not raked out until an image has been confirmed.

Whether it is the Chief Measurement Judge or another Judge who is responsible for ensuring the video reading is correct, they must be especially careful to ensure that the current, and not a previous, trial is the one that is measured.

## **RULE 29 CALL ROOM JUDGES**

1. The Call Room Chief Judge shall:
  - 1.1. in conjunction with the Competition Director, prepare and publish a Call Room schedule setting out for each event at least the first and final entry times for each Call Room in use and the time at which the athletes will depart for the competition area from the (final) Call Room;
  - 1.2. supervise the transit between the Warm-up Area and the competition area to ensure that the athletes, after being checked in the Call Room, be present and ready at the competition area for the scheduled start of their event.

The Call Room Judges shall ensure that athletes are wearing the national or Club uniform clothing officially approved by their national governing body, that the bibs are worn correctly and correspond with start lists, that shoes, number and dimension of spikes, advertising on clothing and athletes' bags comply with the Rules and applicable Regulations and that unauthorised material is not taken into the Field of Play.

The Judges shall refer any unresolved issues or matters arising to the Call Room Referee.

A well planned and efficiently managed Call Room is fundamental to the success of a competition. Planning to ensure sufficient space at the point



when the Call Room will be at its fullest capacity, how many call rooms (and sections within each) are required and a reliable communication system with the other officials and to notify the athletes when to report from the Warm-up Area are always important. Other considerations will vary according to the type of competition and the number of checks which it is decided will be undertaken in the Call Room. For example at most school meets it is unlikely that checking advertising on uniforms will be an issue, whereas checking spike lengths to protect the track surface may be. It is important that in the planning process it is determined which checks will be made and preferably these should be communicated to the athletes and teams in advance to avoid stress or confusion immediately before competition. The Call Room Judges must ensure the athletes are in the correct heat, race or group and that they leave for the competition area in a timely manner in accordance with the Call Room schedule. Where possible, the schedule should be made available to the athletes and teams prior to the commencement of each day of competition.

### **RULE 30 ADVERTISING COMMISSIONER**

The Advertising Commissioner (when appointed) will supervise and apply the current Marketing & Advertising Rules and Regulations and shall determine any unresolved advertising issues or matters arising in the Call Room in conjunction with the Call Room Referee.

## SECTION III – WORLD RECORDS

### RULE 31 WORLD RECORDS

#### SUBMISSION AND RATIFICATION

1. A World Record shall be made in a bona fide competition which has been duly arranged, advertised and authorised before the day of the event by the Member in whose Country or Territory the event takes place and which has been conducted under and in compliance with the Rules. For individual events, at least three athletes and for relay events, at least two teams must be bona fide competitors in the event. Except for Field Events conducted as provided in Rule 9 of the Technical Rules and competitions held outside the stadium under Rules 54 and 55 of the Technical Rules, no performance set by an athlete will be ratified if it has been accomplished during a mixed competition.

*Note: Women only Road Race records are subject to the conditions set out in Rule 32 of the Competition Rules.*

2. The following categories of World Records are accepted by World Athletics:
  - 2.1 World Records;
  - 2.2 World U20 Records;
  - 2.3 World Indoor Records;
  - 2.4 World U20 Indoor Records.

*Note (i): For the purposes of these Rules, unless the context dictates otherwise, World Records refers to all categories of records under this Rule.*

*Note (ii): World Records under Rules 31.2.1 and 31.2.2 of the Competition Rules shall recognise the best ratified performances achieved at any facility complying with Rule 31.12 or 31.13 of the Competition Rules*

3. An athlete (or athletes in the case of a relay event) who sets a World Record must:
  - 3.1. have been eligible to compete under the Rules;
  - 3.2. have been under the jurisdiction of a Member;

- 3.3. in the case of a performance submitted under Rules 31.2.2 or 31.2.4 of the Competition Rules, unless the athlete's date of birth has been previously confirmed by the Chief Executive Officer, have their date of birth confirmed by their passport, birth certificate or similar official documentation, a copy of which, if not available to be attached to the application form, must be provided by the athlete or athletes' Member Federation to the Chief Executive Officer without delay;
- 3.4. in the case of relay events, must all be eligible to represent a single Member in accordance with Eligibility to Represent a Member Rules.
- 3.5. submit to doping control at the end of the event, to be conducted in accordance with the Rules and Anti-Doping Regulations currently in force. The sample(s) collected shall be sent for analysis to a WADA-accredited laboratory and the result(s) sent to the Integrity Unit to be added to the other information required by the Rules and Regulations for ratification. If such testing results in a doping violation, or if such a testing is not conducted, the performance will not be ratified.

*Note (i): In the case of a Relay World Record, all members of the team must be tested;*

*Note (ii): If an athlete has admitted that, at some time prior to achieving a World Record, they had used or taken advantage of a substance or technique prohibited at that time, then, subject to the advice of the Athletics Integrity Unit, such record will not continue to be regarded as a World Record by World Athletics.*

4. When a performance equals or betters an existing World Record, the Member of the Country where the performance was set shall collect together, without delay, all the information required for ratification of the Record by World Athletics. No performance shall be regarded as a World Record until it has been ratified by World Athletics. The Member should immediately inform World Athletics of its intention to submit the performance.

5. The submitted performance shall be better than or equal to the existing World Record for that event, as accepted by World Athletics. If a World Record is equalled it shall have the same status as the existing World Record.
6. The official application form of World Athletics shall be completed and dispatched to the Office within 30 days. If the application concerns a foreign athlete (or a foreign team), a duplicate of the form shall be sent within the same period to the Member of the athlete (or team).

*Note: Forms are available, on request, from the World Athletics Office, or may be downloaded from the World Athletics website.*

7. The Member of the Country where the performance was set shall send, with the official application form:
  - 7.1. The printed programme of the competition (or electronic equivalent);
  - 7.2. The complete results of the event, including all information required under this Rule;
  - 7.3. In the case of a Track World Record where Fully Automatic Timing was in operation, the photo finish and zero control test images;
  - 7.4. Any other information required to be submitted by this Rule, where such information is or should be in its possession.
8. Performances made in Qualification Rounds, in deciding ties in High Jump and Pole Vault, in any event or part of an event which is subsequently decreed void under the provisions of Rule 18.7 of the Competition Rules or Rule 8.4.2 of the Technical Rules, Rules 17.2 or 25.20 of the Technical Rules, in Race Walking events in which Rule 54.7.3 of the Technical Rules is applied and the athlete is not disqualified or in individual events in Combined Events competitions, regardless of whether or not the athlete completes the whole Combined Events competition, may be submitted for ratification.
9. The President and the Chief Executive Officer of World Athletics together are authorised to ratify World Records. If they are in any doubt whether or not the performance should be ratified, the case shall be referred to the Council for decision in accordance with the Governance Rules.

10. When a World Record has been ratified, the Chief Executive Officer will:
  - 10.1. so inform the athlete's Member, the Member applying for the World Record and the relevant Area Association;
  - 10.2. supply the official World Record Plaques, for presentation to World Record holders.
  - 10.3. update the official List of World Records each time a new World Record has been ratified. This list shall represent the performances regarded by World Athletics as being, from the date of the list, the best ratified performances yet set by an athlete or team of athletes in each of the recognised events listed in Rules 32, 33, 34 and 35 of the Competition Rules.
11. If the performance is not ratified, the Chief Executive Officer will give the reasons.

### **SPECIFIC CONDITIONS**

12. Except in Road Events:
  - 12.1. The performance shall be made in a World Athletics certified athletics facility or at a competition area which conforms to Rule 2 of the Technical Rules or, where applicable, Rule 11.2 of the Technical Rules.
  - 12.2. For any performance at any distance of 200m or more to be ratified, the track on which it was made shall not exceed 402.3m (440 yards) and the race shall have started on some part of the perimeter. This limitation does not apply to the Steeplechase events where the Water Jump is placed outside a normal 400m track.
  - 12.3. A performance in an oval Track Event shall be made in a lane where the running line radius does not exceed 50m, except where the bend is formed with two different radii, in which case the longer of the two arcs should not account for more than 60° of the 180° turn.
  - 12.4. A performance made in a Track Event outdoors may be made only on a track which conforms to Rule 14 of the Technical Rules.
13. For World Indoor Records:

- 13.1. The performance shall have been made in a World Athletics certified athletics facility or at a competition area, which complies with Rules 41 to 43 of the Technical Rules as applicable.
- 13.2. For races of 200m and over, the oval track may not have a nominal length of more than 201.2m (220 yards).
- 13.3. The performance may be made on an oval track with a nominal length less than 200m provided that the distance run is within permitted tolerance for the distance.
- 13.4. The performance in an oval track event shall be made in a lane where the projected running line radius on the constant banked bend segment does not exceed 27m and, for multiple lap events, the two straights each are at least 30m long.
14. For World Records in Running and Race Walking Events:
  - 14.1. The performance shall be timed by official Timekeepers, by a Fully Automatic Timing and Photo Finish System (for which a zero control test has been undertaken in accordance with Rule 19.19 of the Technical Rules) or by a Transponder System (see Rule 19.24 of the Technical Rules) complying with the Rules.
  - 14.2. For races up to and including 800m (including 4 × 200m and 4 × 400m), only performances timed by a Fully Automatic Timing and Photo Finish System complying with the Rules shall be ratified.
  - 14.3. For performances made outdoors up to and including 200m, information concerning wind velocity, measured as indicated in Rules 17.8 to 17.13 of the Technical Rules inclusive, shall be submitted. If the wind velocity, measured in the direction of running, averages more than 2 metres per second, the performance will not be ratified.
  - 14.4. No performance will be ratified where the athlete has infringed Rule 17.3 of the Technical Rules nor in the case an individual event where an athlete has recorded a false start as allowed under Rule 39.8.3 of the Technical Rules.

- 14.5. For performances up to and including 400m (including  $4 \times 200\text{m}$  and  $4 \times 400\text{m}$ ) under Rules 32 and 34 of the Competition Rules, starting blocks linked to a World Athletics certified Start Information System under Rule 15.2 of the Technical Rules must have been used and have functioned correctly so that reaction times were obtained and are shown on the results of the event.
15. For World Records set over multiple distances in the same race:
  - 15.1. A race shall be stated to be over one distance only.
  - 15.2. A race based on the distance covered over a given time may be combined with a race over a fixed distance (for example, 1 Hour and 20,000m - see Rule 18.3 of the Technical Rules).
  - 15.3. It is permissible for the same athlete to submit multiple performances for ratification in the same race.
  - 15.4. It is permissible for several athletes to submit performances for ratification in the same race.
  - 15.5. A performance will not be ratified at a shorter distance if the athlete did not finish the full distance of that race.
16. For World Records in Relay Events:

The time set by the first athlete in a relay team may not be submitted for ratification as a World Record.
17. For World Records in Field Events:
  - 17.1. The performances shall be measured either by three Field Judges using a calibrated and verified steel tape or bar or by a scientific measuring apparatus, the accuracy of which has been confirmed in accordance with Rule 10 of the Technical Rules.
  - 17.2. In the Long Jump and Triple Jump conducted outdoors, information concerning wind velocity, measured as indicated in Rules 29.10-12 of the Technical Rules shall be submitted. If the wind velocity, measured in the direction of jumping, averages more than 2 metres per second, the performance will not be ratified.
  - 17.3. World Records may be credited for more than one performance in a competition, provided that each World

- Record so ratified shall have been equal or superior to the best previous performance at that moment.
174. In Throwing Events, the implement used shall have been checked prior to the competition in accordance with Rule 16 of the Competition Rules. If the Referee becomes aware during an event that a World Record has been equalled or bettered, they shall immediately mark the implement used and undertake a check to ascertain whether it still complies with the Rules or if there has been any change in characteristics. Normally, such implement shall be checked again after the event in accordance with Rule 16 of the Competition Rules.
18. For World Records in Combined Events:  
The conditions as set out in Rule 39.8 of the Technical Rules shall have been complied with in each of the individual events. In addition, for those events where wind velocity is required to be measured, the average velocity (based on the algebraic sum of the wind velocities, as measured for each individual event, divided by the number of such events) shall not exceed plus 2 metres per second.
19. For World Records in Race Walking Events:  
At least three Judges who are either World Athletics Level or Area Level International Race Walking Judges shall be officiating during the competition and shall sign the application form.
20. For World Records in Road Race Walking Events:
201. The course must be measured by an "A" or "B" grade World Athletics/AIMS approved measurer who shall ensure that the relevant measurement report and any other information required by this Rule is available to World Athletics upon request.
202. The circuit shall be no shorter than 1km and no longer than 2km with a possible start and finish in a stadium.
203. Any course measurer who originally measured the course or other suitably qualified official designated by the measurer (after consulting the relevant body) with a copy of the documentation detailing the officially measured course must



- validate that the course covered by the athletes conforms to the course measured and documented by the official course measurer.
204. The course must be verified (i.e. re-measured) as late as possible before the race, on the day of the race or as soon as practical after the race, by a different "A" grade measurer from any of those who did the original measurement.
  205. Note: If the course was originally measured by at least two "A" or one "A" and one "B" grade measurers, no verification (re-measurement) under this Rule 31.20.4 will be required.
  206. World Records in Road Race Walking Events set at intermediate distances within a race must comply with the conditions set under Rule 31 of the Competition Rules. The intermediate distances must have been measured, recorded and subsequently marked as part of the course measurement and must have been verified in accordance with Rule 31.20.4 of the Competition Rules.
21. For World Records in Road Running Events:
- 21.1. The course must be measured by an "A" or "B" grade World Athletics/AIMS approved measurer who shall ensure that the relevant measurement report and any other information required by this Rule is available to World Athletics upon request.
  - 21.2. The start and finish points of a course, measured along a theoretical straight line between them, shall not be further apart than 50% of the race distance.
  - 21.3. The overall decrease in elevation between the start and finish shall not exceed 1:1000, i.e. 1m per km (0.1%).
  - 21.4. Any course measurer who originally measured the course or other suitably qualified official designated by the measurer (after consulting the relevant body) with a copy of the documentation detailing the officially measured course shall in advance of the race check that the course is laid out in conformity with the course measured and documented by the official course measurer. They shall then ride in the lead

vehicle during the competition or otherwise validate that the same course is run by the athletes.

215. The course must be verified (i.e. re-measured) as late as possible before the race, on the day of the race or as soon as practical after the race, by a different "A" grade measurer from any of those who did the original measurement.

*Note: If the course was originally measured by at least two "A" grade or one "A" and one "B" grade measurers, no verification (re-measurement) under this Rule 31.21.5 will be required.*

216. World Records in Road Running Events set at intermediate distances within a race must comply with the conditions set under Rule 31 of the Competition Rules. The intermediate distances must have been measured, recorded and subsequently marked as part of the course measurement and must have been verified in accordance with Rule 31.21.5 of the Competition Rules.

217. For the Road Relay, the race shall be run in stages of 5km, 10km, 5km, 10km, 5km, 7.195km. The stages must have been measured, recorded and subsequently marked as part of the course measurement with a tolerance of  $\pm 1\%$  of the stage distance and must have been verified in accordance with Rule 31.21.5 of the Competition Rules.

*Note: It is recommended that national governing bodies and Area Associations adopt similar rules to the above for the recognition of their own records*

## **RULE 32 EVENTS FOR WHICH RECORDS ARE RECOGNISED**

Fully Automatically Timed performances (F.A.T.)

Hand Timed performances (H.T.)

Transponder Timed performances (T.T.)

### **MEN**

Running, Combined and Race Walking Events:

F.A.T. only:

1. 100m; 200m; 400m; 800m;
2. 110m Hurdles; 400m Hurdles;
3. 4 × 100m Relay; 4 × 200m Relay; 4 × 400m Relay;
4. Decathlon.

F.A.T. or H.T.:

1. 1000m; 1500m; 1 Mile; 2000m; 3000m;
2. 5000m; 10,000m; 1 Hour;
3. 3000m Steeplechase;
4. 4 × 800m Relay; Distance Medley Relay; 4 × 1500m Relay;
5. Race Walking (Track): 20,000m; 30,000m, 50,000m.

F.A.T. or H.T. or T.T.:

1. Road Races: 5km\*; 10km; Half Marathon; Marathon; 100km; Road Relay (Marathon distance only);
2. Race Walking (Road): 20km; 50km.

Jumping Events:

1. High Jump; Pole Vault; Long Jump; Triple Jump.

Throwing Events:

1. Shot Put; Discus Throw; Hammer Throw; Javelin Throw.

**WOMEN**

Running, Combined and Race Walking Events:

F.A.T. only:

1. 100m; 200m; 400m; 800m;
2. 100m Hurdles; 400m Hurdles;
3. 4 × 100m Relay; 4 × 200m Relay; 4 × 400m Relay;
4. Heptathlon; Decathlon.

F.A.T. or H.T.:

1. 1000m; 1500m; 1 Mile; 2000m; 3000m;
2. 5000m; 10,000m; 1 Hour;
3. 3000m Steeplechase;
4. 4 × 800m Relay; Distance Medley Relay; 4 × 1500m Relay;
5. Race Walking (Track): 10,000m; 20,000m; 50,000m.

F.A.T. or H.T. or T.T.:

1. Road Races: 5km\*; 10km; Half Marathon; Marathon; 100km; Road Relay (Marathon distance only);
2. Race Walking (Road): 20km; 50km.

*Note (i): Except Race Walking competitions, World Athletics shall keep two World Records for women in Road Races: a World Record for performance achieved in mixed gender (“Mixed”) races and a World Record for performance achieved in single gender (“Women only”) races.*

*Note (ii): A women only road race can be staged by having separate women’s and men’s start times. The time differential should be chosen to prevent any possibility of assistance, pacing or interference, especially on courses involving more than one lap of the same section of the course.*

\*Initial record to be recognised after 1 January 2018.

°Initial record to be recognised after 1 January 2019. The performance shall be better than 4:20:00.

Jumping Events:

High Jump; Pole Vault; Long Jump; Triple Jump.

Throwing Events:

Shot Put; Discus Throw; Hammer Throw; Javelin Throw.

## **UNIVERSAL**

Running, Combined and Race Walking Events:

F.A.T. only:

1. 4 × 400m Relay (mixed)

## **RULE 33 EVENTS FOR WHICH WORLD U20 RECORDS ARE RECOGNISED**

Fully Automatically Timed performances (F.A.T.)

Hand Timed performances (H.T.)

Transponder Timed performances (T.T.)

## **U20 MEN**

Running, Combined and Race Walking Events:

F.A.T. only:

1. 100m; 200m; 400m; 800m;
2. 110m Hurdles; 400m Hurdles;
3. 4 × 100m Relay; 4 × 400m Relay;
4. Decathlon.

F.A.T. or H.T.:

1. 1000m; 1500m; 1 Mile; 3000m;
2. 5000m; 10,000m; 3000m Steeplechase;
3. Race Walking (Track): 10,000m.

F.A.T. or H.T. or T.T.:

1. Race Walking (Road): 10km.

Jumping Events:

High Jump; Pole Vault; Long Jump; Triple Jump.

Throwing Events:

Shot Put; Discus; Hammer Throw; Javelin Throw.

## **U20 WOMEN**

Running, Combined and Race Walking Events:

F.A.T. only:

1. 100m; 200m; 400m; 800m;
2. 100m Hurdles; 400m Hurdles;
3. 4 × 100m Relay; 4 × 400m Relay;
4. Heptathlon, Decathlon\*.

F.A.T. or H.T.:

1. 1000m; 1500m; 1 Mile; 3000m;
2. 5000m; 10,000m; 3000m Steeplechase;
3. Race Walking (Track): 10,000m.

F.A.T. or H.T. or T.T.:

1. Race Walking (Road): 10km.

Jumping Events:

High Jump; Pole Vault; Long Jump; Triple Jump.

Throwing Events:

Shot Put; Discus Throw; Hammer Throw; Javelin Throw.

\*Only ratified if over 7300 points.

## **RULE 34 EVENTS FOR WHICH WORLD INDOOR RECORDS ARE RECOGNISED**

Fully Automatically Timed performances (F.A.T.)

Hand Timed performances (H.T.)

## **MEN**

Running, Combined and Race Walking Events:

F.A.T. only:

1. 50m; 60m; 200m; 400m; 800m;
2. 50m Hurdles; 60m Hurdles;
3. 4 × 200m Relay; 4 × 400m Relay;
4. Heptathlon.

F.A.T. or H.T.:

1. 1000m; 1500m; 1 Mile; 3000m; 5000m;
2. 4 × 800m Relay;
3. Race Walking: 5000m.

Jumping Events:

High Jump; Pole Vault; Long Jump; Triple Jump.

Throwing Event:

Shot Put.

## **WOMEN**

Running, Combined and Race Walking Events:

F.A.T. only:

1. 50m; 60m; 200m; 400m; 800m;
2. 50m Hurdles; 60m Hurdles;
3. 4 × 200m Relay; 4 × 400m Relay;
4. Pentathlon.

F.A.T. or H.T.:

1. 1000m; 1500m; 1 Mile; 3000m; 5000m;
2. 4 × 800m Relay;
3. Race Walking: 3000m.

Jumping Events:

High Jump; Pole Vault; Long Jump; Triple Jump.

Throwing Event:

Shot Put.

**RULE 35 EVENTS FOR WHICH WORLD U20 INDOOR  
RECORDS ARE RECOGNISED**

Fully Automatically Timed performances (F.A.T.)

Hand Timed performances (H.T.)

**MEN**

Running and Combined Events:

F.A.T. only:

1. 60m; 200m; 400m; 800m;
2. 60m Hurdles;
3. Heptathlon.

F.A.T. or H.T.:

1. 1000m; 1500m; 1 Mile; 3000m; 5000m.

Jumping Events:

High Jump; Pole Vault; Long Jump; Triple Jump.

Throwing Event:

Shot Put.

**WOMEN**

Running and Combined Events:

F.A.T. only:

1. 60m; 200m; 400m; 800m;
2. 60m Hurdles;
3. Pentathlon.

F.A.T. or H.T.:

1. 1000m; 1500m; 1 Mile; 3000m; 5000m.

Jumping Events:

High Jump; Pole Vault; Long Jump; Triple Jump.

Throwing Event:

Shot Put.

**RULE C35 (264) S1 UKA SUPPLEMENT  
RECORDS**

The UKA Technical Advisory Committee (TAG) is responsible for the management and sanction of British records

- (1) An application for a record must be made on the appropriate form which must be forwarded with a copy of the programme, and in the case of a field event, the score card, within 14 days to the Secretary of the appropriate National Association in respect of Home Country records, by the Secretary of the body responsible for the organisation of the meeting at which the performance was accomplished.
- (2) If an application concerns a UKA National or All-comers record or in respect of a foreign athlete and the claim for a National Record, a Record of Performance form should be completed and forwarded to the Chief Executive of UKA, together with other appropriate details.
- (3) The standard record form shall, as appropriate, state or confirm:
  - (i) Place.
  - (ii) Date.
  - (iii) Name and affiliation of the competitor.
  - (iv) Performance.
  - (v) Force and direction of wind.
  - (vi) Correctness as to the distance covered by the competitor in the race.
  - (vii) Correctness as to spacing and type of hurdle used, and the number knocked down if not of the International type.
  - (viii) Correctness of time, distance or height claimed.
  - (ix) Correctness of weight, measurement and material of implement.
  - (x) The time at the end of each lap and the name of the leader for all events over 400m in length.
  - (xi) That the appropriate Rules of UKA and/or World Athletics have been strictly observed.
- (4) The appropriate Referee must sign the record form, confirming the accuracy of all the details included in the application form and supporting information.
- (5) Claims for outdoor records will not be accepted if the performance was achieved on a wooden surface, or, in the case of all running and walking events, if the track was banked. Separate indoor records are maintained for which these restrictions do not apply.
- (6) No outdoor record at a distance of 200m or more shall be accepted if made on a track exceeding 400 metres in perimeter or if not started on the perimeter, except in steeplechase events where the water jump is placed outside the normal 400 metre track.



- (7) For outdoor records the maximum lateral inclination of tracks, runways or circles shall not exceed 1:100 and in the running direction 1:1000 downwards; any inclination should be uniform. The inclination of a throwing field shall not exceed 1:1000 downwards in the throwing direction.
- (8) When photo finish or an approved fully automatic electrical timing device is used the time for distances up to and including 10,000m, unless recorded as an exact 1/100th of a second, shall be read and recorded to the next longer 1/100th of a second. For distances over 10,000m the time shall be read and recorded to 1/10th second. Record claims for events up to and including 400m can only be submitted when such a device has been used for timing.
- (9) Where a record claim is made when hand timing only is in operation the performance must have been timed by three Timekeepers each of whom should be at least Level 4. Immediately after the race they shall exhibit their watches to the Chief Timekeeper who will decide which time shall be recorded in accordance with Rule T19.11 and complete the Record Application Form appropriately.
- (10) All the Track Officials signing the Record Application Form should be at least Level 4.
- (11) For records claimed in Walking Events the Chief Judge of Walking must certify that the competitor complied fully with the definition of walking. The certification shall not be given unless there are four Judges of Race Walking, of whom at least three shall be at least Level 4 or its equivalent or be on the World Athletics Panel.
- (12) In a race run wholly or partly in lanes no record shall be accepted where the athlete has run on, or inside, the inner curved border of his or her lane.
- (13) For records claimed in Field Events the distance or height shall have been measured by three Field Judges using EDM, VDM, or other scientific apparatus, which has obtained a certificate of accuracy from a nationally recognised standardising organisation. Alternatively, in certain circumstances a steel or fibre glass tape, or bar may be used. The Field Referee should be at least Level 4 and the other Judges signing the result card should be qualified officials.
- (14) For all outdoor record claims up to 200m on the track and in the Long Jump and Triple Jump information as to wind conditions must be available. If the component of the wind measured in the direction

of running behind the runner averages more than 2 metres per second the performance shall not be accepted as a record except as outlined in (19) below. The wind gauge must have been sighted in accordance with Rules T17, T19 and T29 as appropriate.

- (15) The periods for which the wind component shall be measured are as follows:

All distances up to and including 100m	10 secs
100m hurdles and 110m hurdles	13 secs
Long jump and triple jump	5 secs
200m Commencing as the runners enter the straight	10 secs

Wind speeds shall be recorded in accordance with rule T17, T19 and T29.

- (16) The record claimed must have been made in a bona fide competition included in the programme of the meeting where it was held. Record claims may be submitted for performances made in heats or qualifying trials, and in Combined Events.
- (17) No performance will be accepted in an individual event unless it has been accomplished during an official competition with a minimum of three competitors taking part. At least two relay teams must have participated in any relay race for a record to be considered.
- (18) Except in Field Events no performances achieved in a Handicap shall be accepted as a record.
- (19) Outdoor records in Combined Events will be accepted only if performances in each event of which the competition consists are certified in accordance with the preceding paragraphs of this Rule, except that in events where wind velocity is measured, the average velocity (based on the sum of the wind velocities, as measured for each individual event, divided by the number of such events) shall not exceed + 2 metres per second.
- (20) In any race decided on the distance covered in a fixed period of time the distance achieved shall be measured to the nearest metre behind the rear edge of the last foot-print of the competitor, i.e. fractions of a metre shall be ignored.
- (21) In the case of United Kingdom records UKA will decide whether the competition was a bona fide one and shall have absolute and unfettered discretion in deciding whether to accept or to refuse a record claim. Provided the essential Rules for Competition have

been observed it is a matter for UKA to decide whether the omission of any technicality can be ignored.

**(22) Events for which United Kingdom All-Comers and National Records are recognised outdoors are:**

**Men and Women (Seniors):** 100m, 200m, 400m, 800m, 1000m, 1500m, 1 Mile, 2000m, 3000m, 5000m, 10000m, 1 Hour, 25000m, 30000m, 400m Hurdles, 3000m Steeplechase, 4x100m, 4x400m, High Jump, Pole Vault, Long Jump, Triple Jump, Shot Put, Discus, Hammer, Javelin, Decathlon, 20km Walk, 2 Hours Walk, 30km Walk, 50km Walk.

**Men only (Seniors):** 110m Hurdles, 4x200m, 4x800m,

**Women only (Seniors):** 100m Hurdles, Heptathlon.

**Mixed (Seniors):** 4x400m Relay

**(23) Events for which United Kingdom National Under 23 Records are recognised outdoors are:**

**Men and Women:** 100m, 200m, 400m, 800m, 1000m, 1500m, 1 Mile, 2000m, 3000m, 5000m, 10000m, 1 Hour, 25000m, 30000m, 400m Hurdles, 3000m Steeplechase, 4x100m, 4x400m, High Jump, Pole Vault, Long Jump, Triple Jump, Shot Put, Discus, Hammer, Javelin, Decathlon, 20km Walk, 30km Walk, 50km Walk.

**Men only:** 110m Hurdles, 4x200m, 4x800m,

**Women only:** 100m Hurdles, Heptathlon.

**(24) Events for which United Kingdom National U20 Records (Juniors) are recognised outdoors (using Senior or Under 20 specifications) are:**

**Men and Women:** 100m, 200m, 400m, 800m, 1000m, 1500m, 1 Mile, 3000m, 5000m, 10000m, 400m Hurdles, 3000m Steeplechase, High Jump, Pole Vault, Long Jump, Triple Jump, Shot Put, Discus, Hammer, Javelin, Decathlon, 10km Walk.

**Men only:** 110m Hurdles.

**Women only:** 100m Hurdles, Heptathlon.

**(25) Events for which United Kingdom National U18 Records are recognised outdoors (using Under 18 specifications only) are:**

**Men and Women:** 100m, 200m, 400m, 800m, 1000m, 1500m, 1 Mile, 3000m, 400m Hurdles, 2000m Steeplechase, High Jump, Pole Vault, Long Jump, Triple Jump, Shot Put, Discus, Hammer, Javelin, 10km Walk.

**Men only:** 110m Hurdles, Decathlon.

**Women only:** 100m Hurdles, 5km Walk, Heptathlon.

**(26) Events for which United Kingdom All-Comers and National records are recognised indoors are:**

**Men and Women:** 50m, 60m, 200m, 400m, 800m, 1000m, 1500m, 1 Mile, 3000m, 5000m, 50m Hurdles, 60m Hurdles, 4x200m, 4x400m, 4x800m, High Jump, Pole Vault, Long Jump, Triple Jump, Shot Put.

**Men only:** 5km Walk, Heptathlon.

**Women only:** 3km Walk, Pentathlon.

(27) Indoor records at 200m and over are only valid if the oval track does not have a nominal length of more than 200 metres.

(28) Additional United Kingdom National Records will be added from time to time during the duration of this rule book by UKA Technical Advisory Group for events which have become established at National championships.

(29) **Ratification of Records and Doping Control:** Prior to ratification of a new record achieved at a competition where testing has not been conducted, a review may be undertaken of the athlete's testing history which may include checking test pool membership, test frequency etc. Where testing is present at an event where a record is broken the athlete should request a test. If the athlete fails to report for testing, then they may be asked to provide an explanation for the

failure to report for testing for consideration as part of the ratification process.

### **RULE 36 OTHER RECORDS**

1. Games, championships, meeting and other similar records may be established by the relevant body having control over the competition or by the organisers.
2. The record should recognise the best performance achieved at any edition of the applicable competition in accordance with the Rules, with the exception that wind velocity readings may be ignored, if so, stated in the applicable regulations for the competition.

## TECHNICAL RULES

### SECTION I – GENERAL

#### RULE 1 GENERAL

All International Competitions, as defined in the Generally Applicable Definitions, shall be held under the Rules of World Athletics.

In all competitions, events may be held in a different format from that provided under the Technical Rules, but rules giving more rights to the athletes than they would have obtained applying the actual Rules, may not be applied. These formats shall be decided or authorised by the relevant governing body having the control over the competition.

In the case of mass participation events held outside the stadium, these Rules should normally only be applied in full to those athletes, if any, who are designated as taking part in the elite or other defined section of the races such as age group categories for which there are placings for awards or prizes. Race organisers should outline in the information provided to other athletes which other rules will apply to their participation, particularly those pertaining to their safety.

*Note: It is recommended that Members adopt the Rules for the conduct of their own athletics competitions.*

Whilst these Rules already contemplate some variations from their strictest applications, it is emphasised that competition organisers may go even further in using different formats for competitions - the only restriction being that the athlete may not receive more “rights” in such circumstances. For example, it is acceptable to reduce the number of trials in a Field Event or reduce the time allowed for an athlete to take their trial but not to increase either.

With respect to mass participation Running and Race Walking Events, it is prescribed that these Rules shall only be fully applied to any elite component of the event or any other part designated by the organisers where there is a logical reason to do so, e.g. because of significant awards or prizes.

However, race organisers are advised to emphasise in the information provided to all participants the rules and procedures that will apply to the various categories, especially in relation to safety considerations, particularly when all or part of the race is not closed to traffic. This may for example allow athletes (other than those competing in the elite or other categories to whom Rule 6.3 of the Technical Rules would apply) to use head or earphones when they are running on a closed course but prohibit their use (or at least recommend against it) for the slower runners when the course is open to traffic.

## **RULE 2 THE ATHLETICS FACILITY**

Any firm, uniform surface that conforms to the specifications in the Track and Field Facilities Manual, may be used for Track and Field Athletics.

Outdoor competitions 1.1 of the International Competition definition may be held only on facilities that hold a World Athletics Class 1 Athletics Facility Certificate. It is recommended that, when such facilities are available, outdoor competitions under paragraphs 1.2 to 1.10 of the International Competition definition should also be held on these facilities.

In any case, a World Athletics Class 2 Athletics Facility Certificate shall be required for all facilities intended for use for outdoor competitions under paragraphs 1.2 to 1.10 of the International Competition definition.

*Note (i): The World Athletics Track and Field Facilities Manual, which is available from the World Athletics Office, or may be downloaded from the World Athletics website, contains more detailed and defined specifications for the planning and construction of Track and Field facilities including further diagrams for track measurement and marking.*

*Note (ii): The current standard forms required to be used for the certification application and measurement report as well as the Certification System Procedures are available from the World Athletics Office or may be downloaded from the World Athletics website.*

*Note (iii): For Road Race Walking, Road Running or Cross Country, Mountain and Trail courses, see Rules 54.11, 55.2, 55.3, 56.1-5, and 57.1 of the Technical Rules.*

*Note (iv): For the indoor athletics facility, see Rule 41 of the Technical Rules.*

### **RULE 3 AGE AND SEX CATEGORIES**

#### **AGE AND SEX CATEGORIES**

1. Competition under these Rules may be divided into age group classifications as follows or as additionally prescribed in the relevant competition regulations or by the relevant governing body:  
Under-18 (U18) Men and Women: Any athlete of 16 or 17 years on 31st December in the year of the competition.  
Under-20 (U20) Men and Women: Any athlete of 18 or 19 years on 31st December in the year of the competition.  
Master Men and Women: Any athlete who has reached their 35th birthday.

*Note (i): All other matters concerning Masters' competitions are referred to the World Athletics/WMA Handbook approved by World Athletics and WMA.*

*Note (ii): Eligibility, including minimum ages for participation in Competitions, shall be subject to the applicable Technical Regulations.*

2. An athlete shall be eligible to compete in an age group competition under these Rules if they are within the age range specified in the relevant age group classification. An athlete must be able to provide proof of their age through presentation of a valid passport or other form of evidence as permitted by the applicable regulations for the competition. An athlete who fails or refuses to provide such proof shall not be eligible to compete.

*Note: See Eligibility Rules for sanctions for non-compliance with this Rule 3.*



Whilst Rule 3.1 of the Technical Rules defines the age groups in a particular way, it is the regulations for each competition which determine which age groups will apply and whether, as envisaged by Note (ii), younger athletes can participate.

### SEX CATEGORIES

3. Competition under these Rules is divided into men's, women's and universal classifications. When a mixed competition is conducted outside the stadium or in one of the limited cases set out in Rule 9 of the Technical Rules, separate men's and women's classification results should still be declared or otherwise indicated. When a universal event or competition is conducted a single classification result only shall be declared.
4. An athlete shall be eligible to compete in men's (or universal) competition if they either were born and, throughout their life, have always been recognised as a male or comply with the applicable Regulations issued pursuant to Rule 3.6.1 of the Technical Rules and are eligible to compete under the Rules and Regulations.
5. An athlete shall be eligible to compete in women's (or universal) competition if they either were born and, throughout their life, have always been recognised as a female or comply with the applicable Regulations issued pursuant to Rule 3.6.2 of the Technical Rules and are eligible to compete under the Rules and Regulations.
6. The Council shall approve Regulations to determine the eligibility for:
  - 6.1. men's competition of males who are female to male Transgender;
  - 6.2. women's competition for females who are male to female Transgender; and
  - 6.3. women's competition for female classification (athletes with differences in sex development).

An athlete who fails or refuses to comply with the applicable regulations shall not be eligible to compete.

*Note: See Eligibility Rules for sanctions for non-compliance with this Rule 3.*

Universal competition covers events in which men and women participate together without separate classification of results as well as relay or team events in which both men and women are included in the same teams.

### **RULE T3 (141) S 1 UKA SUPPLEMENT ADDITIONAL UKA AGE GROUPS**

The Competition Year for Cross Country and Road Running Events shall be from 1st September each year to the following 31st August. The Competition Year for Fell, Hill and Mountain Events shall be from 1 January to 31 December each year. The Competition Year for all other disciplines shall be from 1st October each year to the following 30th September.

The operative date for determining membership of age groups for all athletes under the age of 17 shall be for Track and Field and Race Walking, the 31st August at the end of the Competition Year, and for all other disciplines, the 31st August prior to the commencement of the Competition Year.

*NOTE 1: In Northern Ireland the qualifying date for all disciplines is taken at 31st December at the end of the year of competition.*

*NOTE 2: UKA Rules do not cater for athletes under the age of 11 years. This does not necessarily preclude provision by Competition Providers for events for athletes younger than 11 years, with correspondingly reduced distances to run.*

### **RULE T3 (141) S 2 UKA SUPPLEMENT TRACK AND FIELD AND RACE WALKING**

#### **(1) Under 13 Boys and Girls (School Years 6 and 7)**

- (i) Track and Field competition for Under 13s shall be confined to competitors who are aged 11 or 12 on the 31st August within the Competition Year, as defined above.
- (ii) Other than when competing in a combined event Under 13s may compete in a maximum of 4 events on one day of an athletics meeting, and if so doing, one of these must be a relay.

Where a walking event is included in the total, the competitors shall be restricted to maximum of 3 running or walking event (including any relay) in one day. The total distance covered shall not exceed the maximum listed in Rule T3 S2(8). If athletes in this age group are competing in a combined event they are not allowed to compete in any other event on the same day.

- (iii) Athletes in this age group may compete in track races not exceeding one mile subject to the restrictions in (iv) below. No Under 13 athlete is allowed to compete in any steeplechase event.
- (iv) No athlete in this age group is allowed to compete in any race at 300 metres and 400 metres, nor in more than one race between 600 metres and one mile inclusive on the same day.
- (v) Under 13s may run against Under 15 Boys or Girls, as appropriate, in track events not exceeding one mile, subject to any limitations as to standard laid down by the Competition Provider. They may not take part in competitions for older athletes other than those in the Under 15 age group
- (vi) Under 13s may compete against Under 15 Boys or Girls, as appropriate, in field events, provided that the implements used by them shall be those laid down for the Under 15 age group. They may not take part in competitions for older athletes other than those in the Under 15 age group.
- (vii) No athlete in this age group is allowed to compete in Triple Jump events.

**(2) Under 15 Boys and Girls (School Years 8 and 9)**

- (i) Track and Field events for Under 15s shall be confined to competitors who are aged 13 or 14 on 31st August within the Competition Year, as defined above.
- (ii) Other than when competing in a combined event Under 15s may compete in maximum of 4 events on one day of an athletics meeting, and if so doing, one of these must be a relay. Where a walking event is included in the total, the competitors shall also be restricted to a maximum of 3 running or walking events (including any relay) in one day. The total distance covered shall not exceed the maximum listed in Rule T3 S2(8). If Under

15s are competing in a combined event they are not allowed to compete in any other event on the same day.

- (iii) No athlete in this age group is allowed to run in any race in excess of 3000 metres.
  - (iv) No athlete in this age group is allowed to run in more than one different event between 600 metres and 3000 metres inclusive on the same day.
  - (v) Under 15 athletes may compete in Steeplechase races over 1500m and a hurdle height of 0.762m on the understanding that this will be a development event.
  - (vi) Under 15 athletes may compete against Under 17 Men and Women, as appropriate, in track events not exceeding 1 mile (but not steeplechase), subject to any limitations as to standard laid down by the Competition Provider. They may not take part in competitions for older athletes other than those in the Under 17 age group.
  - (vii) Under 15s may compete against Under 17 Men or Women, as appropriate, in field events, provided that the implements used by them shall be those laid down for the Under 17 age group. They may not take part in competitions for older athletes other than those in the Under 17 age group.
  - (viii) National Age Group Leagues and Home Country Championships will provide 300 metres races for the Under 15 age group. Other Competition Providers may use their discretion and include a 400 metres for Under 15 athletes within their programmes.
- (3) Under 17 Men and Women (School Years 10 and 11)**
- (i) Track and Field events for Under 17s shall be confined to competitors who are aged 15 or 16 on 31st August within the Competition Year, as defined above.
  - (ii) Other than when competing in a combined event, Under 17s may compete in maximum of four events on one day of an athletics meeting, and if so doing, one of these must be a relay. If Under 17s are competing in a combined event they are not allowed to compete in any other event on the same day.
  - (iii) No athlete in this age group is allowed to run in any track event in excess of 5000 metres.

- (iv) Under 17 athletes may compete against Under 20s or Seniors in track events, including National and County Championships, in events not exceeding 3000 metres (including steeplechase), subject to any limitations as to standard laid down by the Competition Provider.
- (v) Under 17s may compete against Under 20s or Seniors in field events, provided the implements to be used are those laid down for the older age group.

**(4) Under 20 Years Men and Women**

- (i) Track and Field events for Under 20s shall be confined to competitors who are 17 or over on 31st August within the Competition Year, as defined above, but Under 20 on 31st December in the calendar year of competition.
- (ii) Under 20s may not compete in more than five events on the same day of an athletics meeting. If Under 20s are competing in a combined event they are not allowed to compete in any other event on the same day.
- (iii) Under 20s may only run in track events up to and including 10000 metres.
- (iv) Under 20s may run against Seniors in open track events, including National and County Championships, up to and including 10,000 metres.
- (v) Under 20s may compete against Seniors in open field event competitions, including National and County Championships, provided that the implements used by them shall be those laid down for Senior competition.

**(5) Seniors**

- (i) A Senior is a competitor who is at least 20 years of age on 31st December in the calendar year of competition.

**(6) Masters**

- (i) Events for Masters shall be confined to athletes who are at least 35 years of age on the day of competition.

**(7) Graded Events**

- (i) The organisers of a graded competition may allow competitors in younger age groups to compete against older athletes provided that the conditions do not contravene any rules regarding distances or events which may be contested. The Rule for Mixed Graded Competitions is Rule T9 S1.

## Race Walking

The maximum permitted distances for Race Walking events (track and road) shall be:

Age Group	Maximum Distance All Athletes
Under 13 years	3,000 metres
Under 15 years	5,000 metres
Under 17 years	15,000 metres
Under 20 years	20,000 metres
Seniors	Unlimited

Ages for maximum distances are as at 31st August in the year of competition.

### **RULE T3 (141) S 3 UKA SUPPLEMENT CROSS COUNTRY AND ROAD AGE GROUPS**

(1) Road Race Competition Providers may make such age limits as they think fit provided that the conditions of the race do not contravene any rules regarding distances which may be run, and provided that the race is not advertised under the title of any of the recognised age categories as listed below.

**(i) Under 13 Boys and Girls (School Years 7 & 8 and some year 6)**

Cross Country and Road Running competitions for Under 13s shall be confined to competitors who are aged 11 on the day of competition, or 12 on 31st August prior to the commencement of the Competition Year as defined above.

**(ii) Under 15 Boys & Girls (School Years 9 & 10)**

Cross Country and Road Running competitions for Under 15s shall be confined to competitors who are aged 13 or 14 on 31st August prior to the commencement of the Competition Year as defined above.

**(iii) Under 17 Men & Women (School Years 11 & 12)**

Cross Country and Road Running competitions for Under 17s shall be confined to competitors who are aged 15 or 16 on 31st

August prior to the commencement of the Competition Year as defined above.

**(iv) Under 20 Men & Women**

Cross Country and Road Running competitions for Under 20 Men and Women shall be confined to competitors who are aged 17, 18 or 19 on 31st August prior to the commencement of the Competition Year as defined above.

**(v) Senior Men & Women**

For Cross Country and Road Running competitions a Senior is a competitor who is aged at least 20 years on 31st August prior to the commencement of the Competition Year as defined above. In Road Relay Competitions Under 20 Men and Women, as appropriate, may compete in Senior events.

**(vi) Masters Men and Women**

Cross Country and Road Running events for Masters shall be confined to competitors who are at least 35 years of age on the date of the competition.

**(2) Cross Country Maximum Distances**

Age Group	Maximum Distance All Athletes
Under 13 years	3,500 metres
Under 15 years	5,000 metres
Under 17 years	6,500 metres
Under 20 years	10,000 metres
Seniors	Unlimited

**(3) Road Maximum Distances**

Age on day of competition	Maximum Distance All Athletes
Over 11 – Under 13	5,000 metres
Over 13 – Under 15	6,000 metres
Aged 15 years	10,000 metres
Aged 16 years	15,000 metres
Aged 17 years	25,000 metres
Over 18 – Under 20	Marathon

Seniors	Unlimited
Masters	Unlimited

### **RULE T3 (141) S 4 UKA SUPPLEMENT FELL, HILL AND MOUNTAIN RUNNING**

Competition Providers must stipulate age limits for their events but the following limits for younger runners must be observed:

The maximum distances for younger runners shall be:

Age on 31st December in year of competition	Maximum Distance
Under 13 years	All Athletes
Under 15 years	3,000 metres
Under 17 years	5,000 metres
Under 19 years	7,000 metres
	10,000 metres

For paired Mountain Marathon style orienteering events, over one or two days, where one of the two runners is under 18, the other runner must be over 20 and must also be the parent or guardian of the junior runner. For paired Mountain Marathon style orienteering events the age limits refer to the age of the competitors on the day of the event. The minimum age for the junior runner is 14 and the following straight line distance limits must apply for each day of the event.

Under 16 years	20,000 metres
Under 18 years	25,000 metres

### **RULE T3 (141) S 5 UKA SUPPLEMENT TRAIL RUNNING**

Subject to satisfying HSE ‘Adventure Activity Licensing Regulations’ for youths under eighteen, the maximum distances permitted for the following age groups are:

Under 12 years	3,000 metres
Under 14 years	5,000 metres
Under 16 years	6,000 metres
Under 17 years	10,000 metres



Under 18 years 25,000 metres

Under 20 years 45,000 metres

**Veteran Men and Women:** For Trail Running a veteran is a competitor aged at least 40 years on the day of the competition.

#### **RULE 4 ENTRIES**

1. Competitions under the Rules are restricted to eligible athletes.
2. The eligibility of an athlete to compete outside of their own country is as set forth in Requirements to Compete in International Competitions Rules. Such eligibility shall be assumed unless an objection to their status is made to the Technical Delegate(s). (See also Rule 8.1 of the Technical Rules.)

#### **SIMULTANEOUS ENTRIES**

3. If an athlete is entered in both a Track Event and a Field Event, or in more than one Field Event taking place simultaneously, the appropriate Referee may, for one round of trials at a time, or for each trial in the High Jump and Pole Vault, allow an athlete to take their trial in an order different from that decided upon by the draw prior to the start of the competition. However, if an athlete subsequently is not present for a particular trial, it shall be deemed that they are passing once the period allowed for the trial has elapsed.

*Note: In Field Events, the Referee shall not allow an athlete to take a trial in a different order in the final round of trials, but the Referee may allow an athlete to do so during any earlier round of trials. In Combined Events, a change may be allowed in any round of trials.*

The Note clarifies that allowing an athlete to take a trial in a different order in the final round of trials (irrespective of the number of rounds of trials) because of a clash with another event is not permitted. If an athlete is not present in the final round and has not previously indicated that they will pass, then the time allowed for their trial will run and if they do not return before it expires, then they will be recorded as passing. [See also Rule 25.18 of the Technical Rules where a change of order will normally not be made when a replacement trial is awarded - in any round of trials.]

Whilst Rules 4.3 and 26.2 of the Technical Rules provide that an athlete may not attempt the second or third trial at any particular height in Vertical Jumps if it has been deemed that they have passed an earlier trial at that height, it is suggested that in lower level competitions such as children's and school meets that the competition regulations could be adapted so as to allow an athlete to opt to take the second or third trial in such cases.

## **FAILURE TO PARTICIPATE**

4. At all competitions under paragraphs 1.1, 1.2, 1.3 and 1.6 of the International Competition definition, an athlete shall be excluded from participation in all further events (including other events in which they are simultaneously participating) in the competition, including relays, in cases where:

4.1. final confirmation was given that the athlete would start in an event but then failed to participate;

*Note: A fixed time for the final confirmation of participation shall be published in advance.*

4.2. an athlete qualified in any Qualification Round of an event for further participation in that event but then failed to participate further;

*NOTE: For the avoidance of doubt, Rules 4.4.2 and 4.4.3 shall apply to all competitions held under UKA rules.*

4.3. an athlete failed to compete honestly with bona fide effort. The relevant Referee will decide on this and the corresponding reference must be made in the official results.

*Note: The situation foreseen in Rule 4.4.3 of the Technical Rules will not apply to individual events within Combined Events.*

*NOTE: A decision by the Referee that an athlete failed to compete honestly and with bona fide effort would not constitute grounds for disqualification in the event in which that was judged to be the case (i.e. only exclusion from subsequent or concurrent events)*

*This rule applies where competition in further events is possible such as at Championship events, rather than in League competitions.*

However, a medical certificate, provided by and based on an examination of the athlete by the Medical Delegate appointed under Rule 6 of the Competition Rules or, if no Medical Delegate has been so appointed, by a medical doctor so designated by the Organisers, may be accepted as sufficient reason to accept that the athlete became unable to compete after confirmations closed or after competing in a previous round but will be able to compete in further events (except Combined Events individual events) on a subsequent day of the competition. Other justifiable reasons (e.g. factors independent of the athlete's own actions, such as problems with the official transport system) may, after confirmation, also be accepted by the Technical Delegate(s).

The relevant Referee, once aware of such a situation and is satisfied that the athlete who abandoned the race was not competing with a bona fide effort, must make a reference to this in the relevant results as "DNF Rule 4.4.3 TR". Either in the process of the Referee making such a decision or the Jury of the Appeal considering any protest arising from it, reasons for the withdrawal or non-participation proposed by or on behalf of the athlete can be considered. The Rule sets out the process that should explicitly be followed in the case of a medical reason.

#### **FAILURE TO REPORT TO THE CALL ROOM(S)**

5. Subject always to any additional sanction under Rule 4.4 of the Technical Rules, and except as provided below, an athlete shall be excluded from participation in any event in which they are not present in the Call Room(s) at the relevant time as published in the Call Room schedule (see Call Room Judges Rule of the Competition Rules). They shall be shown in the results as DNS.

The relevant Referee will decide on this (including whether the athlete may compete under protest if a decision cannot be made immediately) and the corresponding reference must be made in the official results.

Justifiable reasons (e.g. factors independent of the athlete's own actions, such as problems with the official transport system or an

error in the published Call Room schedule) may, after confirmation, be accepted by the Referee and the athlete may then be allowed to take part.

**RULE T4 (142) S 1 UKA SUPPLEMENT  
ENTRIES**

- (1) Every entry, either by hard copy or electronically as required by the Competition Provider, shall be made to the authorised official of the Competition Provider. Every entry must be dated and state fully and accurately the particulars required by the official entry form, including the true, legally registered name, address, date of birth, National Association Registration Number and affiliated Club of the competitor. No one shall be allowed to compete unless an entry form is completed in accordance with this Rule and anyone whose entry form is not so completed shall forfeit the entrance fee.
- (2) Any Competition Provider has the right to refuse any entry without assigning a reason to the entrant, but the reason must be disclosed to the Licensing Authority if requested.
- (3) No entry either for individual or team events may be made except upon the form of entry issued or approved by the Licensing Authority.
- (4) Every individual entry shall be confirmed by the intending competitor, who shall be responsible for all statements therein and any omissions there from, whether the athlete actually made the entry or not. Any individual making a false entry shall be dealt with for misconduct. (as defined in Rule T7 S1).
- (5) Every entry for an event limited by age shall state the date of birth of the intending competitor and every such entry shall, if required, be verified subsequently by the production of a birth certificate.
- (6) Where a team declaration is required for an event, this entry shall be verified by an authorised official of the Club on whose behalf the entry is made, and the Club shall be responsible for the accuracy of the information given by such official. Any affiliated Club making a false entry shall be dealt with for misconduct. (as defined in Rule T7 S1).

- (7) Participation in a competition under UKA Rules shall only be valid if the stipulated entry fee has been received.
- (8) All advertisements, and programmes (whether printed or electronic) shall state that the meeting or competition is being held “Under UKA Rules”.
- (9) Competition Providers of an Open Team event must declare in advance which team awards are included within the event or race and the manner in which they will be decided. In the case of a relay race the distance of each section and the order in which sections are to be run must be similarly declared.

**RULE T4 (142) S 2 UKA SUPPLEMENT  
ROAD RACES**

- (1) Any Competition Provider applying for a Road Race Licence must set a final closing date for the normal acceptance of entries and may determine a limit to the maximum number of entries that will be accepted. Any competitor entering after this date may, if the entry is accepted, be charged an additional late entry fee if the Competition Provider so wishes.
- (2) A Competition Provider must exhibit a listing, or provide a programme, showing all entries received by the published closing date. A list of all entrants, including any late entrants, must be provided to the Referee on request before the start of the race.
- (3) A runner whose entry is accepted after the published closing date may, at the discretion of the Competition Provider:
  - (i) not be eligible for any individual prize.
  - (ii) not be eligible as a scoring team member in a team race.
- (4) Runners who compete in any road race which does not have a UKA licence may thereby render themselves liable to suspension. This does not apply in the case of fun runs.

**RULE T4 (142) S 3 UKA SUPPLEMENT  
FELL, HILL AND MOUNTAIN RUNNING**

No runner may take part in any race without having entered the race in accordance with the current appropriate Safety requirements.

**RULE T4 (142) S 4 UKA SUPPLEMENT  
TRAIL RACES**

The Competition Provider may accept entries after the published closing date, but decide such competitors are not eligible for individual prizes and/or are not eligible to be scoring team members. These limitations should be made clear at the time of accepting the entry.

**RULE 5 CLOTHING, SHOES AND ATHLETE BIBS**

**CLOTHING**

1. In all events, athletes must wear clothing which is clean, and designed and worn so as not to be objectionable. The clothing must be made of a material which is non-transparent even if wet. Athletes must not wear clothing which could impede the view of the Judges. At all competitions under paragraphs 1.1, 1.2, 1.3, 1.6 and 1.7 of the International Competition definition, and when representing their Member Federation under paragraphs 1.4 and 1.8 of the International Competition definition, athletes shall participate in the uniform clothing approved by their Member Federation. The Victory Ceremony and any lap of honour are considered part of the competition for this purpose.

**SHOES**

2. Athletes may compete barefoot or with footwear on one or both feet. The purpose of shoes for competition is to give protection and stability to the feet and a firm grip on the ground. Such shoes, however, must not be constructed so as to give athletes any unfair assistance or advantage. Any type of shoe used must be reasonably available to all in the spirit of the universality of athletics.

*Note (i): Adapting a shoe to suit the characteristic of a particular athlete's foot is permitted if made in accordance with the general principles of these Rules.*

*Note (ii): Where evidence is provided to World Athletics that a type of shoe being used in competition does not comply with the Rules or the spirit of them, it may refer the shoe for study and if there is non-compliance may prohibit such shoes from being used in competition.*

### **NUMBER OF SPIKES**

3. The sole and heel of the shoes shall be so constructed as to provide for the use of up to 11 spikes. Any number of spikes up to 11 may be used but the number of spike positions shall not exceed 11.

### **DIMENSIONS OF SPIKES**

4. That part of each spike which projects from the sole or the heel shall not exceed 9mm except in the High Jump and Javelin Throw, where it shall not exceed 12mm. The spike must be so constructed that it will, at least for the half of its length closest to the tip, fit through a square sided 4mm gauge. If the track manufacturer or the stadium operator mandates a lesser maximum, this shall be applied.

*Note (i): The surface must be suitable for accepting the spikes permitted under this Rule.*

*Note (ii): For Cross Country competitions, the specific regulations or the Technical Delegates may allow an increased length of the sizes of the spikes of the shoes depending on the surface.*

### **THE SOLE AND THE HEEL**

5. The sole and/or heel may have grooves, ridges, indentations or protuberances, provided these features are constructed of the same or similar material to the basic sole itself.  
In the High Jump and Long Jump, the sole shall have a maximum thickness of 13mm and the heel in High Jump shall have a maximum thickness of 19mm. In all other events the sole and/or heel may be of any thickness.

*Note: The thickness of the sole and heel shall be measured as the distance between the inside top side and the outside under side,*

*including the above-mentioned features and including any kind or form of loose inner sole.*

### **INSERTS AND ADDITIONS TO THE SHOE**

6. Athletes may not use any appliance, either inside or outside the shoe, which will have the effect of increasing the thickness of the sole above the permitted maximum, or which can give the wearer any advantage which they would not obtain from the type of shoe described in the previous paragraphs.

### **ATHLETE BIBS**

7. Every athlete shall be provided with two bibs which, during the competition, shall be worn visibly on the front of the torso and back, except in the Jumping Events, where one bib may be worn on the front of the torso or back only. Either the athletes' names or other suitable identification will be allowed instead of numbers on any or all of the bibs. If numbers are used, they shall correspond with the number allocated to the athlete on the start list or in the programme. If track suits are worn during the competition, bibs shall be worn on the track suit in a similar manner.
8. No athlete shall be allowed to take part in any competition without displaying the appropriate bib(s) and/or identification.
9. These bibs must be worn as issued and may not be cut, folded or obscured in any way. In running or walking events of 10,000 metres and longer, the bibs may be perforated to assist the circulation of air, but the perforation must not be made on any of the lettering or numerals which appear on them.
10. Where a Photo Finish System is in operation, the Organisers may require athletes to wear additional number identification of an adhesive type on the side of their shorts or lower body.
11. If an athlete does not follow this Rule in any way and:
  - 11.1. refuses the direction of the relevant Referee to comply; or
  - 11.2. participates in the competition, they shall be disqualified.

Rule 5.1 of the Technical Rules should be interpreted widely in terms of what "might impede the view of the judges", including athletes wearing their hair in a particular way.



Rule 5.11 of the Technical Rules prescribes the sanction if any aspect of Rule 5 of the Technical Rules is not followed. It is expected however that where possible the relevant officials should request and encourage the athlete to comply and to advise them of the consequence if they do not. But where an athlete does not follow an aspect of the Rule during competition and it is not practical for an official to request compliance that disqualification may, or will, follow.

It is a responsibility of the Starters Assistants and Umpires (for Track and Out of Stadium Events) and the Judges (for Field Events) to be vigilant on these matters and report any apparent breaches to the relevant Referee.

### **RULE T5 (143) S 1 UKA SUPPLEMENT CLOTHING**

- (1) All advertising and sponsorship contracts (other than the sponsorship of events) with any Club or individual athlete under the jurisdiction of UKA must be registered with UKA.
- (2) For all competitions held under World Athletics Rules clothing (deemed to include track suits and any other equipment) must comply with these rules and associated World Athletics Regulations.
  - (i) Should athletes or clubs wish to wear an identification of a personal sponsor in UKA events then the identification may appear only once and must be a maximum of 80 square cm, with any lettering maximum height of 8cm. This is subject to World Athletics Rule G8 (2) & T5 (1) and the requirement that the specific design of the advertising material to be used, together with the name of the sponsor(s) shall be submitted by the Club to their National Association for prior approval and registration. For the avoidance of doubt this need for approval by National Associations does not apply to “branded” clothing and equipment available on the open market provided by bona fide suppliers of athletic clothing and equipment.

*NOTE: World Athletics Advertising Regulation 5.2 allows a manufacturer’s logo to be no more than 40 square cm with a maximum height of 5cm. In any competitions held under World Athletics rules, or where the licence conditions require World*

*Athletics regulation compliance, an athlete must have World Athletics compliant kit to wear in those competitions.*

- (3) In team or relay races all competitors must wear registered vests of the same design and colour of the team they are representing unless the Referee has given permission for a change to be made.

*NOTE 1: This Rule does not preclude the possibility of clothing being different in style between participants in the same team e.g. vests of different length, cut of sleeve or collar etc. Any team clothing should, though, still broadly correspond in colour and design notwithstanding these differences.*

*NOTE 2: Clubs are permitted to have two sets of colours registered at any one time.*

- (4) In individual English County, English Area, Scottish District, Welsh Regional and National Championships, (but excluding Road Running) athletes must wear the vest of their first-claim affiliated Club, their County, Area, District, Regional or National vest, or any other Representative vest approved by UKA. The affiliated Club concerned must be the one which in terms of Rule G2 S2(4) caters for that particular discipline of athletics.

*NOTE: In exceptional circumstances the Referee may grant permission for an alternative vest to be worn.*

- (5) Except as is allowed for in this rule, competitors are not allowed to take into an arena or course any form of advertising material, nor to display on their person any such advertising other than:
- (i) the accepted name of their affiliated Club in lettering which should not exceed 8cm in height. In the case of County vests, the lettering indicating the name shall not exceed 8cm in height.
  - (ii) a single Trademark of the manufacturer of the clothing they are wearing which may appear on the upper body attire. This Mark must not exceed 30 square cm, with the lettering maximum height of 5cm and the total logo maximum height of 6cm. This Mark may appear twice, on the front and the back of upper body attire. On lower body attire the logo shall not exceed 20 square cm with maximum height of 4cm and may only appear once.

*NOTE: The printing of website addresses on Club vests is not permitted.*

## **(6) Track & Field**

### **Footwear**

*NOTE: For non-synthetic surfaces the maximum length of spike shall be 25mm and the maximum diameter 4mm.*

## **(7) Race Walking**

In order that judges may apply the Rules relating to walking, competitors' knees shall normally be bare. If garments are worn that cover the knee, the Referee's permission must be obtained before the commencement of the race, and the Chief Judge notified. Any competitor starting without permission will be disqualified by the Referee.

## **RULE 5 (143) S 2 UKA SUPPLEMENT ATHLETE BIBS**

(1) Every athlete shall be provided with at least one bib which shall normally be worn on the breast and show a suitable identification number or name.

### **(2) Road Races**

- (i) There should be provision for medical information and contact details on the reverse of the bib for prior completion by the athlete.
- (ii) In Road Relays every athlete must wear the supplied bib(s), which must serve to identify the team and should also identify the stage that the athlete is running.
- (iii) Numbers are issued to the individual athlete completing the application form except with the specific authority of the Competition Provider. Athletes who receive transferred numbers without permission will be disqualified from the race. Both runners will be subject to disciplinary action by the appropriate National Association.
- (iv) A runner must retire immediately if ordered to do so by a medical officer of the race.

- (v) Runners who retire from a race must not remove their bib until they have reported to an official as having retired from the race.

## **RULE 6 ASSISTANCE TO ATHLETES**

### **MEDICAL EXAMINATION AND ASSISTANCE**

1. Medical examination / treatment and/or physiotherapy may be provided either on the competition area itself by the official medical staff appointed by the Organisers and identified by armbands, vests or similar distinctive apparel or in designated medical treatment areas outside the competition area by accredited team medical personnel specifically approved by the Medical or Technical Delegate(s) for the purpose. In neither case shall the intervention delay the conduct of the competition or an athlete's trial in the designated order. Such attendance or assistance by any other person, whether immediately before competition, once athletes have left the Call Room or during competition, is assistance.

*Note: The competition area, which normally also has a physical barrier, is defined for this purpose as the area where the competition is being staged and which has an access restricted to the competing athletes and personnel authorised in accordance with the relevant rules and regulations.*

2. Any athlete giving or receiving assistance from within the competition area during an event (including under Rules 17.14, 17.15, 54.10 and 55.8 of the Technical Rules) shall be warned by the Referee and advised that, if there is any repetition, they will be disqualified from that event.

*Note: In cases under Rule 6.3.1 of the Technical Rules, disqualification may be made without warning.*

### **ASSISTANCE NOT ALLOWED**

3. For the purpose of this Rule, the following examples shall be considered assistance, and are therefore not allowed:
  - 3.1. Pacing in races by persons not participating in the same race, by athletes lapped or about to be lapped or by any kind of technical device (other than those permitted under Rule 6.4.4 of the Technical Rules).

- 3.2. Possession or use of video recorders, radios, CD, radio transmitters, mobile phone or similar devices in the competition area.
- 3.3. Except for shoes complying with Rule 5 of the Technical Rules, the use of any technology or appliance that provides the user with an advantage which they would not have obtained using the equipment specified in, or permitted by, the Rules.
- 3.4. The use of any mechanical aid, unless the athlete can establish on the balance of probabilities that the use of an aid would not provide them with an overall competitive advantage over an athlete not using such aid.
- 3.5. Provision of advice or other support by any official of the competition not related to or required by their specific role in the competition at the time (e.g., coaching advice, indication of the take-off point in a jumping event except to indicate a failure in Horizontal Jumps, time or distance gaps in a race etc.).
- 3.6. Receiving physical support from another athlete (other than helping to recover to a standing position) that assists in making forward progression in a race.

#### **ASSISTANCE ALLOWED**

4. For the purpose of this Rule, the following shall not be considered assistance, and are therefore allowed:
  - 4.1. Communication between the athletes and their coaches not placed in the competition area. In order to facilitate this communication and not to disturb the staging of the competition, a place in the stands, close to the competition area of each Field Event, should be reserved to the athletes' coaches.

*Note: Coaches and other persons otherwise complying with Rules 54.10 and 55.8 of the Technical Rules may communicate with their athlete(s).*
  - 4.2. Medical examination/treatment and/or physiotherapy necessary to enable an athlete to participate or continue

- participation once on the competition area under Rule 6.1 of the Technical Rules.
- 4.3. Any kind of personal safeguard (e.g. bandage, tape, belt, support, wrist cooler, breathing aid etc.) for protection and/or medical purposes. The Referee, in conjunction with the Medical Delegate, shall have the authority to verify any case should the Referee judge that to be desirable. (See also Rules 32.4 and 32.5 of the Technical Rules.)
  - 4.4. Heart rate or speed distance monitors or stride sensors or similar devices carried or worn personally by athletes during an event, provided that such device cannot be used to communicate with any other person.
  - 4.5. Viewing by athletes competing in Field Events, of images of previous trial(s), recorded on their behalf by persons not placed in the competition area (see Note to Rule 6.1 of the Technical Rules). The viewing device or images taken from it must not be taken into the competition area.
  - 4.6. Hats, gloves, shoes, items of clothing provided to athletes at official stations or when otherwise approved by the relevant Referee.
  - 4.7. Receiving physical support from an official or other person designated by the organisers to recover to a standing position or to access medical assistance.
  - 4.8. Electronic lights or similar appliance indicating progressive times during a race, including of a relevant record.

Rule 6 of the Technical Rules has been the subject of constant change in recent years to reflect the way in which athletics is conducted, to respect the role of coaches, to manage innovation and new products, etc. World Athletics will continue to respond to new products and trends as soon as they become common place during events and competitions.

Changes to these rules are designed to facilitate the athletes' participation in the competition as much as possible and to reduce unnecessary conflict between athletes/coaches and the officials. Each of these rules should be interpreted in this light whilst always ensuring the competition is conducted fairly to all.

Rule 6.3.5 of the Technical Rules however makes it clear that the officials should not assist any athlete beyond what is required of their role – and specifically states as an example that officials should not provide details of the take-off position in jumping events, other than for the purpose of indicating the point of “impact” in a foul jump in Horizontal Jumps.

## **RULE 7 EFFECT OF DISQUALIFICATION**

### **Disqualification resulting from an infringement of a Technical Rule (other than Rule 18.5 of the Competition Rules and Rule 16.5 of the Technical Rules)**

1. If an athlete is disqualified in an event for an infringement of a Technical Rule (except under Rule 18.5 of the Competition Rules or Rule 16.5 of the Technical Rules) any performance accomplished in the same round of that event up to the time of the disqualification shall not be valid. However, performances accomplished in a previous round of that event shall remain valid. Such disqualification from an event shall not prevent an athlete from taking part in any further event in that competition.

### **Disqualification resulting from exclusion under Rule 18.5 of the Competition Rules (including under Rule 16.5 of the Technical Rules)**

2. If an athlete is excluded from competition under Rule 18.5 of the Competition Rules, they shall be disqualified from that event. If the athlete's second warning occurs in a different event, they shall be disqualified only from the second event. Any performance accomplished in the same round of that event up to the time of the disqualification shall not be valid. However, performances accomplished in a previous round of that event, other previous events or previous individual events of a Combined Event shall remain valid. Such disqualification shall prevent an athlete from taking part in all further events, (including individual events of a Combined Event, other events in which they are simultaneously participating and relays) in that competition.
3. If a relay team is excluded from competition under Rule 18.5 of the Competition Rules, it shall be disqualified from that event. Performances accomplished in a previous round of that event shall

remain valid. Such disqualification shall not prevent any athlete from that team taking part in all further events (including individual events of a Combined Event, other events in which they are simultaneously participating and relays) in that competition.

4. If the offence is considered serious, the Competition Director shall report it to the relevant governing body for consideration of further disciplinary action.

### **RULE T7 (145) S 1 UKA SUPPLEMENT MISCONDUCT**

- (1) Any individual athlete or official of an affiliated Club making a false entry for competition shall be dealt with by the appropriate National Association for misconduct.
- (2) Any competitor (or other person) interfering or attempting to interfere with the decision of an event official, or indulging in unfair practices or misbehaviour, including the use of offensive or abusive language shall, at the discretion of the Referee, be disqualified from the competition and, if deemed necessary, reported to the appropriate National Association for further action. Performances achieved in the competition from which they were disqualified shall not stand.

*NOTE: The use of offensive language audible to others should normally attract a warning from the Referee, but, if targeted at an official, should immediately attract a disqualification.*

- (3) Athletes or officials who breach the Rules of Competition or conduct themselves in a manner which may bring discredit to the sport of athletics may be reported to the appropriate National Association to take such action as it deems necessary.

### **RULE 8 PROTESTS AND APPEALS**

1. Protests concerning the status of an athlete to participate in a competition must be made, prior to the commencement of such competition, to the Technical Delegate(s). Once the Technical Delegate(s) make(s) a decision, there shall be a right of appeal to the Jury of Appeal. If the matter cannot be settled satisfactorily prior to



the competition, the athlete shall be allowed to compete "under protest" and the matter be referred to the relevant governing body.

2. Protests concerning the result or conduct of an event shall be made within 30 minutes of the official announcement of the result of that event.

The Organisers of the competition shall be responsible for ensuring that the time of the announcement of all results is recorded.

3. Any protest shall be made orally to the Referee by an athlete, by someone acting on their behalf or by an official representative of a team. Such person or team may protest only if they are competing in the same round of the event to which the protest (or subsequent appeal) relates (or are competing in a competition in which a team points score is being conducted). To arrive at a fair decision, the Referee should consider any available evidence which they think necessary, including a film or picture produced by an official video recorder, or any other available video evidence. The Referee may decide on the protest or may refer the matter to the Jury of Appeal. If the Referee makes a decision, there shall be a right of appeal to the Jury. Where the Referee is not accessible or available, the protest should be made to them through the Technical Information Centre.

4. In a Track Event,

- 4.1. if an athlete makes an immediate oral protest against having been charged with a false start, a Track Referee may, if they are in any doubt, allow the athlete to compete "under protest" in order to preserve the rights of all concerned. Competing "under protest" shall not be allowed if the false start was indicated by a World Athletics certified Start Information System, unless for any reason the Referee determines that the information provided by the System is obviously inaccurate.

- 4.2. a protest may be based on the failure of the Starter to recall a false start or, under Rule 16.5 of the Technical Rules, to abort a start. The protest may be made only by, or on behalf of, an athlete who has completed the race. If the protest is upheld, any athlete who committed the false start or whose conduct should have led to the start being aborted, and who was subject to warning or disqualification according to Rules 16.5, 16.7, 16.8 or 39.8.3 of the Technical Rules, shall be

warned or disqualified. Whether or not there may be any warning or disqualification, the Referee shall have the authority to declare the event or part of the event void and that it or part of it shall be held again if in their opinion justice demands it.

*Note: The right of protest and appeal in Rule 8.4.2 of the Technical Rules shall apply whether or not a Start Information System is used.*

43. if a protest or appeal is based on an athlete's incorrect exclusion from an event due to a false start and it is upheld after the completion of the race, then the athlete should be afforded the opportunity to run on their own to record a time in the event and consequently, if applicable, to be advanced to subsequent rounds. No athlete should be advanced to a subsequent round without competing in all rounds unless the Referee or Jury of Appeal determines otherwise in the particular circumstances of the case, e.g. the shortness of time before the next round or the length of the race.

*Note: This Rule may also be applied by the Referee, the Jury of Appeal in other circumstances where it is deemed appropriate (see Rule 17.2 of the Technical Rules).*

44. when a protest is made by or on behalf of an athlete or team which did not finish a race, the Referee must first ascertain whether the athlete or team was or should have been disqualified for a breach of the Rules unrelated to the matter raised in the protest. Should that be the case the protest shall be dismissed.

When the Start Referee decides on an immediate oral protest made by an athlete for being charged with a false start, they have to consider all the available data and in case of only a reasonable possibility that the athlete's protest may be valid, they should allow the athlete to compete under protest. After the race, a final decision must be taken by the Referee, a decision that may be subject of an appeal to the Jury. But to be clear, the Referee should not allow an athlete to compete under protest

if the false start has been detected by a Start Information System that appears to be working properly or in cases where it is very clear by visual observation that the athlete has committed a false start and there is no valid reason to allow the protest.

These rules not only apply where a Starter failed to recall a false start but where also a Starter failed to correctly “abort” a start. In both cases the Referee must consider all factors involved in the particular case and must decide if the race (or part of it) has to be re-held.

Giving two examples of extreme situations, it will not be logical or necessary to re-run a Marathon race in a case where an athlete who finishes was responsible for a non-recalled false start. But the same will probably not be the case in a sprint event where an athlete was responsible for a non-recalled false start as this may have affected the start and subsequent race of other athletes.

On the other hand, if for example in a preliminary round, or perhaps even more so in a race within a Combined Event, it was clear that only one or some athletes were disadvantaged by a failure to recall a false start or to abort a start, a Referee could decide that only those athletes be given the opportunity to run again – and if so under what conditions.

Rule 8.4.3 of the Technical Rules covers the situation in which an athlete is wrongly given a false start and excluded from a race.

5. In a Field Event, if an athlete makes an immediate oral protest against having a trial judged as a failure, the Referee of the event may, if they are in any doubt, order that the trial be measured and the result recorded, in order to preserve the rights of all concerned. If the protested trial occurred:
  - 5.1 during the first three rounds of trials of a horizontal Field Event in which more than eight athletes are competing, and the athlete would advance to any subsequent rounds of trials only if the protest or subsequent appeal was upheld; or
  - 5.2 in a vertical Field Event, where the athlete would advance to a higher height only if the protest or subsequent appeal is upheld, the Referee may, if they are in any doubt, allow the athlete to continue competing “under protest” to preserve the rights of all concerned.

In cases where the Referee is sure that the decision of the Judges is correct, particularly by their own observation or advice received from a Video Referee, the athlete should not be allowed to continue.

But when considering whether to order the measurement of a trial which is the subject of an immediate oral protest the Referee should:

- a not do so in cases where there was a clear breach of the Rules, for example in the long jump a clear mark made in the plasticine by the athlete in question or in a throwing event where the implement has clearly landed outside the sector;
- b always do so (and immediately so as to not delay the competition) in cases where there is any doubt.

The good operation of this Rule means that the Judge with the spike or prism should always mark the point of landing (except in throwing events where the implement clearly lands outside the sector) even when they see a red flag. Apart from the possibility that the athlete may make an immediate oral protest, it is also possible that the Judge with the flags may have incorrectly or accidentally raised the wrong one.

- 6 The protested performance of the athlete and any other performance achieved by them while competing “under protest” will become valid only if a subsequent decision to that effect is made by the Referee or an appeal to the Jury of Appeal is made and it is upheld. In Field Events where, as a result of an athlete competing “under protest”, another athlete is allowed to continue in the competition when they would otherwise not have done so, such athlete’s performances and eventual results will remain valid irrespective of whether the “under protest” athlete’s immediate oral protest is successful.

Rule 8.6 of the Technical Rules applies to all events, not only to Field Events.

7. An appeal to the Jury of Appeal must be made within 30 minutes:
  - 7.1 of the official announcement of the amended result of an event arising from the decision made by the Referee; or
  - 7.2 of the advice being given to those making the protest, where there is no amendment of any result.

It shall be in writing, signed by the athlete, by someone acting on their behalf or by an official representative of a team and shall be accompanied by a deposit of USD 100, or its equivalent, which will be forfeited if the appeal is not allowed. Such athlete or team may appeal only if they are competing in the same round of the event to which the appeal relates (or are competing in a competition on which a team points score is being conducted).

*Note: The relevant Referee shall, after their decision on a protest, immediately inform the TIC of the time of the decision. If the Referee was unable to communicate this orally to the relevant team(s) /athlete (s), the official time of the announcement will be that of posting of the amended result or of the decision at the TIC.*

8. The Jury of Appeal shall consult all relevant persons, including the relevant Referee (except when their decision is to be fully maintained by the Jury of Appeal). If the Jury of Appeal is in doubt, other available evidence may be considered. If such evidence, including any available video evidence, is not conclusive, the decision of the Referee or the Chief Race Walking Judge shall be upheld.
9. The Jury of Appeal may reconsider a decision if new conclusive evidence is presented, provided the new decision is still applicable. Normally, such re-consideration may be undertaken only prior to the Victory Ceremony for the applicable event, unless the relevant governing body determines that circumstances justify otherwise.

**In certain circumstances, the Judges (Rule 19.2 of the Competition Rules), the Referee (Rule 18.6 of the Competition Rules) and the Jury (Rule 8.9) can each reconsider a decision made by them – if it is still applicable and practical to do so.**

10. Decisions involving points which are not covered by the Rules shall be reported subsequently by the Chairman of the Jury of Appeal to the Chief Executive Officer of World Athletics.
11. The decision of the Jury of Appeal (or of the Referee in the absence of a Jury of Appeal or if no appeal to the Jury is made) shall be final and there shall be no further right of appeal, including to CAS.

**RULE T8 (146) S 1 UKA SUPPLEMENT  
PROTESTS AND APPEALS**

For meetings where there is no Jury of Appeal and / or Technical Information Centre the following provisions shall apply:

**(1) Qualification to compete.**

**(i) Protest**

- (a) Any protest or objection against the qualification to compete, or the statements in the entry form of another competitor or Club, shall be made to the appropriate Referee as early as possible and where practicable such protest or objection should be made before the commencement of the competition. Where the protest relates to competitors' eligibility to compete, by means of registration or equivalent, the referee may refer the matter to the Competition Provider or National Association to determine. They may decide the protest or objection at the event or after investigation, such investigations should be concluded within one week of the competition date. In the event of a protest or objection being lodged against a successful competitor or team, the prize or prizes shall be withheld until the protest or objection has been disposed of in a manner provided for in this Rule.
- (b) To assist in the compliance of athlete registration and thereby eligibility to compete the National Associations should undertake checks on competition results to ensure that athletes are registered in compliance with "World Athletics Rule G2 UKA Supplement 1(1) Eligible athletes". Such checks will be undertaken within one week of the competition. Following the conclusion of their investigations, if the National Association decides that the athlete is ineligible, they must forthwith notify the Competition Provider which should then adjust the results of its competition in accordance with its rules.
- (c) In the event of a successful protest under (1)(i)(a) and (b) above the Competition Provider should re-score the

competition in accordance with the rules of the competition.

(ii) Appeal

- (a) In the event that the protestor has not accepted the decision reached after investigation they or an authorised official shall take action by objecting directly to the National Association in writing within one week of the decision.
- (b) In the event of an Appeal against a decision by a National Association solely with regard to registration, the National Association will set up an Independent Panel to determine the Appeal. Such determination should be made within one week of receipt of the Appeal.

**(2) Technical Rules, Conduct or Placing**

- (i) Any protest or objection by a competitor or team against the conduct or placing of another competitor or team in any competition, or relating to any matter which may develop during the event, shall be made to the appropriate Referee immediately after that event or competition, or immediately after the results are published.
- (ii) Every protest or objection lodged under (2)(i) may be made verbally by the individual competitor or by a member of the protesting Club.
- (iii) The Referee shall decide any protest or objection made under (2)(i) having reviewed all the relevant information, on the ground, or after investigation. The Referee's decision shall be final.
- (iv) Where protests are made in respect of the Start, the Starter's decision is final.
- (v) Cross Country and Road Races: If the results are not available at the conclusion of the event, then such a protest may be made at any time up until one week after the publication of the results. In such cases the protest should be made to the Referee through the Competition Provider. If, as a result of a protest under (2)(i) or (2)(ii) above, a runner is disqualified or the race result otherwise altered, the Referee shall inform the Competition Provider of that amended result, in writing, within one week. The Competition Provider must then inform the individual(s) affected by the decision and, if required, take steps to recover

prizes or awards made to the athlete(s). The Referee's decision shall be final.

- (vi) **Fell, Hill and Mountain Running:** If the results are not available at the conclusion of the event, then such a protest may be made at any time up until one week after the publication of the results. In such cases the protest should be made to the Competition Provider and/or the Referee. If, as a result of a protest under (2)(i) or (2)(ii) above, a runner is disqualified or the race result otherwise altered, the Competition Provider must then inform the individual(s) affected by the decision and, if required, take steps to recover prizes or awards made to the athlete(s). The Competition Provider's / Referee's decision shall be final.

### **(3) Misconduct relating to competition**

In the event of a matter of misconduct being reported to a National Association in accordance with rule T7 the National Association shall form an Investigatory Panel to review the matter and determine what penalties are enforced in accordance with Rule T7. They must have completed their investigation within a month of its referral to them.

### **(4) Further appeal to UKA in relation to competition matters**

Any competitor, team or Club may appeal against the decision of a National Association. Notice of Appeal must be sent to UKA within 14 days of receipt of such decision and must be accompanied by a deposit of £50, which will be refundable at the discretion of UKA. In addition, the board of UKA, may at its discretion, refer any decision taken by a National Association, and after consultation with the National Association, to an Independent Appeals Panel. Any other disciplinary matters that are not related to competition must be dealt with by policies and procedures outside the Competition Rule Book. The Appeal will be determined in accordance with the procedures established by UKA.

Without prejudice to the foregoing, where any competitor, team or club wishes to appeal any decision reached under (1) and (3) above it may seek resolution in accordance with the Appeal Procedure established by UKA. Any application for such an appeal must be received within 2 weeks of the date of the event or of the decision being contested or from a related decision made by a National Governing Body being published. UKA shall convene a Hearing within 4 weeks of receipt of the Notice of



Appeal and shall notify all parties deemed to be involved in the Appeal. No new evidence will be accepted by UKA that has not been submitted previously to the Associations concerned. The hearing shall be conducted by an independent panel of three persons for that purpose. No member of the panel shall have any connection with any of the parties involved in the dispute or any vested interest in the outcome. The decision of the panel shall be final in accordance with UKA's jurisdiction. Appeals in accordance with this provision are limited to those relating to Qualification to Compete and Misconduct only.

**For the avoidance of doubt** Appeals concerning any matters not relating to Competition are matters solely within the jurisdiction of National Associations and UKA and will be dealt with in accordance with their published procedures.

## **RULE 9 MIXED COMPETITION**

1. Universal competitions such as relays or other team events in which men and women compete together or events in which men and women compete for a single classification are permitted in accordance with the applicable regulations of the relevant body.
2. Other than under Rule 9.1 for all other competitions held completely in the stadium, mixed events between male and female participants shall not normally be permitted.

However, the following may be permitted in all competitions except those held under paragraphs 1.1 to 1.3 and 1.6 of the International Competition definition. In the case of competitions held under paragraphs 1.4, 1.5 and 1.7 to 1.10 of the International Competition definition such competition shall always be allowed in Field Events and in events per Rule 9.2.1 of the Technical Rules, if specifically permitted by the relevant Area Association:

- 21 mixed stadium competition in races of 5000m or longer but it is permitted only when there are insufficient athletes of one or both sexes competing to justify the conduct of separate races. The sex of each athlete shall be shown in the result. Such races shall not, in any case, be conducted so as to allow athletes of one sex to be paced or assisted by athletes of another sex.

- 22 Field Events for men and women may be conducted simultaneously at one or more event sites. Separate result cards shall be used and results declared for each sex. Each round of trials of such events may be conducted either by calling all athletes of one sex followed by the other or by alternating them. For the purposes of Rule 25.17 of the Technical Rules, all athletes shall be regarded as if they were of the same sex. Where Vertical Jumps are conducted on a single event site, Rules 26 to 28 must be strictly applied, including that the bar must continue to be raised in accordance with a single set of previously announced increments for the entire competition.

The intent of Rule 9.2.1 of the Technical Rules is to facilitate the conduct of races of 5000m or longer, when small numbers of athletes of one or both sexes are entered in the case of longer events (i.e. a track Race Walk of 10,000m or more), where timetabling constraints make it difficult to program separate races. The intent of the Rule is not to provide opportunity for women to compete in races against men to achieve potentially better performance conditions.

To be clear, mixed competition in Field Events and in races of 5000m or longer is:

- a. permitted in all national competitions, subject only to the rules of the applicable federation. [No additional permission from an Area Association is required];
- b. permitted in a competitions held under paragraphs 1.9 and 1.10 of the International Competition definition if specifically permitted by the relevant Area Association;
- c. not permitted in a competition held under paragraphs 1.1 to 1.8 of the International Competition definition unless in the case of Field Events the applicable regulations for the competition so provide.

There are also restrictions on the recognition of World Records in mixed competitions – see Rules 31.1 (with reference to track races of 5000m and longer) and 32 (with reference to women's road races) of the Competition Rules. Rule 32 of the Competition Rules Note (ii) provides guidance on how a women only race can be achieved (enabling a women

only record to be set) in a situation where both men and women are or might be competing.

[See also Rules 25.2 and 25.3 of the Competition Rules]

### **RULE T9 (147) S 1 UKA SUPPLEMENT MIXED COMPETITION**

For competitions held entirely within the stadium, mixed events between male and female athletes shall be permitted in field events and mixed graded track races shall be permitted for all age groups, subject to any limitations regarding distances that may apply.

*Note: Performances achieved in mixed track races will not be valid as qualifying times for major events and Championships, nor National Records identified in Rule C35 S1.*

Mixed road walking competitions between male and female participants of the same age group shall be permitted for Club, Inter-Club and open events. Mixed competitions may also be held in National or UKA Championships but only where the number of participants make it impracticable to stage two separate races

### **RULE 10 SURVEYING AND MEASUREMENTS**

1. The accuracy of the markings and installations for athletics facilities under Rules 2 and 11.2 of the Technical Rules shall be checked by an appropriately qualified surveyor who shall furnish appropriate certificates together with details of any check measurements made to the relevant body and/or the facility owner or operator. They shall be given full access to stadium plans and drawings and the latest measurement report for the purpose of this verification.
2. For Track and Field Events in competitions under paragraphs 1.1, 1.2, 1.3 and 1.6 of the International Competition definition, all measurements shall be made with a calibrated steel tape or bar or with a scientific measuring device. The steel tape, bar or scientific measuring device shall be manufactured and calibrated according to international standards. The accuracy of the measuring equipment used in the competition shall have been verified by an appropriate organisation accredited by the national measurement authority.

At competitions other than those held under paragraphs 1.1, 1.2, 1.3 and 1.6 of the International Competition definition, fibreglass tapes may also be used.

*Note: Concerning acceptance of Records, see Rule 31.17.1 of the Competition Rules.*

## **RULE 11 VALIDITY OF PERFORMANCES**

1. No performance accomplished by an athlete will be valid unless it is accomplished during an official competition organised in conformity with the Rules.
2. Performances in events normally conducted in the stadium, made outside traditional athletics facilities (such as those held in town squares, other sporting facilities, beaches, etc.) or on temporary facilities built within a stadium shall be valid and recognised for all purposes, if they are made subject to all of the following conditions:
  - 2.1 the relevant governing body as provided in Rules 2 to 3 of the Competition Rules has issued a permit for the event;
  - 2.2 a qualified panel of National Technical Officials are appointed to and officiate at the event;
  - 2.3 where applicable, equipment and implements in conformity with the Rules are used; and
  - 2.4 the event is conducted in a competition area or facility in conformity with the Rules and in respect of which a survey has been made in accordance with Rule 10 before the event and, where possible, on the day of the event.

*Note: The current standard forms required to be used for reporting on the conformity of the competition area or facility are available from the World Athletics Office or may be downloaded from the World Athletics website.*

When a competition described in Rule 11.2 of the Technical Rules is held over more than one day, the survey should be made on the day of the first event. In either case if the surveyor can be satisfied that there will be no movement of alteration to the facilities being surveyed, the survey may be completed up to two days prior to the day of the first event.

3. Performances made in accordance with these Rules in Qualification Rounds, in deciding ties in High Jump and Pole Vault, in any event or part of an event which is subsequently decreed void under the provisions of Rule 18.7 of the Competition Rules, or Rules 8.4.2, 17.2 or 25.20 of the Technical Rules, in Race Walking events in which Rule 54.7.3 is applied and the athlete is not disqualified or in individual events in Combined Events competitions, regardless of whether or not the athlete completes the whole Combined Events competition, will normally be regarded as valid for purposes such as statistics, records, rankings and the achievement of entry standards.

World Athletics has exceptionally determined that solely for the purpose of determining whether an athlete has achieved the entry standard for a Combined Events competition:

“The conditions shall have been complied with in each of the individual events, except that, in events where wind velocity is measured, at least one of the following conditions shall be satisfied:

- a. The velocity in any individual event shall not exceed plus 4 metres per second.
- b. The average velocity (based on the algebraic sum of the wind velocities, as measured for each individual event, divided by the number of such events) shall not exceed plus 2 metres per second.”

### **RULE 12 VIDEO RECORDING**

In competitions held under paragraphs 1.1, 1.2 and 1.3 of the International Competition definition and, whenever possible, in other competitions, an official video recording of all events to the satisfaction of the Technical Delegate(s) shall be made. It should be sufficient to support the role of the Video Referee when appointed and in other situations to demonstrate the accuracy of performances and any violation of the Rules.

Specific information is provided in the Video Recording and Video Referee Guidelines, which may be downloaded from the World Athletics website.

The appointment at any competition of a Video Referee will significantly affect the practical oversight of many aspects of those competitions at which sufficient video collection and replay systems are available.

The Video Referee will generally be able to act proactively in respect of the track events (e.g. the start, running inside the lane line around the curve, jostling and obstruction, breaking from lanes too early, relay changeovers). If the number of cameras and equipment is sufficient to play a similar role for some or all of the Field Events, they can undertake a similar role, but usually in a more reactive fashion when the on-field Referee requests further examination or review of a specific incident.

In the case of the Track Events, the Video Referee will observe the races on one or more screens in the video room and then based on either their own observations or upon referral from a Referee or Chief Umpire in the competition area, examine one or more particular issues by looking at any replayed footage that might be available. If it is clear as a result that there has been an infringement of the Rules, then they should take the appropriate decision and convey it to the Track Referee and the Chief Photo Finish Judge. Similarly, if an Umpire or trackside Referee has reported a potential infringement, it should be checked by the Video Referee and the appropriate advice provided and decision taken.

In addition, official video footage will as in the past continue to be used to assist in dealing with protests and appeals.

It is becoming common for experienced companies to provide an existing service for competitions rather than Organisers setting up their own. However, either option can be used.

### **RULE 13 SCORING**

In a match where the result is to be determined by the scoring of points, the method of scoring shall be agreed by all the competing Members or teams before the start of the match, unless provided for in the applicable regulations.

## SECTION II – TRACK EVENTS

Rules 17.2, 17.6 (except under Rules 54.12 and 55.9), 17.14, 18.2, 19 and 21.1 of the Technical Rules also apply to Parts VI, VII, and VIII of the Technical Rules.

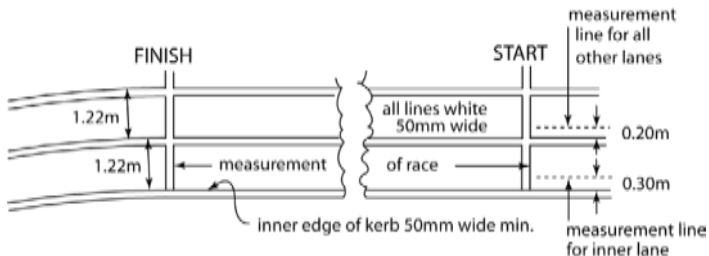
### RULE 14 TRACK MEASUREMENTS

1. The length of a standard running track shall be 400m. It shall consist of two parallel straights and two bends whose radii shall be equal. The inside of the track shall be bordered by a kerb of suitable material that should be coloured white, with a height of 50mm to 65mm and a width of 50mm to 250mm. The kerb on the two straights may be omitted and a white line 50mm wide substituted.

If a section of the kerb on a bend has to be temporarily removed for Field Events, its place on the surface beneath shall be marked with a white line 50mm in width and by cones or flags, minimum height 0.15m, placed on the white line so that the edge of the base of the cone or flag pole coincides with the edge of the white line closest to the track, and placed at intervals not exceeding 4m (2m for the curved part of an inside steeplechase diversion). (Flags shall be placed at an angle of 60° with the ground away from the track.) This (including also the option of temporary kerbing) shall also apply to the curved section of the steeplechase track where athletes divert from the main track to negotiate the water jump, to the outer half of the track in the case of starts according to Rule 17.5.2 of the Technical Rules and, optionally, to the straights, in this latter case, at intervals not exceeding 10m.

*Note: All points on the inside lane line at which the track changes from a curve to a straight or a straight to a curve shall be marked, in a distinctive colour 50mm x 50mm on the white line, by the surveyor and a cone placed at such points during a race.*

2. The measurement shall be taken 0.30m outward from the kerb or, where no kerb exists on a bend (or the diversion from the track for the steeplechase water jump), 0.20m from the line marking the inside of the track.



**Figure Rule 14 TR (Rule 160) - Track measurements** (infield view)

3. The distance of the race shall be measured from the edge of the start line farther from the finish to the edge of the finish line nearer to the start.
4. In all races up to and including 400m, each athlete shall have a separate lane, with a width of  $1.22\text{m} \pm 0.01\text{m}$ , including the lane line on the right, marked by white lines 50mm in width. All lanes shall be of the same nominal width. The inner lane shall be measured as stated in Rule 14.2, but the remaining lanes shall be measured 0.20m from the outer edges of the lines.

*Note: For all tracks constructed before 1 January 2004 for all such races, the lane may have a width of maximum 1.25m. However, when such a track is fully resurfaced, the lane width shall comply with this Rule.*

5. In International Competitions under paragraphs 1.1, 1.2, 1.3 and 1.6 of the International Competition definition, the track should allow for eight lanes minimum.
6. The lateral inclination of tracks towards the inside edge should not exceed 1:100 (1%) unless special circumstances exist which justify World Athletics providing an exemption, and the overall downward inclination in the running direction shall not exceed 1:1000 (0.1%).
7. Full technical information on track construction, layout and marking is contained in the World Athletics Track and Field Facilities Manual. This Rule gives basic principles, which must be followed.



When any section of the kerb is temporarily removed this should be kept to a minimum, sufficient to enable the Field Events to function fairly and efficiently.

Colours to use for marking the track are indicated on the Track Marking Plan included in the World Athletics Track and Field Facilities Manual.

### **RULE T14 (160) S 1 UKA SUPPLEMENT TRACK MEASUREMENTS**

The inside of the track should be bordered by a kerb of suitable material, approximately 5cm in width. The kerb on the two straights may be omitted and a white line 5cm wide substituted.

- (1) It is recommended that the direction of running shall be left hand inside.
- (2) For Championships or for any recognised National record to be accepted, the track must have been measured for distance either:-
  - (i) 30cm outwards from the outer edge of the kerbing if there is a raised border.
  - or
  - (ii) 20cm from the outer edge of the line if there is no raised border. In this case cones must be placed on the white line so that the base of the cone coincides with the outer edge of the inside line to prevent any athlete running on the lane line itself. These cones shall be no more than 4 metres apart and preferably closer to each other.

The measurement 20cm from the outer edge of the line also applies to that section of a steeplechase course where athletes divert from the main track to negotiate the water jump.

*NOTE: If a track has been measured and certificated as under 3(a) above and the kerbing is subsequently removed around any bend or bends the distances run by athletes using the inside lane, including those in middle distance races, will not be accurate. A performance set under these circumstances will not be acceptable as a qualifying standard for major International Championships or as a UK record.*

- (3) In measuring lanes for distance, the inner lane shall be measured as stated in 14.2 above and the other lanes 20cm from the outer edge of each subsequent lane line.
- (4) Races up to 100 metres must be run on a straight course so as to allow a separate lane for each competitor.
- (5) Individual races up to and including 400 metres should be run in lanes with a separate lane for each competitor.
- (6) Races over 400 metres and up to and including 800 metres may be run in lanes as far as the end of the first bend.

### **RULE 15 STARTING BLOCKS**

1. Starting blocks shall be used for all races up to and including 400m (including the first leg of the 4 × 200m, the Medley Relay and 4 × 400m) and shall not be used for any other race. When in position on the track, no part of the starting block shall overlap the start line or extend into another lane, with the exception that, provided there is no obstruction to any other athlete, the rear part of the frame may extend beyond the outer lane line.
2. Starting blocks shall comply with the following general specifications:
  - 21 The starting blocks shall consist of two foot plates, against which the athlete's feet are pressed in the starting position and which shall be mounted on a rigid frame. They shall be entirely rigid in construction and shall give no unfair advantage to the athlete. The frame shall in no way obstruct the athlete's feet as they leave the blocks.
  - 22 The foot plates shall be sloped to suit the starting position of the athlete and may be flat or slightly concave. The surface of the foot plates shall accommodate the spikes in the athlete's shoes, either by using slots or recesses in the face of the foot plate or by covering the surface of the foot plate with suitable material permitting the use of spiked shoes.
  - 23 The mounting of the foot plates on the frame may be adjustable, but it shall allow no movement during the actual start. In all cases, the foot plates shall be adjustable forward or backward in relation to each other. The adjustments shall

be secured by firm clamps or a locking mechanism, which can be easily and quickly operated by the athlete.

- 24 They shall be fixed to the track by a number of pins or spikes, arranged to cause the minimum possible damage to the track. The arrangement shall permit the starting blocks to be quickly and easily removed. The number, thickness and length of pins or spikes depend on the track construction. The anchorage shall permit no movement during the actual start.
- 25 When an athlete uses their own starting blocks, they shall comply with these Rules but otherwise may be of any design or construction, provided that they do not interfere with other athletes.
3. In competitions held under paragraphs 1.1, 1.2, 1.3 and 1.6 of the International Competition definition and for any performances submitted for ratification as a World Record under Rules 32 or 34 of the Competition Rules, the starting blocks shall be linked to a World Athletics certified Start Information System. This system is strongly recommended for other competitions.

*Note: In addition, an automatic recall system, within the Rules, may also be used.*

4. In competitions held under paragraphs 1.1 to 1.6 of the International Competition definition, athletes shall use starting blocks provided by the Organisers of the competition. In other competitions on synthetic surfaced tracks the Organisers may insist that only starting blocks provided by them may be used.

This Rule should also be interpreted so that:

- (a) no part of the frame or footplates can overlap a start line;
- (b) the frame only (but not any part of the footplate) can extend into the outer lane provided there is no obstruction. This reflects the long standing practice of athletes at the start of races on a bend placing their blocks at an angle to run the most direct line after the start.

The use of lights, by deaf or hearing impaired athletes only, at the start of races is allowed and is not considered assistance. It should however be the obligation of the athlete or their team for the financing and supply of such equipment and its compatibility with the start system in use, unless

at a particular meeting where there is an appointed technical partner who can provide it.

### **RULE T15 (161) S 1 UKA SUPPLEMENT STARTING BLOCKS**

The use of starting blocks is optional, except where blocks incorporating false start detection equipment are in use when all competitors shall be required to use only the starting blocks provided. If false start detection equipment is not in use, athletes may use their own starting blocks, but such starting blocks must be approved by the Starter.

For the avoidance of doubt in races up to and including 400m if the use of starting blocks is not compulsory (except as defined in Rule T15) then a crouch start does not have to be applied.

*NOTE: On synthetic surfaced tracks the Competition Provider may insist that only starting blocks provided by them shall be used.*

### **RULE 16 THE START**

1. The start of a race shall be denoted by a white line 50mm wide. In all races not run in lanes, the start line shall be curved, so that all the athletes start the same distance from the finish. Starting positions in events at all distances shall be numbered from left to right, facing the direction of running.

*Note (i): In the case of events starting outside the stadium, the start line may be up to 0.30m in width and may be of any colour contrasting distinctively with the surface of the start area.*

*Note (ii): The 1500m start line, or any other curved start line, may be extended out from the outside lane to the extent that the same synthetic surface is available.*

It is anticipated that, in order to efficiently complete the start procedures and for larger meetings to appropriately introduce the competitors in the race the athletes, when assembled, should be standing and facing in the direction of the race.

2. At all International Competitions, except as noted below, the commands of the Starter shall be given in their own language, in English or in French.
  - 2.1 In races up to and including 400m (including 4 × 200m, the Medley Relay as defined in Rule 24.1 of the Technical Rules and 4 × 400m), the commands shall be "On your marks" and "Set".
  - 2.2 In races longer than 400m (except 4 × 200m, the Medley Relay and 4 × 400m), the command shall be "On your marks".
  - 2.3 In any race when, under Rule 16.5, the Starter is not satisfied that all is ready for the start to proceed after the athletes are on their marks or they otherwise abort the start, the command shall be "Stand up".

All races shall normally be started by the report of the Starter's gun held upwards.

*Note: In competitions under paragraphs 1.1, 1.2, 1.3, 1.5 and 1.9 of the International Competition definition, the commands of the Starter shall be given in English only.*

The Starter must not initiate the start procedures before they are sure that the relevant timing team is ready as well as the Judges at the finish and in races up to and including 200m, the Wind Gauge Operator. The communication process between the start and the finish area and the timing team varies according to the level of the competition. In events organised under paragraphs 1.1 to 1.6 of the International Competition definition and many other high level meetings there is invariably a service company responsible for the electronic timing and the Start Information System. In this case, there will be technicians who are responsible for communication. In other competitions a variety of communication systems are used – radios, phones, or by using flags or flashing lights.

3. In races up to and including 400m (including the first leg of 4 × 200m, the Medley Relay and 4 × 400m), a crouch start and the use of starting blocks are compulsory. After the "On your marks"

command, an athlete shall approach the start line, assume a position completely within their allocated lane and behind the start line. An athlete shall not touch either the start line or the ground in front of it with their hands or their feet when on their mark. Both hands and at least one knee shall be in contact with the ground and both feet in contact with the foot plates of the starting blocks. At the "Set" command, an athlete shall immediately rise to their final starting position retaining the contact of the hands with the ground and of the feet with the foot plates of the blocks. Once the Starter is satisfied that all athletes are steady in the "Set" position, the gun shall be fired.

In all races using a crouch start, as soon as they are steady in their blocks, the Starter shall raise their arm in which they hold the gun, then they shall say "Set". They shall wait then for all the athletes to be steady and shall then fire the gun.

The Starter must not raise their arm too early, especially when manual Timekeepers are being used. They are advised to raise their arm only when they feel they are about to give the command "Set".

There is no rule that enables to determine the time that elapses between the commands "On your marks" and "Set" on one hand, and on the other hand, between the command "Set" and the gun shot. The Starter shall let the athletes go once they are all motionless in the correct starting position. Which means that they may have, for certain starts, to fire the gun quite quickly, but on the other hand, they may also have to wait longer in order to make sure that they are all steady in their starting position.

4. In races longer than 400m (except  $4 \times 200\text{m}$ , the Medley Relay and  $4 \times 400\text{m}$ ), all starts shall be made from a standing position. After the "On your marks" command, an athlete shall approach the start line and assume a starting position behind the start line (completely within their allocated lane in races started in lanes). An athlete shall not touch any part of the ground with their hand or hands and/or the start line or the ground in front of it with their feet when on their mark. Once the Starter is satisfied that all athletes are steady in the correct starting position, the gun shall be fired.
5. On the command "On your marks" or "Set", as the case may be, all athletes shall, at once and without delay, assume their full and final starting position. If, for any reason, the Starter is not satisfied that all

is ready for the start to proceed after the athletes are on their marks, they shall order all athletes to withdraw from their marks and the Starter's Assistants shall assemble them again (See also Rule 23 of the Competition Rules).

Where an athlete in the judgement of the Starter,

- 5.1 after the command "On your marks" or "Set", and before the report of the gun, causes the start to be aborted, for instance by raising a hand and/or standing or sitting up in the case of a crouch start, without a valid reason, (such reason to be evaluated by the relevant Referee); or
- 5.2 fails to comply with the commands "On your marks" or "Set" as appropriate, or does not place themselves in their final starting position at once and without delay; or
- 5.3 after the command "On your marks" or "Set" disturbs other athletes in the race through sound, movement or otherwise, the Starter shall abort the start.

The Referee may warn the athlete for improper conduct (disqualify in case of a second infringement of the Rule during the same competition), according to Rule 18.5 of the Competition Rules and Rule 7.2 of the Technical Rules. A green card shall not be shown. However, when an extraneous reason was considered to be the cause for aborting the start, or the Referee does not agree with the Starter's decision, a green card shall be shown to all the athletes to indicate that a false start was not committed by any athlete.

The division of the start rules into disciplinary matters (under Rule 16.5 of the Technical Rules) and false starts (Rules 16.7 and 16.8 of the Technical Rules) ensures that the whole field was not penalised for the actions of a single athlete. It is important in order to maintain the integrity of the intention of this division that Starters and Referees are as diligent in the application of Rule 16.5 of the Technical Rules as well as in detecting false starts.

Such conduct, whether wilful or unintentional perhaps through nervousness should cause Rule 16.5 of the Technical Rules to be applied although where the Starter is of the view that it was unintentional, the

application of Rule 16.2.3 of the Technical Rules only may be appropriate.

Conversely, there will be instances in which an athlete is entitled to request a delay of the start for legitimate reasons. It is therefore vital that the Start Referee (in particular) pays attention to the environment and conditions surrounding the start, especially in relation to factors of which the Starter may not be aware because they are focussing on preparing themselves for the start and/or wearing headphones.

In all such cases the Starter and Referee must act reasonably and efficiently and clearly indicate their decisions. If appropriate the reasons for the decisions can be announced to the athletes in the race and if possible or desirable also to the announcers, television team etc. through the communication network.

A green card shall not be shown in any case when a yellow or red card has been issued.

## **FALSE START**

6. When a World Athletics certified Start Information System is in use, the Starter and/or an assigned Recaller shall wear headphones in order to clearly hear the acoustic signal emitted when the System indicates a possible false start (i.e. when the reaction time is less than 0.100 second). As soon as the Starter and/or assigned Recaller hears the acoustic signal, and if the gun was fired, there shall be a recall and the Starter shall immediately examine the reaction times and other available information from the Start Information System in order to confirm which, if any, athlete(s) is/are responsible for the recall.

*Note: When a World Athletics certified Start Information System is in operation, the evidence of this equipment shall be used as a resource by the relevant officials to assist in making a correct decision.*

7. An athlete, after assuming a full and final starting position, shall not commence their start until after receiving the report of the gun. If, in the judgement of the Starter (including under Rule 22.6 of the Competition Rules), they do so any earlier, it shall be a false start. The commencement of the start is defined:



- 7.1 in the case of a crouch start, as any motion by an athlete that includes or results in one or both feet losing contact with the foot plate(s) of the starting blocks or one or both hands losing contact with the ground; and
- 7.2 In the case of a standing start, as any motion that results in one or both feet losing contact with the ground.

If the Starter determines that prior to receiving the report of the gun an athlete initiated a movement that was not stopped and continued into the commencement of their start, it shall also be a false start.

*Note (i): Any other motion by an athlete shall not be considered to be the commencement of their start. Such instances may, if applicable, be subject to a disciplinary warning or disqualification.*

*Note (ii): As athletes starting races in a standing position are more prone to over-balance, if such a movement is considered to be accidental, the start should be regarded as “unsteady”. If an athlete is pushed or jostled over the line before the start, they should not be penalised. Any athlete causing such interference may be subject to a disciplinary warning or disqualification.*

Generally, no false start should be charged if the athlete has not lost contact with the ground or foot plates. For example, if an athlete moves their hips up, but then moves them down without their hands or feet losing contact with the ground or foot plates at any time, it should not result in a false start. It may be a reason to warn (or disqualify if there has been a previous warning) the athlete for improper conduct under Rule 16.5 of the Technical Rules.

However in cases of a “rolling start” where the Starter (or Recaller) is of the opinion that an athlete has effectively anticipated the start through some continuous movement even if they did not move their hands or feet before the gun sounded, the race should be recalled. This can be done by a Starter or Recaller but it will be the Starter who is in the best situation to judge such a case as only they will know the position of their finger on the gun trigger when the athlete began their movement. In these cases where the Starter is sure that the athlete’s movement began before the report of the gun, a false start should be awarded.

In accordance with Note (ii) Starters and Referees should avoid being over-zealous in the application of Rule 16.7 of the Technical Rules to those events started from a standing position. Such instances are rare and usually occur unintentionally as it is easier to overbalance from a two-point start. It is not intended that same should be unduly penalised. If such a movement was considered to be accidental, Starters and Referees are encouraged to first consider calling the start “unsteady” and proceed according to Rule 16.2.3 of the Technical Rules. However repeat practices during the same event may entitle the Starter and/or Referee to consider applying either the false start or disciplinary procedures, as might best be applicable in the situation.

8. Except in Combined Events, any athlete responsible for a false start shall be disqualified by the Starter.

For Combined Events, see Rule 39.8.3 of the Technical Rules.

*Note: In practice, when one or more athletes make a false start, others are inclined to follow and, strictly speaking, any athlete who does so has also made a false start. The Starter should warn or disqualify only such athlete or athletes who, in their opinion, were responsible for the false start. This may result in more than one athlete being warned or disqualified. If the false start is not due to any athlete, no warnings shall be given and a green card shall be shown to all the athletes.*

9. In case of a false start, the Starter’s Assistants shall proceed as follows:

Except in Combined Events, the athlete(s) responsible for the false start shall be disqualified and a red and black (diagonally halved) card shall be raised in front of them.

In Combined Events, in case of a first false start, the athlete(s) responsible for the false start shall be warned with a yellow and black (diagonally halved) card raised in front of them. At the same time, all the other athletes taking part in the race shall be warned with the yellow and black card raised in front of them by one or several Starter's Assistants in order to notify them that anyone committing further false starts will be disqualified. In case of further false starts, the athlete(s) responsible for the false start shall be

disqualified and the red and black card shall be raised in front of them.

If lane markers that provide for it are being used, then whenever a card is shown to the athlete(s) responsible for the false start, the corresponding indication should be shown on the lane marker(s).

It is recommended that the size of the diagonally halved cards be A5 and that they be doubled sided. Note that the corresponding indication on the lane marker(s) may remain yellow and red as previously, in order to avoid unnecessary expense in modifying existing equipment.

10. The Starter or any Recaller, who is of the opinion that the start was not a fair one, shall recall the athletes by firing a gun.

The reference to a fair start does not relate solely to cases of a false start. This rule should also be interpreted as applying to other situations such as blocks slipping, a foreign object interfering with one or more athletes during a start etc.

### **RULE T16 (162) S 1 UKA SUPPLEMENT THE START Under 13, Under 15 and Masters' and Schools' Under 17 Age Groups**

In all competitions other than those where younger athletes are competing in a competition where Rule 16.6) above applies, whether false start detection equipment is in use or not, any athlete deemed responsible for a false start shall be warned. An athlete deemed responsible for two false starts shall be disqualified.

If in the opinion of the Starter, or the Start Recaller, the start was not fair, the competitors must be recalled with a second signal. If the Starter decides that the unfair start was due to one or more competitors 'beating the start signal' it shall be considered a false start.

*NOTE: In practice, when one or more competitors beat the start signal others are inclined to follow and strictly speaking, any competitor who does so has beaten the start signal. The Starter should warn (or disqualify) as appropriate, only such competitor or competitors who in*

*his or her opinion were responsible for beating the start signal. If the unfair start is not due to any competitor no warning shall be given.*

In the case of athletes competing in a Combined Events competition as defined in Rule T39 for the age groups identified in the previous paragraph, whether false start detection equipment is in use or not, any athlete deemed responsible for a false start shall be warned. Any athlete(s) responsible for three false starts shall be disqualified from the race.

## **RULE 17 THE RACE**

1. In races including at least one bend, the direction of running and walking shall be left-hand inside. The lanes shall be numbered with the left-hand inside lane numbered 1.

This rule allows where conditions permit and the track is properly surveyed, straight events to be conducted in the opposite direction, i.e. right-hand inside.

### **OBSTRUCTION**

2. If an athlete is jostled or obstructed during an event so as to impede their progress, then:
  - 21 if the jostling or obstruction is considered unintentional or is caused otherwise than by an athlete, the Referee may, if they are of the opinion that an athlete (or their team) was seriously affected, in accordance with Rule 18.7 of the Competition Rules or Rule 8.4 of the Technical Rules, order that the race (for one, some or all of the athletes) be re-held or allow the affected athlete (or team) to compete in a subsequent round of the event;
  - 22 if another athlete is found by the Referee to be responsible for the jostling or obstruction, such athlete (or their team) shall be liable to disqualification from that event. The Referee may, if they are of the opinion that an athlete (or their team) was seriously affected, in accordance with Rule 18.7 of the Competition Rules or Rule 8.4 of the Technical Rules, order that the race (for one, some or all of the athletes) be re-

held excluding any disqualified athlete (or team) or allow any affected athlete (or team) (other than any disqualified athlete or team) to compete in a subsequent round of the event.

*Note: In cases considered serious enough, Rule 18.5 of the Competition Rules and Rule 7.2 of the Technical Rules may also be applied.*

In both cases Rules 17.2.1 and 17.2.2 of the Technical Rules, such athlete (or team) should normally have completed the event with bona fide effort.

### **LANE INFRINGEMENT**

3. In all races:
  - 31 run in lanes, each athlete shall keep within their allocated lane from start to finish. This shall also apply to any portion of a race run in lanes;
  - 32 (or any part of races) not run in lanes, an athlete running on a bend, on the outer half of the track as per Rule 17.5.2 of the Technical Rules, or on any curved part of the diversion from the track for the steeplechase water jump, shall not step or run on or inside the kerb or line marking the applicable border (the inside of the track, the outer half of the track, or any curved part of the diversion from the track for the steeplechase water jump).

Except as stated in Rule 17.4 of the Technical Rules, if the Referee is satisfied, on the report of a Judge or Umpire or otherwise, that an athlete has infringed this Rule, they or in the case of a relay event, their team shall be disqualified.
4. An athlete, or in the case of a relay event, his team, shall not be disqualified if the athlete:
  - 41 are pushed or forced by another person to step or run outside their lane or on or inside the kerb or line marking the applicable border, or
  - 42 step or run outside their lane in the straight, any straight part of the diversion from the track for the steeplechase water jump or outside the outer line of their lane on the bend,

with no material advantage thereby being gained and no other athlete being jostled or obstructed so as to impede their progress. If material advantage is gained, the athlete (or team) shall be disqualified.

*Note: Material advantage includes improving their position by any means, including removing themselves from a “boxed” position in the race by having stepped or run inside the inside edge of the track.*

This Note specifically outlaws the practice of an athlete seeking to improve their position in races by moving onto the inside of the track (whether intentionally or after being pushed or jostled there by another athlete) to get out of a boxed position by running on the inside until clear. Whilst normally running on the inside of lane 1 in the straight (as distinct from doing so on the bend) would not lead to mandatory disqualification, the Referee now has the power to disqualify in their discretion if this occurs and the athlete is advantaged even if the initial reason for being there was the result of being pushed or jostled. In such cases the athlete should take immediate steps to return to the track without seeking or gaining any advantage.

## **RULE T17 (163) S 1 UKA SUPPLEMENT RUNNING ON THE LINE**

If the Referee considers that such action is unintentional, he or she may, at his or her discretion, disqualify if of the opinion that a material advantage was gained thereby.

For athletes in the U17 Age Group and below the Referee may, at his or her sole discretion, choose not to disqualify under Rules 17.3.1 or 17.3.2 if the infringement is considered to be insignificant.

5. In competitions held under paragraph 1.1 of the International Competition definition and where suitable in other competitions:
  - 5.1 the 800m event shall be run in lanes as far as the nearer edge of the breakline where athletes may leave their respective lanes. The breakline shall be an arced line marked after the first bend, 50mm wide, across all lanes other than lane 1. To assist athletes, identify the breakline, small cones, prisms or

other suitable markers, preferably of different colour from the breakline and the lane lines, shall be placed on the lane lines immediately before the intersection of the lane lines and the breakline.

*Note: In competitions under paragraphs 1.4 and 1.8 of the International Competition definition, the participating teams may agree not to use lanes.*

- 52 when there are more than 12 athletes in a race over 1000m, 2000m, 3000m, (optionally, 3000m Steeplechase with inside water jump), 5000m or 10,000m, they may be divided into two groups with one group of approximately two thirds of the athletes on the regular arced start line and the other group on a separate arced start line marked across the outer half of the track. The other group shall run as far as the end of the first bend of the race on the outer half of the track, which shall be marked by cones, flags or temporary kerbing as described in Rule 14.1 of the Technical Rules.

The separate arced start line shall be positioned in such a way that all the athletes shall run the same distance.

The breakline for 800m indicates where the athletes in the outer group in 2000m and 10,000m may join the athletes using regular start.

For group starts in 1000m, 3000m, (optionally 3000m steeplechase with inside water jump) and 5000m, the track shall be marked at the beginning of the finish straight to indicate where athletes starting in the outer group may join the athletes using the regular start. This mark may be a 50mm × 50mm mark on the line between lanes 4 and 5 (lanes 3 and 4 in a six-lane track) immediately before which a cone or flag is placed until the two groups converge.

- 53 If an athlete does not follow this Rule they, or in the case of a relay their team, shall be disqualified.

The markers used on the breakline for the 800m and applicable relays should be 50mm × 50mm and no more than 0.15m high.

For clarity when complying with Rule 25.4 of the Competition Rules when stating the Rule under which an athlete is disqualified:

- (a) if an athlete steps on or inside the line then state Rule 17.3 of the Technical Rules
- (b) if an athlete crosses over before the breakline or split start marker then state Rule 17.5 of the Technical Rules.

## **LEAVING THE TRACK**

- 6. An athlete, after voluntarily leaving the track, except in compliance with Rule 24.6.3 of the Technical Rules, shall not be allowed to continue in the race and shall be recorded as not finishing the event. Should the athlete attempt to re-enter the race, they shall be disqualified by the Referee.

## **CHECK-MARKS**

- 7. Except as stated in Rule 24.4 of the Technical Rules, when all or the first portion of a Relay Race is being run in lanes, athletes may not make check-marks or place objects on or alongside the running track for their assistance. The Judges shall direct the relevant athlete to adapt or remove any marks or objects not complying with this Rule. If they do not, the Judges shall remove them.

*Note: Serious cases may further be dealt with under Rule 18.5 of the Competition Rules and Rule 7.2 of the Technical Rules.*

## **WIND MEASUREMENT**

- 8. All wind gauge equipment shall be manufactured and calibrated according to international standards. The accuracy of the measuring equipment used in the competition shall have been verified by an appropriate organisation accredited by the national measurement authority.
- 9. Non-mechanical wind gauges shall be used at all International Competitions under paragraphs 1.1 to 1.8 of the International Competition definition and for any performance submitted for ratification as a World Record.

A mechanical wind gauge should have appropriate protection to reduce the impact of any crosswind. Where tubes are used, their length on either side of the measuring device should be at least twice the diameter of the tube.



10. The Track Referee shall ensure that the wind gauge for Track Events is placed beside the straight, adjacent to lane 1, 50m from the finish line. The measuring plane shall be positioned  $1.22\text{m} \pm 0.05\text{m}$  high and not more than 2m away from the track.
11. The wind gauge may be started and stopped automatically and/or remotely, and the information conveyed directly to the competition computer.
12. The periods for which the wind velocity shall be measured from the flash / smoke of the Starter's gun are as follows:
 

	Seconds
100m	10 (Also to apply to all distances up to 100m)
100m Hurdles	13
110m Hurdles	13

In the 200m event, the wind velocity shall normally be measured for a period of 10 seconds commencing when the first athlete enters the straight.

13. The wind gauge shall be read in metres per second, rounded to the next higher tenth of a metre per second, unless the second decimal is zero, in the positive direction (that is, a reading of +2.03 metres per second shall be recorded as +2.1; a reading of -2.03 metres per second shall be recorded as -2.0). Gauges that produce digital readings expressed in tenths of metres per second shall be constructed so as to comply with this Rule.

#### **INDICATION OF INTERMEDIATE TIMES**

14. Intermediate times and preliminary winning times may be officially announced and/or displayed. Otherwise, such times must not be communicated to the athletes by persons in the competition area without the prior approval of the appropriate Referee who may authorise or appoint no more than one person to call times at each of no more than two agreed timing points.

Athletes who receive intermediate times that have been communicated in violation of this Rule shall be considered to have received assistance and shall be subject to the provisions of Rule 6.2 of the Technical Rules.

*Note: The competition area, which normally also has a physical barrier, is defined for this purpose as the area where the competition is being staged and which has an access restricted to the competing athletes and personnel authorised in accordance with the relevant Rules and Regulations.*

## **DRINKING / SPONGING**

### 15. Drinking / Sponging, as follows:

- 151 In Track Events of 5000m or longer, the Organisers may provide water and sponges to athletes if weather conditions warrant such provision.
- 152 In Track Events longer than 10,000m, refreshments, water and sponging stations shall be provided. Refreshments may be provided either by the Organisers or the athlete and shall be placed so that they are easily accessible to, or may be put by authorised persons into the hands of, the athletes. Refreshments provided by the athletes shall be kept under the supervision of officials designated by the Organisers from the time that the refreshments are lodged by the athletes or their representatives. Those officials shall ensure that the refreshments are not altered or tampered with in any way.
- 153 An athlete may, at any time, carry water or refreshment by hand or attached to their body provided it was carried from the start or collected or received at an official station.
- 154 An athlete who receives or collects refreshment or water from a place other than the official stations, except where provided for medical reasons from or under the direction of race officials, or takes the refreshment of another athlete, should, for a first such offence, be warned by the Referee normally by showing a yellow card. For a second offence, the Referee shall disqualify the athlete, normally by showing a red card. The athlete shall then immediately leave the track.

*Note: An athlete may receive from or pass to another athlete refreshment, water or sponges provided it was carried from the start or collected or received at an official station. However, any continuous support from an athlete to one or more others*

*in such a way may be regarded as unfair assistance and warnings and/or disqualifications as outlined above may be applied.*

### **RULE 18 THE FINISH**

1. The finish of a race shall be denoted by a white line 50mm wide.  
*Note: In the case of events finishing outside the stadium, the finish line may be up to 0.30m in width and may be of any colour contrasting distinctively with the surface of the finish area.*
2. The athletes shall be placed in the order in which any part of their bodies (i.e. torso, as distinguished from the head, neck, arms, legs, hands or feet) reaches the vertical plane of the nearer edge of the finish line as defined above.
3. In any race decided on the basis of the distance covered in a fixed period of time, the Starter shall fire the gun exactly one minute before the end of the race to warn athletes and Judges that the race is nearing its end. The Starter shall be directed by the Chief Timekeeper and, at exactly the appropriate time after the start, they shall signal the end of the race by again firing the gun. At the moment the gun is fired to signal the end of the race, the Judges appointed for that purpose shall mark the exact spot where each athlete touched the track for the last time before or simultaneously with the firing of the gun.  
The distance achieved shall be measured to the nearest metre behind this mark. At least one Judge shall be assigned to each athlete before the start of the race for the purpose of marking the distance achieved.

[Guidelines for the conduct of the One Hour Race may be downloaded from the World Athletics website.](#)

### **RULE 19 TIMING AND PHOTO FINISH**

1. Three methods of timekeeping shall be recognised as official:
  - 1.1 Hand Timing;
  - 1.2 Fully Automatic Timing obtained from a Photo Finish System;

- 1.3 Timing provided by a Transponder System for competitions held under Rules 54 (races not held completely in the stadium), 55, 56, and 57 of the Technical Rules only.
2. Under Rule 19.1.1 and 19.1.2 of the Technical Rules, the time shall be taken to the moment at which any part of the body of an athlete (i.e. torso, as distinguished from the head, neck, arms, legs, hands or feet) reaches the vertical plane of the nearer edge of the finish line.
3. Times for all finishers shall be recorded. In addition, whenever possible, lap times in races of 800m and over and intermediate times at every 1000m in races of 3000m and over shall be recorded.

### **HAND TIMING**

4. The Timekeepers shall be in line with the finish and, where possible, they should be placed at least 5m from the outside lane of the track. In order that they may all have a good view of the finish line, an elevated stand should be provided.
5. Timekeepers shall use manually operated electronic timers with digital readouts. All such timing devices are termed "watches" for the purpose of the Rules.
6. The lap and intermediate times as per Rule 19.3 of the Technical Rules shall be recorded either, by designated members of the timekeeping team using watches capable of taking more than one time, or by additional Timekeepers, or by transponders.
7. The time shall be taken from the flash / smoke of the gun.
8. Three official Timekeepers (one of whom shall be the Chief Timekeeper) and one or two additional Timekeepers shall time the winner of every event and any performances for record purposes. (For Combined Events, see Rule 39.8.2 of the Technical Rules.) The times recorded by the additional Timekeepers' watches shall not be considered unless one or more of the official Timekeepers' watches fail to record the time correctly, in which case the additional Timekeepers shall be called upon, in such order as has been decided previously, so that in all the races, three watches should have recorded the official winning time.
9. Each Timekeeper shall act independently and without showing their watch to, or discussing their time with, any other person, shall enter their time on the official form and, after signing it, hand it to the Chief Timekeeper who may examine the watches to verify the reported times.

10. For all hand-timed races, times shall be read and recorded as follows:
  - 10.1 For races on the track, unless the time is an exact 0.1 second, the time shall be converted and recorded to the next longer 0.1 second, e.g. 10.11 shall be recorded as 10.2.
  - 10.2 For races partly or entirely outside the stadium, unless the time is an exact whole second, the time shall be converted and recorded to the next longer whole second, e.g. 2:09:44.3 shall be recorded as 2:09:45.
11. If, after converting as indicated above, two of the three watches agree and the third disagrees, the time recorded by the two shall be the official time. If all three watches disagree, the middle time shall be official. If only two times are available and they disagree, the longer time shall be official.
12. The Chief Timekeeper, acting in accordance with the Rules mentioned above, shall decide the official time for each athlete and provide the results to the Competition Secretary for distribution.

**FULLY AUTOMATIC TIMING AND PHOTO FINISH SYSTEM  
THE SYSTEM**

13. A Fully Automatic Timing and Photo Finish System must have been tested, and have a certificate of accuracy issued within 4 years of the competition, including the following:
  - 13.1 The System must record the finish through a camera positioned in the extension of the finish line, producing a composite image.
    - (i) For competitions under paragraph 1.1 of the International Competition definition, this composite image must be composed of at least 1000 images per second.
    - (ii) For other competitions, this composite image must be composed of at least 100 images per second.
 In each case, the image must be synchronised with a uniformly marked time-scale graduated in 0.01 seconds.
  - 13.2 The System shall be started automatically by the Starter's signal, so that the overall delay between the report from the muzzle or its equivalent visual indication and the start of the timing system is constant and equal to or less than 0.001 second.

14. In order to confirm that the camera is correctly aligned and to facilitate the reading of the Photo Finish image, the intersection of the lane lines and the finish line shall be coloured black in a suitable design. Any such design must be solely confined to the intersection, for no more than 20mm beyond, and not extended before, the leading edge of the finish line. Similar black marks may be placed on each side of the intersection of an appropriate lane line and the finish line to further facilitate reading.
15. The placing of the athletes shall be identified from the image by means of a cursor with its reading line guaranteed to be perpendicular to the time scale.
16. The System must automatically determine and record the finish times of the athletes and must be able to produce a printed image which shows the time of any athlete. Additionally, the system shall provide a tabular overview which shows the time or other result of every athlete. Subsequent changes of automatically determined values and manual input of values (such as start time, finish time), shall be indicated by the system automatically in the time scale of the printed image and the tabular overview.
17. A system which operates automatically at the finish, but not at the start, shall be considered to produce Hand Times provided that the system was started in accordance with Rule 19.7 of the Technical Rules or with equivalent accuracy. The image may be used as a valid support in order to determine placings and adjust time intervals between athletes.

*Note: If the timing mechanism is not started by the Starter's signal, the time-scale on the image shall indicate this fact automatically.*

18. A system, which operates automatically at the start but not at the finish, shall be considered to produce neither Hand nor Fully Automatic Times and shall not therefore be used to obtain official times.

## **OPERATION**

19. The Chief Photo Finish Judge shall be responsible for the functioning of the System. Before the start of the competition, they will meet the technical staff involved and familiarise themselves with the equipment, checking all applicable settings.

In cooperation with the Track Referee and the Starter, they shall initiate a zero control test, before the beginning of each session, to ensure that the equipment is started automatically by the Starter's signal within the limit identified in Rule 19.13.2 of the Technical Rules (i.e. equal to or less than 0.001 second).

They shall supervise the testing of the equipment and ensure that the camera(s) is (are) correctly aligned.

20. There should be at least two photo finish cameras in action, one from each side. Preferably, these timing systems should be technically independent, i.e. with different power supplies and recording and relaying of the Starter's signal, by separate equipment and cables.

*Note: Where two or more Photo Finish cameras are used, one should be designated as official by the Technical Delegate(s) (or International Photo Finish Judge where appointed) before the start of the competition. The times and places from the images of the other camera(s) should not be considered unless there is reason to doubt the accuracy of the official camera or if there is need to use the supplementary images to resolve uncertainties in the finishing order (i.e. athletes wholly or partially obscured on the image from the official camera).*

21. In conjunction with an adequate number of assistants, the Chief Photo Finish Judge shall determine the placing of the athletes and, as a consequence, their official times. They shall ensure that these results are correctly entered in or transferred to the competition results system and conveyed to the Competition Secretary.

At major events where the technology is available, the photo finish image is often immediately provided on the video board or published on the internet. It has become the practice to provide athletes, or persons on their behalf, who are considering making a protest or appeal the opportunity to see the photo, in order to avoid time being spent on any unnecessary protests or appeals.

22. Times from the Photo Finish System shall be regarded as official unless for any reason the appropriate official decides that they obviously must be inaccurate. If such is the case, the times of the back-up Timekeepers, if possible adjusted based on information on

time intervals obtained from the Photo Finish image, shall be official. Such back-up Timekeepers must be appointed where any possibility exists of failure of the timing system.

23. Times shall be read and recorded from the Photo Finish image as follows:
  - 23.1 For all races up to and including 10,000m, unless the time is an exact 0.01 second, the time shall be converted and recorded to the next longer 0.01 second, e.g. 26:17.533 shall be recorded as 26:17.54.
  - 23.2 For all races on the track longer than 10,000m, all times not ending in two zeroes shall be converted and recorded to the next longer 0.1 second, e.g. 59:26.322 shall be recorded as 59:26.4.
  - 23.3 For all races held partly or entirely outside the stadium, all times not ending in three zeroes shall be converted and recorded to the next longer whole second, e.g. 2:09:44.322 shall be recorded as 2:09:45.

#### **TRANSPONDER SYSTEM**

24. The use of Transponder Timing Systems complying with the Rules in events held under Rules 54 (races not held completely in the stadium), 55, 56, and 57 of the Technical Rules is permitted provided that:
  - 24.1 None of the equipment used at the start, along the course or at the finish line constitutes a significant obstacle or barrier to the progress of an athlete.
  - 24.2 The weight of the transponder and its housing carried or worn by the athlete is not significant.
  - 24.3 The System is started by the Starter's gun or synchronised with the start signal.
  - 24.4 The System requires no action by an athlete during the competition, at the finish or at any stage in the result processing.
  - 24.5 For all races, all times not ending in zero shall be converted and recorded to the next longer whole second, e.g. 2:09:44.3 shall be recorded as 2:09:45.



*Note: The official time shall be the time elapsed between the firing of the starting gun (or the synchronised start signal) and the athlete reaching the finish line. However, the time elapsed between an athlete crossing the start line and the finish line can be made known to them but will not be considered an official time.*

- 24.6 Whilst the determination of the finishing order and times may be considered official, Rules 18.2 and 19.2 of the Technical Rules must be applied where required.

*Note: It is recommended that Judges and/or video recording(s) also be provided to assist in determining the finishing order and the identification of athletes.*

It is important that when using transponder timing that appropriate back-up systems are put in place by the Organisers, especially to respect Rule 19.24.6 of the Technical Rules. The provision of back-up Timekeepers, and more importantly Finish Judges to adjudicate on close finishes (which might not be differentiated by chip timing) is strongly recommended.

25. The Chief Transponder Timing Judge shall be responsible for the functioning of the System. Before the start of the competition, they will meet the technical staff involved and familiarise themselves with the equipment, checking all applicable settings. They shall supervise the testing of the equipment and ensure that the passing of the transponder over the finish line will record the athlete's finish time. In conjunction with the Referee, they shall ensure that provision is made for the application, when necessary, of Rule 19.24.6 of the Technical Rules.

### **RULE T19 (165) S 1 UKA SUPPLEMENT UK RECORDS**

In the event of a National record claim the time should be taken by three graded Timekeepers, each of whom should be at level 4. If a fully automatic finish system is not in operation they must show their timings to the Chief Timekeeper and certify these times on the appropriate Record Application form.

**RULE T19 S 2 UKA SUPPLEMENT  
TIMING RACERUNNING EVENTS**

The judging and timing of RaceRunning events shall be conducted in the same manner as applied to Wheelchair Races and defined in Rules 19.3 and 20.3 of the World Para Athletics Rules and Regulations.

**RULE 20 SEEDINGS, DRAWS AND QUALIFICATION IN  
TRACK**

**ROUNDS AND HEATS**

1. Qualification Rounds shall be held in Track Events in which the number of athletes is too large to allow the competition to be conducted satisfactorily in a single round (final). Where Qualification Rounds are held, all athletes must compete in, and qualify through, all such rounds except that the relevant governing body may, for one or more events, authorise the conduct of additional preliminary qualification round(s) either at the same competition or at one or more earlier competition(s) to determine some or all of the athletes who shall be entitled to participate and in which round of the competition. Such procedure and any other means (such as achieving entry standards during a specified period, by specified placing in a designated competition or by specified rankings) by which an athlete is entitled to participate, and in which round of the competition, shall be set out in the regulations for each competition.

*Note: See also Rule 8.4.3 of the Technical Rules.*

2. The Qualification Rounds for Track Events shall be arranged as follows by the appointed Technical Delegates. If no Technical Delegates have been appointed, they shall be arranged by the Organisers.
  - 2.1 The regulations for each competition should include tables which shall, in the absence of extraordinary circumstances, be used to determine the number of rounds, the number of heats in each round and the qualification procedure, i.e. those to advance by place (P) and time (T). Such information shall also be provided for any preliminary qualifications.

*Note: Tables which may be used in the absence of any*

- 2.2 Whenever possible, representatives of each Member or team and the best performed athletes shall be placed in different heats in all Qualification Rounds of the competition. In applying this Rule after the first round, the required exchanges of athletes between heats should, to the extent possible, be made between athletes seeded in the same “group of lanes” according to Rule 20.4.2 of the Technical Rules.
- 2.3 When heats are being arranged, as much information as possible about the performances of all athletes should be considered and the heats drawn so that, normally, the best performed athletes reach the final.

The Qualification Rounds should determine in the best possible way the athletes who will take part in the next round and eventually the final. This includes avoiding where possible the clashing of the best performed athletes (determined generally on performance in the qualification period but also taking into account such matters as outstanding recent career records) in the same heats as also applies to athletes from the same Member or team.

For major competitions, at least, the basis of the seeding should be the best times achieved by each athlete in valid conditions (including with wind readings for the relevant events) during the pre-determined period. This period may be specified in the Technical Regulations or in the document setting out the entry conditions and standards for the competition. Where there is no such specification, then “Season Best” should be used unless the Technical Delegate(s) or the Organisers decide that for one, some or all events the circumstances justify an alternate period or other criteria being applied.

Such factors as performances achieved during training or tests, even if they appeared to look like competition or notions about what an athlete might “be worth” but has never achieved, should not be taken into account in seeding.

The requirements of the Rule in relation to the “best performed athletes” does require some deviation from the strict protocol outlined above. For

example, an athlete who might normally be seeded in a high position might not have any, or only a poor, valid performance in the predetermined period (through injury, illness, ineligibility or in the case of indoor meetings only have outdoor results). Whilst they would normally be placed lower or at the bottom of the seeding list, adjustment should be considered by the Technical Delegate(s). Similar principles should be applied to avoid a clash in a Qualification Round between athletes considered to be the favourites to place highly in the event if the results of the previous round would strictly dictate that they should be in the same heat. At this same time any adjustments to ensure as much as possible that athletes from the same nation or team are in different heats should also be made.

In all such cases, adjustments of the seeding should be made after the initial allocation to the heats but before any draw is made for the lanes. After these changes are made, a final check should be made to ensure that the heats are as equal as possible.

In applying these principles exchanges of athletes should be made:

- a. in the first round, between athletes with a similar ranking on the list of best valid performances during the pre-determined period; and
- b. in subsequent rounds, between athletes seeded in the same “group of lanes” according to Rule 20.4.2 of the Technical Rules.

Following these principles is more important in competitions in which the number of rounds has been reduced in some events - making accurate and well considered seeding vital to achieving both a fair and an athletically appealing outcome.

For lower level competitions, the Technical Delegate(s) or the Organisers may consider use different principles to achieve a similar final outcome.

## **RANKING AND COMPOSITION OF HEATS**

3. Ranking and Composition of Heats, as follows:

- 3.1 For the first round, the athletes shall be ranked with the seeding determined from the relevant list of valid performances achieved during the predetermined period.
- 3.2 After the first round:
  - (i) for events of 100m to 400m inclusive, and relays up to and including 4 × 400m, seeding shall be based upon

placings and times of each previous round. For this purpose, athletes shall be ranked as follows:

Fastest heat winner

2nd fastest heat winner

3rd fastest heat winner, etc.

Fastest 2nd place

2nd fastest 2nd place

3rd fastest 2nd place, etc.

(Concluding with)

Fastest time qualifier

2nd fastest time qualifier

3rd fastest time qualifier, etc.

- (ii) for other events, the original performance lists shall continue to be used for seeding, modified only by improvements in performances achieved during the earlier round(s).

- 3.3 In each case, the athletes shall then be placed in heats in the order of seeding in a zigzag distribution, e.g. three heats will consist of the following seedings:

A     1    6    7    12 13 18 19 24

B     2    5    8    11 14 17 20 23

C     3    4    9    10 15 16 21 22

- 3.4 In each case, the order in which heats are to be run shall be determined by draw after the composition of the heats has been decided.

For the first round in order to reduce the number of heats required, it is acceptable and normal for additional available lanes (for example a ninth lane on a straight or oval track) to be used in races up to and including 400m and to have more than one athlete in a lane at the start of an 800m race.

The random draw to determine the order in which the heats are conducted is based on fairness. In middle and long distance races the athletes running in the last heat will know as far as qualifying by times the performance they have to realise in order to qualify. Even with the shorter races there is a fairness aspect as weather conditions can change (rain

suddenly falling or an alteration in wind strength or direction). Fairness dictates that order be determined by chance.

### **DRAW FOR LANES**

4. For events 100m to 800m inclusive, and relays up to and including 4 × 400m, where there are several successive rounds of a race, lanes will be drawn as follows:

4.1 For the first round and any additional preliminary qualification round as per Rule 20.1 of the Technical Rules, the lane order shall be drawn by lot.

4.2 After the first round, athletes shall be ranked after each round in accordance with the procedure shown in Rule 20.3.2(i) or, in the case of 800m, 20.3.2(ii) of the Technical Rules.

Three draws for lanes will then be made:

(i) one for the four highest ranked athletes or teams to determine placings in lanes 3, 4, 5 and 6;

(ii) another for the fifth and sixth ranked athletes or teams to determine placings in lanes 7 and 8, and

(iii) another for the two lowest ranked athletes or teams to determine placings in lanes 1 and 2.

*Note: When there are fewer or more than 8 lanes, the above system with the necessary modifications should be followed.*

*Note (i): In competitions under paragraphs 1.4 to 1.10 of the International Competition definition, the 800m event may be run with one or two athletes in each lane, or with group start behind an arced line. In competitions under paragraphs 1.1, 1.2, 1.3 and 1.6 of the International Competition definition, this should normally be applied only in the first round, unless because of ties or advancement by the Referee or the Jury of Appeal, there are more athletes in a race of a subsequent round than were anticipated.*

*Note (ii): In any 800 metres race, including a final, where for any reason there are more athletes competing than lanes available, the Technical Delegate(s) shall determine in which lanes more than one athlete will be drawn.*

*Note (iii): When there are more lanes than athletes, the inside lane(s) should always remain free.*

With regard to Note (ii), there is no exact specification as to how the Technical Delegates should act as the situations which may give rise to it may vary greatly. However, this issue only affects the running of the first bend of the race and is not as important as the allocation of lanes in a shorter race. Technical Delegate(s) are advised to place the additional athlete(s) in the lane(s) where the "double-up" will cause least inconvenience - usually the outer lanes so that the athletes are not running around a tighter bend together.

As to Note (iii), where a stadium has more than eight lanes available, the Technical Delegate(s) (or if none the Organisers) should decide in advance which lanes are to be used for this purpose. For example, in the case of a nine-lane oval track, lane one would not be used in cases where less than nine athletes are taking part in a race. Consequently, for the purposes of Rule 20.4 of the Technical Rules, lane 2 is regarded as lane 1 and so on.

5. In competitions under paragraphs 1.1, 1.2, 1.3 and 1.6 of the International Competition definition, for events longer than 800m, relays longer than  $4 \times 400\text{m}$  and any event where only a single round (final) is required, lanes / starting positions shall be drawn by lot.
6. Where it is decided to conduct a series of races in an event rather than rounds and finals, the regulations for the competition shall set out all relevant considerations including seedings and draws and the method by which the final results will be determined.
7. An athlete shall not be allowed to compete in a heat or lane other than the one in which their name appears, except in circumstances which, in the opinion of the Technical Delegate(s) or the Referee, justify an alteration.

### **PROGRESSION**

8. In all Qualification Rounds, the tables should, where practicable, allow at least the first and second places in each heat to qualify for the next round and it is recommended that, where possible, at least three in each heat should qualify.  
 Except where Rule 21 of the Technical Rules applies, any other athletes may qualify by place or by time according to Rule 20.2 of the Technical Rules, the applicable Technical Regulations, or as determined by the Technical Delegate(s). When athletes are

qualified according to their times, only one system of timing may be applied.

*Note: In races longer than 800 metres where rounds are conducted, it is recommended that only a small number of athletes qualify by time.*

Where tables are prescribed in the regulations for a competition it is usual that the principle set out in Rule 20.8 of the Technical Rules will have been incorporated. Where not, the Technical Delegates or Organisers should follow same when establishing the progression table to be used. There will however be occasions when Rule 21 of the Technical Rules may cause a variation to be applied, particularly where there is a tie for the last qualifying position based on place. In such cases, it may be necessary for one less athlete to progress on time. In circumstances where there are sufficient additional lanes available, or in the case of the 800m (where a lane at the start may be used for more than one athlete) or a non-laned race, the Technical Delegate(s) may decide to progress an additional athlete(s).

Because of the provision within Rule 20.8 of the Technical Rules that for time qualification only one system of timing may be applied it is important for back-up timing systems to be available for preliminary rounds in case the primary system (usually photo finish) fails. In the event that only times from different timing systems are available for two or more heats, the Technical Delegates in conjunction with the Track Referee should determine, within the circumstances of the particular competition, the fairest method for determining those athletes who should proceed to the next round. Where additional lanes are available, it is recommended that this option be considered first.

## **ONE DAY MEETINGS**

9. In competitions held under paragraphs 1.5, 1.9 and 1.10 of the International Competition definition athletes may be seeded, ranked and/or allocated to lanes in accordance with the applicable regulations for the competition or any other method determined by the Organisers but preferably notified to the athletes and their representatives in advance.



In one day meetings, if there is only a “final” round but with more than one race, the races should be arranged according to any applicable regulations for the meeting or the series of meetings of which it is a part. If there are none then it is usual for allocation of athletes to the various “races” to be undertaken by the Organisers or if requested by the appointed Technical Delegate(s).

Similar considerations apply to how the final ranking of the athletes in such events will be made. In some meetings the “race(s)” other than the main race are regarded as separate races and are not considered for the overall ranking but in others the results of more than one race are “combined” to give the overall ranking. It is highly advisable to ensure that whichever is to apply for the competition is also notified to the participants in advance as it may affect prizes and other considerations.

### **MINIMUM TIMES BETWEEN ROUNDS**

10. The following minimum times must be allowed, when practicable, between the last heat of any round and the first heat of a subsequent round or final:

Up to and including 200m	45 minutes
Over 200m up to and including 1000m	90 minutes
Over 1000m	Not on the same day

### **RULE T20 (166) S 1 UKA SUPPLEMENT SEEDINGS, DRAWS AND QUALIFICATIONS**

#### **Qualification from preliminary heats**

The following minimum times must be allowed between the last heat of the round and the first heat of the subsequent round or final.

Up to 100 metres	20 minutes
Over 100m and up to 200m	40 minutes
Over 200m and up to 400m	60 minutes
Over 400m and up to 800m	80 minutes
Over 800m	100 minutes

## **RULE 21 TIES**

1. If the Judges or the Photo Finish Judges are unable to separate the athletes for any place according to Rules 18.2, 19.17, 19.21 or 19.24 of the Technical Rules (as may be applicable), it shall be determined to be a tie and the tie shall remain.

### **TIE FOR RANKING POSITION (ACCORDING TO RULE 20.3.2 OF THE TECHNICAL RULES)**

2. If there is a tie for any ranking position under Rule 20.3.2 of the Technical Rules, the Chief Photo Finish Judge shall consider the actual times recorded by the athletes to 0.001 second and if it is equal, it shall be determined to be a tie and lots shall be drawn to determine the higher ranking position.

### **TIE FOR LAST QUALIFYING POSITION BASED ON PLACE**

3. If after the application of Rule 21.1 of the Technical Rules, there is a tie for a last qualifying position based on place, if there are lanes or positions available (including lane sharing in 800m races) the tying athletes shall be placed in the next round. If that is not practicable lots shall be drawn to determine which athlete(s) shall be placed in the next round.
4. Where qualifying for the next round is based on place and time (e.g., the first three in each of two heats plus the next two fastest), and there is a tie for the last qualifying position based on place, placing the tied athletes in the next round shall reduce the number of athletes qualifying based on time.

### **TIE FOR LAST QUALIFYING POSITION BASED ON TIME**

5. If there is a tie for a last qualifying position based on time, the Chief Photo Finish Judge shall consider the actual times recorded by the athletes to 0.001 second and if it is equal, it shall be determined to be a tie. If there are lanes or positions available (including lane sharing in 800m races) the tying athletes shall be placed in the next round. If that is not practicable lots shall be drawn to determine which athlete(s) shall be placed in the next round.

## **RULE 22 HURDLE RACES**

1. The standard distances shall be:  
Men, U20 Men and U18 Men: 110m, 400m

Women, U20 Women and U18 Women: 100m, 400m

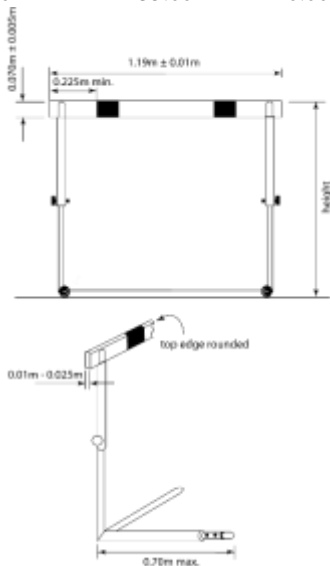
There shall be ten flights of hurdles in each lane, set out in accordance with the following table:

**MEN, U20 MEN AND U18 MEN**

Distance of race	Distance from start line to first hurdle	Distance from start line to hurdles	Distance from between last hurdle to finish line
110m	13.72m	9.14m	14.02m
400m	45.00m	35.00m	40.00m

**WOMEN, U20 WOMEN AND U18 WOMEN**

Distance of race	Distance from start line to first hurdle	Distance from start line to hurdles	Distance from between last hurdle to finish line
100m	13.00m	8.50m	10.50m
400m	45.00m	35.00m	40.00m



**Figure Rule 22 TR (Rule 168) - Example of a hurdle**

Each hurdle shall be so placed on the track that the feet shall be on the side of the approach by the athlete. The hurdle shall be so placed that the vertical plane of the side of the bar nearer to the approaching hurdler coincides with the track marking nearest the athlete.

2. The hurdles shall be made of metal or some other suitable material with the top bar of wood or other non-metallic suitable material. They shall consist of two feet and two uprights supporting a rectangular frame, reinforced by one or more cross bars, the uprights to be fixed at the extreme end of each base. The hurdle shall be of such a design that a force at least equal to the weight of 3.6kg applied horizontally to the centre of the top edge of the top bar is required to tilt it. The hurdle may be adjustable in height for each event. The counterweights shall be adjustable so that at each height a force at least equal to the weight of 3.6kg and not more than 4kg is required to tilt it. The maximum horizontal deflection of the top bar of a hurdle (including any deflection of the uprights) when subject to a centrally applied force equal to the weight of 10kg shall not exceed 35mm.

3. Dimensions: The standard heights of the hurdles shall be:

Distance	Men	U20 Men	U18 Men	Women/U20	U18 Women
110m/100m	1.067m	0.991m	0.914m	0.838m	0.762m
400m	0.914m	0.914m	0.838m	0.762m	0.762m

*Note: Due to manufacturing varieties, hurdles up to 1.000m are also acceptable in the U20 110m Hurdles.*

In each case, there shall be a tolerance allowance of 3mm, above and below the standard heights, to allow for variation in the manufacture. The width of the hurdles shall be from 1.18m to 1.20m. The maximum length of the base shall be 0.70m. The total weight of the hurdles shall be not less than 10kg.

4. The height of the top bar shall be 70mm  $\pm$  5mm. The thickness of this bar should be between 10mm and 25mm, and the top edges should be rounded. The bar should be firmly fixed at the extremities.
5. The top bar should be painted with white and black stripes, or with other strong distinctive contrasting colours (and also in contrast with the surrounding environment), such that the lighter stripes, which should be at least 0.225m wide are on the outside. It shall be coloured so as to be visible to all sighted athletes.

6. All races shall be run in lanes and each athlete shall go over each hurdle and keep to their own lane throughout. Failure to do so will result in a disqualification, unless Rule 17.4 applies.

In addition, an athlete shall be disqualified, if:

- 6.1 their foot or leg is, at the instant of clearance, beside the hurdle (on either side), below the horizontal plane of the top of any hurdle; or
- 6.2 they knock down or displace any hurdle by hand, body or the upper side of the lead leg; or
- 6.3 they directly or indirectly knock down or displace a hurdle in their or in another lane in such a manner that there is effect or obstruction upon any other athlete(s) in the race, and/or another rule is also infringed.

*Note: Provided that this Rule is otherwise observed, and the hurdle is not displaced or its height lowered in any manner including tilting in any direction, an athlete may go over the hurdle in any manner.*

The requirement to go over each hurdle should not be read as requiring the athlete to go over each hurdle in their own lane - provided always the intention of Rules 17.3 and 17.4 of the Technical Rules is followed. But if an athlete knocks down or displaces a hurdle in another lane and thereby affects the progress of another athlete they should be disqualified. Situations when an athlete knocks down or displaces a hurdle in another lane should be interpreted in a logical way. For example, an athlete who knocks down or displaces a hurdle in the lane of an athlete who has already gone over that hurdle, should not necessarily be disqualified unless they otherwise infringe the Rules, i.e. by moving to an inside lane on the bend or having their foot or leg, at the instant of clearance, beside the hurdle (on either side), below the horizontal plane of the top of any hurdle. The intent of this Rule is to make it clear that an athlete who in making such action affects another athlete should be considered for disqualification.

Referees and Umpires must nonetheless be alert and be sure that each athlete has kept to their own lane. Additionally, it is common in hurdle races that athletes stretch their arms widely while going over the hurdle,

thus hitting or hampering the athlete in the next lane. This can best be noticed by Umpires standing or a video camera being placed head-on to the athletes. In this regard, Rule 17.2 of the Technical Rules may be applied.

Rule 22.6.1 of the Technical Rules applies to both the athlete’s “lead” and “trail” legs.

“Knocking down” a hurdle does not in itself result in disqualification. The previous reference in the Rule to deliberately knocking down a hurdle has been removed. In Rule 22.6.2, it is replaced by some more objective factors to be considered by the Referee. The most obvious example is where the athlete uses his hand but could also be for example by his chest if he “ran through” the hurdle. It should be noted that the reference to “the upper side of the lead leg” means any part of the front side of the lead leg, not only the part above the knee.

In relation to the Note, it will mainly be relevant to competitions at a lower level but is nonetheless applicable to all. Essentially, it permits an athlete, often one who has fallen or lost their stride pattern, to for example place their hands on the hurdle and “climb over”.

7. Except as provided in Rules 22.6.1 and 22.6.2 of the Technical Rules, the knocking down of hurdles shall not result in disqualification nor prevent a Record being made.

### RULE T22 (168) S 1 UKA SUPPLEMENT HURDLES SPECIFICATIONS

Distance of race	Height of hurdle	Distance to 1st flight	Distance between flights	Distance to finish	No of hurdles	Track Marking Colour
------------------	------------------	------------------------	--------------------------	--------------------	---------------	----------------------

#### MEN’S EVENTS

Under 17 (100m 2.7kg Toppling Weight; 400m: 3.6kg Toppling Weight)

100m	.914m	13.0m	8.5m	10.5m	10	Yellow
400m	.840m	45.0m	35.0m	40.0m	10	Green

WORLD ATHLETICS AND UKA TECHNICAL RULES 2020 EDITION

Distance of race	Height of hurdle	Distance to 1st flight	Distance between flights	Distance to finish	No of hurdles	Track Marking Colour
------------------	------------------	------------------------	--------------------------	--------------------	---------------	----------------------

Under 15 (2.7kg Toppling Weight)

80m	.840m	12.0m	8.0m	12.0m	8	Black
-----	-------	-------	------	-------	---	-------

Under 13 (2.7kg Toppling Weight)

75m	.762m	11.5m	7.5m	11.0m	8	Orange
-----	-------	-------	------	-------	---	--------

**WOMEN'S EVENTS**

Under 17 (2.7kg Toppling Weight)

80m	.762m	12.0m	8.0m	12.0m	8	Black
300m	.762m	50.0m	35.0m	40.0m	7	Green

Under 15 (2.7kg Toppling Weight)

75m	.762m	11.5m	7.5m	11.0m	8	Orange
-----	-------	-------	------	-------	---	--------

Under 13 (2.7kg Toppling Weight)

70m	.685m	11.0m	7.0m	10.0m	8	Pink
-----	-------	-------	------	-------	---	------

**MASTER'S EVENTS**

Men 35 - 49 (3.6kg Toppling Weight)

110m	.991m	13.72m	9.14m	14.02m	10	Blue
400m	.914m	45.0m	35.0m	40.0m	10	Green

Men 50 - 59 (100m: 3.6kg Toppling Weight; 400m: 2.7kg Toppling Weight)

100m	.914m	13.0m	8.5m	10.5m	10	Yellow
400m	.840m	45.0m	35.0m	40.0m	10	Green

WORLD ATHLETICS AND UKA TECHNICAL RULES 2020 EDITION

Distance of race	Height of hurdle	Distance to 1st flight	Distance between flights	Distance to finish	No of hurdles	Track Marking Colour
------------------	------------------	------------------------	--------------------------	--------------------	---------------	----------------------

Men 60 – 69 (2.7kg Toppling Weight)

100m	.840m	12.0m	8.0m	16.0m	10	
300m	.762m	50.0m	35.0m	40.0m	7	Green

Men 70 – 79 2.7kg Toppling Weight)

80m	.762m	12.0m	7.0m	19.0m	8	
300m	.686m	50.0m	35.0m	40.0m	7	Green

Men 80 and Over 2.7kg Toppling Weight)

80m	.686m	12.0m	7.0m	19.0m	8	
200m	.686m	20.0m	35.0m	40.0m	5	Green

Women 40 – 49 (2.7kg Toppling Weight)

80m	.762m	12.0m	8.0m	12.0m	8	Black
400m	.762m	45.0m	35.0m	40.0m	10	Green

Women 50 – 59 (2.7kg Toppling Weight)

80m	.762m	12.0m	7.0m	19.0m	8	-
300m	.762m	50.0m	35.0m	40.0m	7	Green

Women 60 and over (2.7kg Toppling Weight)

80m	.685m	12.0m	7.0m	19.0m	8	-
-----	-------	-------	------	-------	---	---



Women 60 – 69 (2.7kg Toppling  
Weight)

300m	.685m	50.0m	35.0m	40.0m	7	Green
------	-------	-------	-------	-------	---	-------

Women 70 and over (2.7kg Toppling  
Weight)

200m	.685m	20.0m	35.0m	40.0m	5	-
------	-------	-------	-------	-------	---	---

**INDOOR  
MEN'S EVENTS**

Distance of race	Height of hurdle	Distance to 1st flight	Distance between flights	Distance to finish	No of hurdles	Track Marking Colour
------------------	------------------	------------------------	--------------------------	--------------------	---------------	----------------------

Under 17 (2.7kg Toppling Weight)

60m	.914m	13.0m	8.5m	10.5m	5	
-----	-------	-------	------	-------	---	--

Under 15 (2.7kg Toppling Weight)

60m	.840m	12.0m	8.0m	16.0m	8	
-----	-------	-------	------	-------	---	--

Under 13 (2.7kg Toppling Weight)

60m	.762m	11.5m	7.5m	18.5m	5	
-----	-------	-------	------	-------	---	--

**WOMEN'S EVENTS**

Under 17 (2.7kg Toppling Weight)

60m	.762m	12.0m	8.0m	16.0m	5	
-----	-------	-------	------	-------	---	--

Under 15 (2.7kg Toppling Weight)

60m	.762m	11.5m	7.5m	18.5m	5	
-----	-------	-------	------	-------	---	--

Under 13 (2.7kg Toppling Weight)

60m	.685m	11.0m	7.0m	21.0m	5	
-----	-------	-------	------	-------	---	--

**MASTERS' EVENTS**

Men 35 - 49 (3.6kg Toppling Weight)

60m	.991m	13.72m	9.14m	9.72m	5	
-----	-------	--------	-------	-------	---	--

Men 50 - 59 (3.6kg Toppling Weight)

60m	.914m	13.0m	8.5m	13.0m	5	
-----	-------	-------	------	-------	---	--

WORLD ATHLETICS AND UKA TECHNICAL RULES 2020 EDITION

Distance of race	Height of hurdle	Distance to 1st flight	Distance between flights	Distance to finish	No of hurdles	Track Marking Colour
------------------	------------------	------------------------	--------------------------	--------------------	---------------	----------------------

Men 60 – 69 (2.7kg Toppling Weight)

60m	.840m	12.0m	8.0m	16.0m	5
-----	-------	-------	------	-------	---

Men 70 – 79 2.7kg Toppling Weight)

60m	.762m	12.0m	7.0m	20.0m	5
-----	-------	-------	------	-------	---

Men 80 and over 2.7kg Toppling Weight)

60m	.685m	12.0m	7.0m	20.0m	5
-----	-------	-------	------	-------	---

Women 35 – 39 (2.7kg Toppling Weight)

60m	.840m	13.0m	8.5m	13.0m	5
-----	-------	-------	------	-------	---

Women 40 – 49 (2.7kg Toppling Weight)

60m	.762m	12.0m	8.0m	16.0m	5
-----	-------	-------	------	-------	---

Women 50 – 59 (2.7kg Toppling Weight)

60m	.762m	12.0m	7.0m	20.0m	5
-----	-------	-------	------	-------	---

Women 60 and over (2.7kg Toppling Weight)

60m	.685m	12.0m	7.0m	20.0m	5
-----	-------	-------	------	-------	---

*NOTE 1: In each case there shall be a tolerance of .003m above and below the standard height to allow for variation in manufacture.*

*NOTE 2: Due to manufacturing varieties, hurdles up to 1.000m are also acceptable in the U20 110m Hurdles.*

*NOTE 3: Under 17 Men seeking qualification standards for World Athletics U18 Competition are advised to request the appropriate toppling weight to be applied.*

**RULE 23 STEEPLECHASE RACES**

1. The standard distances shall be: 2000m and 3000m.
2. For the 3000m event, there shall be 28 hurdle jumps and 7 water jumps. The distance from the start to the beginning of the first lap shall not include any jumps, the hurdles being removed until the athletes have entered the first lap.
3. For the steeplechase events, there shall be five jumps in a complete lap, with the water jump as the fourth. The jumps should be evenly distributed, so that the distance between the jumps shall be approximately one fifth of the nominal length of the lap.

*Note: Adjustment to the hurdle spacing may be necessary to ensure that safe distances from a hurdle / start line and to the next hurdle are maintained before and after the finish line respectively, as indicated in the World Athletics Track and Field Facilities Manual.*

4. For the 2000m event, there shall be 18 hurdle jumps and 5 water jumps. The first jump is at the third hurdle of a lap. The previous hurdles shall be removed until the athletes have passed them for the first time.

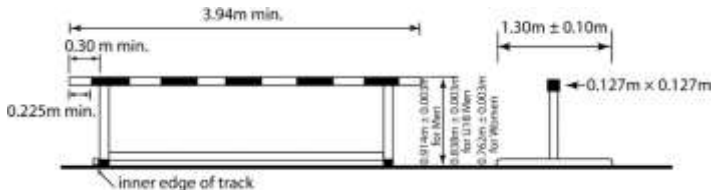
*Note: In the 2000m event, if the water jump is on the inside of the track, the finish line has to be passed twice before the first complete lap with five jumps.*

5. The hurdles shall be  $0.914\text{m} \pm 0.003\text{m}$  high for Senior and U20 men's events,  $0.838\text{m} \pm 0.003\text{m}$  high for U18 men's events and  $0.762\text{m} \pm 0.003\text{m}$  for women's events and shall be at least 3.94m wide.

*NOTE: With effect from 1<sup>st</sup> April 2021, UKA Under 17 Men's competitions will be held using the U18 Men's hurdle specification.*

The section of the top bar of the hurdles, and the hurdle at the water jump, shall be 0.127m square.

The weight of each hurdle shall be between 80kg and 100kg. Each hurdle shall have on either side a base between 1.2m and 1.4m (see Figure (a) Rule 23 of the Technical Rules).



**Figure (a) Rule 23 TR (Rule 169) - Example of a steeplechase hurdle**

The hurdle at the water jump shall be  $3.66\text{m} \pm 0.02\text{m}$  wide, and shall be firmly fixed in or to the pit concrete walls, so that minimal only horizontal movement is possible.

The top bars shall be made of wood or other suitable material and should be painted with white and black stripes, or with other strong distinctive contrasting colours (and also in contrast with the surrounding environment), such that the lighter stripes, which should be at least 0.225m wide, are on the outside and shall be coloured so as to be visible to all sighted athletes.

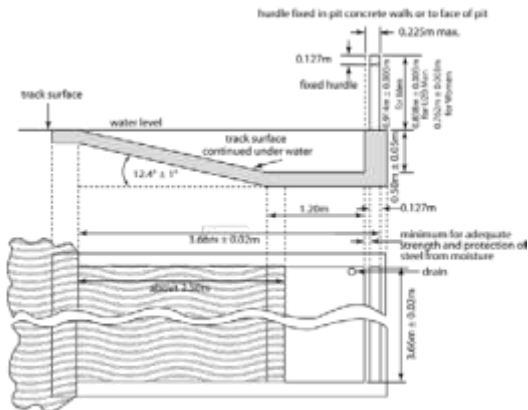
The hurdle shall be placed on the track so that at least 0.30m of the top bar will extend inside the inner edge of the track.

*Note: It is recommended that the first hurdle taken in the race should be at least 5m in width.*

6. The water jump, including the hurdle, shall be  $3.66\text{m} \pm 0.02\text{m}$  in length and the water pit shall be  $3.66\text{m} \pm 0.02\text{m}$  in width.

The bottom of the water pit shall consist of a synthetic surface, or matting, of sufficient thickness to ensure safe landing, and allow for the spikes to grip satisfactorily. The depth of the water closest to the hurdle shall be  $0.50\text{m} \pm 0.05\text{m}$  for approximately 1.20m. From there, the bottom shall have a uniform slope of  $12.4^\circ \pm 1^\circ$  upwards to the level of the track at the farther end of the water pit. At the start of a race, the surface of the water shall be level with the surface of the track within a margin of 20mm.

*Note: Pits to the 2018/19 specifications remain acceptable.*



**Figure (b) Rule 23 TR (Rule 169) - Water jump**

7. Each athlete shall go over or through the water and shall go over each hurdle. Failure to do so will result in a disqualification. In addition, an athlete shall be disqualified, if
  - 7.1 they step to one side or other of the water jump, or
  - 7.2 their foot or leg is, at the instant of clearance, beside the hurdle (on either side), below the horizontal plane of the top of any hurdle.

Provided this Rule is observed, an athlete may go over each hurdle in any manner.

### RULE T23 (169) S 1 UKA SUPPLEMENT STEEPLECHASE RACES

- (1) Seniors, Under 20 and Under 17s are allowed to contest any steeplechase event. Under 15 athletes may compete in Steeplechase races over 1500m and a hurdle height of 0.762m on the understanding that this will be a development event.  
With effect from 1<sup>st</sup> April 2022, Under 17 Men's races will use hurdles  $0.838m \pm 0.003m$  high.

(2) The standard events are:

Distance of Race	Number of Hurdles	Number of Water Jumps	Distance from start to first hurdle
3000m	28	7	257.8m
2000m	18	5	203.8m
1500m	13	3	255.8m

*NOTE: Owing to the water jump having to be constructed on the arena inside or outside the track, thereby shortening or lengthening the normal distance of the lap, it is not possible to lay down any rule specifying the exact length of the lap or state precisely the position of the water jump.*

It should be borne in mind that there must be enough distance from the starting line to the first hurdle to prevent competitors from overcrowding and there should be approximately 62.2m from the last hurdle to the finish line.

The water jump should be, where possible, the fourth jump in each lap. If necessary, the finish line should be moved to another part of the track.

(3) The following measurements are given as a guide and any adjustments necessary should be made by lengthening or shortening the distance at the starting point of the race. It is assumed that a lap of 400 metres has been shortened by 6 metres by constructing the water jump inside the track.

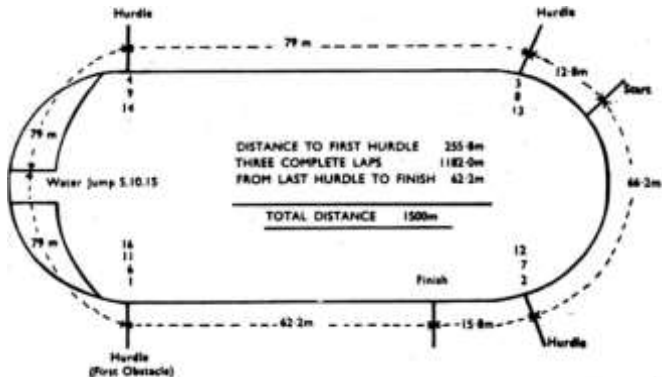
(i) 3000 Metres

Distance from starting point to commencement of first lap, to be run without jumps	242.0m
Distance from commencement of 1st lap to 1st hurdle	15.8m
From 1st to 2nd hurdle	79.0m
From 2nd to 3rd hurdle	79.0m
From 3rd hurdle to water jump	79.0m
From water jump to 4th hurdle	79.0m
From 4th hurdle to finishing line	

7 laps of 394m =	62.2_m_
plus	2758.0m
	242.0m
	3000m





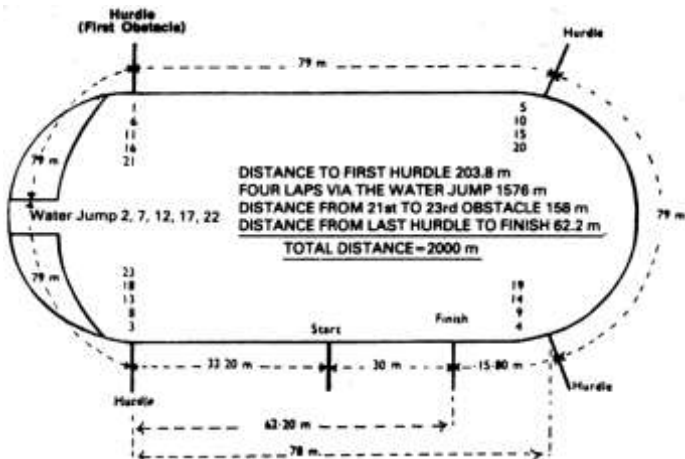


(i) 2000 Metres

(if the course is laid out with a lap of 394m.)

(i) 1500 Metres

(if the course is laid out with a lap of 394m.)



**(4) Masters'**

Men 35 – 59	3000m	.914m	28 barriers and 7 water jumps
Men 60+	2000m	.762m	18 barriers and 5 water jumps
Women 35+	2000m	.762m	18 barriers and 5 water jumps

**RULE 24 RELAY RACES**

1. The standard distances shall be: 4 × 100m, 4 × 200m, 100m-200m-300m-400m Medley Relay (Medley Relay), 4 × 400m, 4 × 800m, 1200m-400m-800m-1600m **Distance** Medley Relay (Distance Medley Relay), 4 × 1500m.

*Note: The Medley Relay may be run with the legs in a different order in which case the appropriate adjustments should be made to the application of Rules 24.14, 24.18, 24.19 and 24.20 of the Technical Rules.*

2. Lines 50mm wide shall be drawn across the track to mark the start of each leg distance (scratch line).
3. In the 4 x 100m and the 4 x 200m relays, and for the first and second changes in the Medley Relay, each takeover zone shall be 30m long, of which the scratch line is 20m from the start of the zone. For the third change in the Medley Relay and in the 4 x 400m and longer relays each takeover zone shall be 20m long of which the scratch line is the centre. The zones shall start and finish at the edges of the zone lines nearest the start line in the running direction. For each takeover conducted in lanes, a designated official shall ensure that the athletes are correctly placed in their takeover zone. The designated official shall also ensure that Rule 24.4 of the Technical Rules is observed.

The Umpires must ensure that each athlete from each team takes their position in the correct lanes or position. The Starter's Assistants will be responsible for the positioning of the first runners and for ensuring that each is supplied with a baton. They may also be assigned to assist at any takeover zones which subsequently occur at the start line. Chief Umpires for each takeover zone and the umpires placed at their disposal will be responsible for the positioning of the subsequent runners. When all

athletes are correctly positioned the zone Chief Umpire should advise the relevant other officials by the agreed means of communication – which for major competitions would usually be by radio.

They must also ensure that for all takeovers the outgoing runners' feet are completely inside the zone before they commence their movement which eventuates in the taking of the baton. This movement may not commence at any point outside the zone.

4. When all or the first portion of a Relay Race is being run in lanes, an athlete may place one check-mark on the track within their own lane, by using adhesive tape, maximum 0.05m × 0.40m, of a distinctive colour which cannot be confused with other permanent markings. No other check-mark may be used. The Judges shall direct the relevant athlete(s) to adapt or remove any marks not complying with this Rule. If they do not, the Judges shall remove them.

*Note: Serious cases may further be dealt with under Rule 18.5 of the Competition Rules and Rule 7.2 of the Technical Rules.*

5. The relay baton shall be a smooth hollow tube, circular in section, made of wood, metal or any other rigid material in one piece, the length of which shall be 0.28m to 0.30m. The outside diameter shall be 40mm ± 2mm and it shall not weigh less than 50g. It should be coloured so as to be easily visible during the race.
6. Baton specifications and interaction guidelines:

- 6.1 A baton shall be used for all Relay Races held in the Stadium and shall be carried by hand throughout the race. At least for competitions conducted under paragraphs 1.1, 1.2, 1.3 and 1.6 of the International Competition rule, each baton shall be numbered and of a different colour and may include a timing transponder.

*Note: If possible, the allocation of the colour to each lane or starting order position should be shown on the start list.*

- 6.2 Athletes are not permitted to wear gloves or to place material (other than those permitted by Rule 6.4.3 of the Technical Rules) or substances on their hands in order to obtain a better grip of the baton.

6.3 If dropped, the baton shall be recovered by the athlete who dropped it. They may leave their lane to retrieve it provided that, by doing so, they do not lessen the distance to be covered. In addition, where the baton is dropped in such a way that it moves sideways or forward in the direction of running (including beyond the finish line), the athlete who dropped it, after retrieving it, must return at least to the point where it was last in their hand, before continuing in the race. Provided these procedures are adopted where applicable and no other athlete is impeded, dropping the baton shall not result in disqualification.

If an athlete does not follow this Rule, their team shall be disqualified.

7. The baton shall be passed within the takeover zone. The passing of the baton commences when it is first touched by the receiving athlete and is completed the moment it is in the hand of only the receiving athlete. In relation to the takeover zone, it is only the position of the baton which is decisive. Passing of the baton outside the takeover zone shall result in disqualification.

In determining the position of the baton, it is the whole baton which must be considered.

Umpires must be diligent to ensure that they observe any contact with the baton prior to the baton entering the change-zone. If the outgoing runner even touches the baton prior to the baton being inside the zone, the team will be subject to disqualification. They must also ensure that the baton is only in the hand of the receiving athlete before it “leaves” the takeover zone.

8. Until the moment when the baton is in the hand of only the receiving athlete, Rule 17.3 of the Technical Rules shall be applicable only to the incoming athlete. Thereafter it shall be applicable only to the receiving athlete.

Additionally, athletes before receiving and/or after handing over the baton, should keep in their lanes or maintain position until the course is clear to avoid obstruction to other athletes. Rules 17.3 and 17.4 of the Technical Rules shall not apply to these athletes. If, however, an

athlete impedes a member of another team, including by running out of position or lane, Rule 17.2 of the Technical Rules shall be applied.

9. If during the race an athlete takes or picks up the baton of another team, their team shall be disqualified. The other team should not be penalised unless an advantage is obtained.
10. Each member of a relay team may run one leg only. Any four athletes from among those entered for the competition, whether for that or any other event, may be used in the composition of the relay team for any round. However, once a relay team has started in a competition, up to a total of four additional athletes may be used as substitutes in the composition of the team. If a team does not follow this Rule, it shall be disqualified.
11. The composition of a team and the order of running for a relay shall be officially declared no later than one hour before the published first call time (the time by which the athletes must be present in the Call Room) for the first heat of each round of the competition. Further alterations must be verified by a medical officer appointed by the Organisers and may be made only until the final call time (the time at which the athletes are listed to depart the Call Room) for the particular heat in which the team is competing. The team shall compete as named and in the declared order. If a team does not follow this Rule, it shall be disqualified.
12. The 4 × 100m race shall be run entirely in lanes.
13. The 4 × 200m race may be run in any of the following ways:
  - 13.1 where possible, entirely in lanes (four bends in lanes),
  - 13.2 in lanes for the first two legs, as well as that part of the third leg up to the nearer edge of the breakline described in Rule 17.5 of the Technical Rules, where athletes may leave their respective lanes (three bends in lanes),
  - 13.3 in lanes for the first leg up to the nearer edge of the breakline described in Rule 17.5 of the Technical Rules, where athletes may leave their respective lanes (one bend in lanes).

*Note: Where not more than four teams are competing and option 1 is not possible, option 3 should be used.*
14. The Medley Relay race should be run in lanes for the first two legs, as well as that part of the third leg up to the nearer edge of the

breakline described in Rule 17.5 of the Technical Rules, where athletes may leave their respective lanes (two bends in lanes).

15. The 4 × 400m race may be run in either of the following ways:
  - 15.1 in lanes for the first leg, as well as that part of the second leg up to the nearer edge of the breakline described in Rule 17.5 of the Technical Rules, where athletes may leave their respective lanes (three bends in lanes);
  - 15.2 in lanes for the first leg up to the nearer edge of the breakline described in Rule 17.5 of the Technical Rules, where athletes may leave their respective lanes (one bend in lanes).

*Note: Where not more than four teams are competing, Rule 24.15.2 should be used.*

16. The 4 × 800m race may be run in either of the following ways:
  - 16.1 in lanes for the first leg up to the nearer edge of the breakline described in Rule 17.5 of the Technical Rules, where athletes may leave their respective lanes (one bend in lanes);
  - 16.2 without the use of lanes.
17. If an athlete does not follow Rule 24.13, 24.14, 24.15 or 24.16.1 of the Technical Rules their team shall be disqualified.
18. The Distance Medley Relay race and the 4 × 1500m race shall be run without the use of lanes.
19. For all takeovers, athletes are not permitted to begin running outside their takeover zones and shall start within the zone. If an athlete does not follow this Rule, their team shall be disqualified.
20. In the Medley Relay, the athletes running the final leg and in the 4 × 400m race, the athletes running the third and fourth legs (or under Rule 24.15.2 of the Technical Rules, the second leg) shall, under the direction of a designated official, place themselves in their waiting position in the same order (inside to out) as the order of their respective team members as they enter the last bend. Once the incoming athletes have passed this point, the waiting athletes shall maintain their order, and shall not exchange positions at the beginning of the takeover zone. If an athlete does not follow this Rule, their team shall be disqualified.

*Note: In the 4 × 200m race (if this event is not run entirely in lanes) where the previous leg is not run in lanes, the athletes shall line up in the order of the start list (inside to out).*

21. In any race, when lanes are not being used, including when applicable, in 4 × 200m, the Medley Relay and 4 × 400m, waiting athletes can take an inner position on the track as incoming team members approach, provided they do not jostle or obstruct another athlete so as to impede their progress. In 4 × 200m, the Medley Relay and 4 × 400m, waiting athletes shall maintain the order in accordance with Rule 24.20 of the Technical Rules. If an athlete does not follow this Rule, their team shall be disqualified.
22. In the case of relay events not covered by this Rule, the relevant competition regulations should specify any particular rules that should be applied and the method by which the relay should be conducted.

Chief Umpires must remain at the zone to which they and their Umpires have been assigned. Once the athletes are correctly placed in their lanes and the race has started, zone Chief Umpires and those Umpires assigned to them are responsible for reporting any infringements of both these Rules as well as any other infringements particularly those under Rule 17 of the Technical Rules.

**RULE T24 (170) S 1 UKA SUPPLEMENT**

**RELAY RACES**

- (1) On completion of the final leg the baton is to be handed to an official by the last runner. It is not to be dropped or thrown from the hand. Failure to comply with this instruction may lead to disqualification. (See also Rule T7)
- (2) The 4 x 300m Relay uses the 800m start line with the first leg being run in lanes until the break line described in Rule T17.5.1 (one bend in lanes).

The takeover zones for the 2nd, 3rd and 4th legs will be 30 metres, with no acceleration permitted (Rule T24.19).

Athletes for the 2nd, 3rd and 4th legs will be lined up by a designated official in the order (inside to out) of their respective team members as they enter the last bend (Rule T24.20).



## SECTION III – FIELD EVENTS

### RULE 25 GENERAL CONDITIONS – FIELD EVENTS

#### PRACTICE TRIALS AT THE COMPETITION AREA

1. At the competition area and before the beginning of the event, each athlete may have practice trials. In the case of throwing events, the practice trials will be in draw order and always under the supervision of the Judges.

Whilst in the past the Rules specified that there should be two practice trials for each athlete in throwing events, there is currently no such specification. Rule 25.1 of the Technical Rules should be interpreted as allowing whatever number of practice trials that may be included in the warm-up time available. Whilst for major events, two remains a standard practice, this is regarded as a minimum and should time be available and some or all of the athletes request additional practice trials, this can be permitted.

2. Once a competition has begun, athletes are not permitted to use, for practice purposes, as appropriate,
  - 2.1 the runway or take-off area;
  - 2.2 vaulting poles;
  - 2.3 implements;
  - 2.4 the circles or the ground within the sector with or without implements.

The application of this Rule should not prevent an athlete from touching, preparing or taping their vaulting pole or their selected implement in readiness for their trial provided that it does not endanger, delay or obstruct another athlete or other person. It is particularly important that the Judges interpret this Rule reasonably so as to ensure the competition proceeds in an efficient manner and the athlete is able if they so choose to take their trial immediately their time begins.

#### MARKERS

3. Markers, as follows:
  - 3.1 In all Field Events where a runway is used, markers shall be placed alongside it, except for High Jump where the markers

can be placed on the runway. An athlete may use one or two markers (supplied or approved by the Organisers) to assist them in their run-up and take-off. If such markers are not supplied, they may use adhesive tape but not chalk or similar substance nor anything which leaves indelible marks.

- 3.2 For throws made from a circle, an athlete may use one marker only. This marker may be placed only on the ground in the area immediately behind or adjacent to the circle but not on any lines or in the landing sector. It must be temporary, in position only for the duration of each athlete's own trial and shall not impair the view of the Judges. No personal markers may be placed in or beside the landing area.

*Note: Each marker shall be composed of a single piece only.*

- 3.3 For Pole Vault, the Organisers should place suitable and safe distance markers beside the runway at each 0.5m between the points 2.5m to 5m from the "zero" line and at each 1.0m from the 5m to the 18m point.

- 3.4 The Judges shall direct the relevant athlete to adapt or remove any marks not complying with this Rule. If they do not, the Judges shall remove them.

*Note: Serious cases may further be dealt with under Rule 18.5 of the Competition Rules and Rule 7.2 of the Technical Rules.*

If the ground is wet, the adhesive tape can be fixed to the ground by drawing pins of several colours.

The requirement for each marker to be a single piece should be interpreted sensibly by the Referee. If for example the manufacturer has used two pieces connected to make a single structure which is intended to be used that way, it should be allowed. Similarly, if an athlete chooses to place both their markers in the same place or, in the case of the High Jump, an athlete who tears the tape, they are given into one or more pieces to make a single marker of a different shape to stand out more clearly, these should also be acceptable.

Rule 25.3.3 of the Technical Rules is designed to assist athletes and their coaches in determining their take-off points and the progress on the runway. There is no set concept as to how they should be constructed or look – with Organisers and Referees having discretion in interpreting what is acceptable and fair within the intention of the Rule in each particular competition environment.

## **RULE T25 (180) S 1 UKA SUPPLEMENT PRACTICE TRIALS**

### **Practice Trials at The Competition Area**

In the case of practice trials for throwing events the judges shall have the power to alter the order of the trials.

*NOTE: In the Long and Triple Jumps athletes may request that a line be laid down alongside the runway, using tape which is a maximum of 5cm in width and 10cm in length. For the Long & Triple Jumps, this line is to be placed at 3m from the scratch line. If more than one take-off board is to be used for the Triple Jump, it shall only be placed for the board further (furthest) from the landing area.*

### **PERFORMANCE MARKERS AND WIND SOCKS**

4. Performance Markers and Wind Socks, as follows:
  - 4.1 A distinctive flag or marker may be provided to mark the existing World Record and, when appropriate, the existing Area, National or Meeting Record.
  - 4.2 One or more wind sock(s) should be placed in an appropriate position in all jumping events, Discus Throw and Javelin Throw, to show the athletes the approximate direction and strength of the wind.

### **COMPETING ORDER AND TRIALS**

5. Except where Rule 25.6 of the Technical Rules applies, the athletes shall compete in an order drawn by lot.  
If any athlete by their own decision makes a trial in an order different from that previously determined, Rule 18.5 of the Competition Rules and Rule 7.2 of the Technical Rules shall be applied. In the case of a warning, the result of the trial (valid or failure) will stand. If there is a Qualification Round, there shall be a fresh drawing of lot for the final.

**RULE T25 (180) S 2 UKA SUPPLEMENT**  
**ORDER OF COMPETING**

The Judges shall have the power to alter the order of competing.

6. Except for the High Jump and Pole Vault, no athlete shall have more than one trial recorded in any one round of trials of the competition. In all Field Events, except for the High Jump and Pole Vault, where there are more than eight athletes, each athlete shall be allowed three trials and the eight athletes with the best valid performances shall be allowed three additional trials, unless the applicable regulations provide otherwise.

In the case of the last qualifying place, if two or more athletes have the same best performances, Rule 25.22 of the Technical Rules shall be applied. If it is thus determined that there has been a tie, the tying athletes shall be allowed any additional trials, permitted by the applicable regulations.

Where there are eight athletes or fewer, each athlete shall be allowed six trials, unless the applicable regulations provide otherwise. If more than one fail to achieve a valid trial during the first three rounds of trials, such athletes shall compete in subsequent rounds of trials before those with valid trials, in the same relative order according to the original draw.

In both cases:

- 6.1 the competing order for any subsequent rounds of trials shall be in the reverse ranking order recorded after the first three rounds of trials, unless the applicable regulations provide otherwise;
- 6.2 when the competing order is to be changed and there is a tie for any position, those tying shall compete in the same relative order according to the original draw.

*Note (i): For Vertical Jumps, see Rule 26.2 of the Technical Rules.*

*Note (ii): If one or more athlete(s) is permitted by the Referee to continue in a competition “under protest” in accordance with Rule 8.5 of the Technical Rules, such athletes shall compete in all subsequent rounds of trials before all others continuing in the competition and if more than one, in the same relative order according to the original draw.*

*Note (iii): The regulations of the relevant governing body may specify the number of trials (provided it is no more than six) and the number of athletes which may progress to each additional round of trials after the third.*

*Note (iv): The regulations of the relevant governing body may specify that the competing order be changed again after any further round of trials after the third.*

## **RULE T25 (180) S 3 UKA SUPPLEMENT NUMBER OF TRIALS**

The competition may be decided by each competitor being allowed from three to six trials with the number, order and method of qualification determined according to competition regulations governing that event.

### **RECORDING OF TRIALS**

7. Except in High Jump and Pole Vault, a valid trial shall be indicated by the measurement taken.  
For the standard abbreviations and symbols to be used in all other cases, see Rule 25.4 of the Competition Rules.

### **COMPLETION OF TRIALS**

8. The Judge shall not raise a white flag to indicate a valid trial until a trial is completed. The Judge may reconsider a decision if they believe they raised the incorrect flag.  
The completion of a valid trial shall be determined as follows:
  - 8.1 in the case of Vertical Jumps, once the judge has determined that there is no failure according to Rules 27.2, 28.2 or 28.4 of the Technical Rules;
  - 8.2 in the case of Horizontal Jumps, once the athlete leaves the landing area in accordance with Rule 30.2 of the Technical Rules;
  - 8.3 in the case of throwing events, once the athlete leaves the circle or runway in accordance with Rule 32.17 of the Technical Rules.

### **QUALIFICATION ROUND**

9. A Qualification Round shall be held in Field Events in which the number of athletes is too large to allow the competition to be

conducted satisfactorily in a single round (final). When a Qualification Round is held, all athletes shall compete in, and qualify through, that round except that the relevant governing body may, for one or more events, authorise the conduct of additional qualification round(s) either at the same or at one or more earlier competition(s) to determine some or all of the athletes who shall be entitled to participate and in which round of the competition. Such procedure and any other means (such as achieving entry standards during a specified period, by specified placing in a designated competition or by rankings) by which an athlete is entitled to participate, and in which round of the competition, shall be set out in the regulations for each competition.

Performances accomplished in a Qualification Round or additional preliminary qualification round(s) shall not be considered as part of the final.

10. The athletes shall normally be divided into two or more groups such that the groups are of approximately equal strength and whenever possible so that representatives of each Member or team shall be placed in different groups. Unless there are facilities for the groups to compete at the same time and under the same conditions, each group should start its practice trials immediately after the previous group has finished.
11. It is recommended that, in competitions of more than three days, a rest day be provided between Qualifying Rounds and the finals in the vertical jumping events.
12. The conditions for qualifying, the qualifying standard and the number of athletes in the final, shall be decided by the Technical Delegate(s). If no Technical Delegate(s) have been appointed, the conditions shall be decided by the Organisers. For competitions conducted under paragraphs 1.1, 1.2, 1.3 and 1.6 of the International Competition definition, there should be at least 12 athletes in the final unless otherwise provided in the regulations for the competition.
13. In a Qualifying Round, apart from the High Jump and the Pole Vault, each athlete shall be allowed up to three trials. Once an athlete has achieved the qualifying standard, they shall not continue in the Qualifying Round.

14. In a Qualifying Round for the High Jump and the Pole Vault, the athletes, not eliminated after three consecutive failures, shall continue to compete according to Rule 26.2 of the Technical Rules (including passing a trial) until the end of the last trial at the height set as the qualifying standard, unless the number of athletes for the final has been reached as defined in Rule 25.12 of the Technical Rules. Once it is determined that an athlete will be in the final, they shall not continue in the Qualifying Round.
15. If no athletes, or fewer than the required number of athletes, achieve the pre-set qualifying standard, the group of finalists shall be expanded to that number by adding athletes according to their performances in the Qualifying Round. In the case of the last qualifying place, if two or more athletes have the same best performances in the overall results of the competition, Rule 25.22 or 26.8 of the Technical Rules as appropriate shall be applied. If it is thus determined that there has been a tie, the tying athletes shall be placed in the final.
16. When a Qualifying Round for the High Jump and Pole Vault is held in two simultaneous groups, it is recommended that the bar be raised to each height at the same time in each group.

It is important when seeding High Jump and Pole Vault qualifying groups that the requirements of Rule 25.10 and 25.16 of the Technical Rules are both observed. The Technical Delegates and the ITO/Referee must follow closely the progress of the qualifying rounds of the High Jump and the Pole Vault to ensure that, on the one hand, the athletes must jump, as long as they are not eliminated under Rule 26.2 of the Technical Rules until the qualifying standard has been reached (unless the number of athletes for the final has been reached as defined in Rule 25.12 of the Technical Rules) and, on the other hand, any tie between athletes in the overall standings in the two groups is resolved according to Rule 26.8 of the Technical Rules. Close attention must also be kept to the application of Rule 25.14 of the Technical Rules to ensure that athletes do not unnecessarily continue in the competition once it is certain that they will be in the final regardless of what may happen to the other athletes continuing to compete in the Qualification Round.

**TIME ALLOWED FOR TRIALS**

17. The official responsible shall indicate to an athlete that all is ready for the trial to begin, and the period allowed for this trial shall commence from that moment.

For the Pole Vault, the time shall begin when the crossbar has been adjusted according to the previous wishes of the athlete. No additional time will be allowed for further adjustment.

If the time allowed elapses after an athlete has started their trial, that trial should not be disallowed.

If after the time for a trial has begun, an athlete decides not to attempt that trial, it shall be considered a failure once that period allowed for the trial has elapsed.

The following times shall not be exceeded. If the time is exceeded, unless a determination is made under Rule 25.18 of the Technical Rules, the trial shall be recorded as a failure:

**INDIVIDUAL EVENTS**

	High Jump	Pole Vault	Other
More than 3 athletes (or for the very first trial of each athlete)	1 min	1 min	1 min
2 or 3 athletes	1.5 min	2 min	1 min
1 athlete	3 min	5 min	-
Consecutive trials	2 min	3 min	2 min

**COMBINED EVENTS**

	High Jump	Pole Vault	Other
More than 3 athletes (or for the very first trial of each athlete)	1 min	1 min	1 min
2 or 3 athletes	1.5 min	2 min	1 min
1 athlete	2 min	3 min	-
Consecutive trials	2 min	3 min	2 min

*Note (i): A clock which shows the remaining time allowed for a trial should be visible to an athlete. In addition, an official shall raise and keep raised, a yellow flag, or otherwise indicate, during the final 15 seconds of the time allowed.*



*Note (ii): In the High Jump and Pole Vault, any change in the time period allowed for a trial, except the time specified for consecutive trials, shall not be applied until the bar is raised to a new height. In the other Field Events, except for the time specified for consecutive trials, the time limit allowed will not change.*

*Note (iii): When calculating the number of athletes remaining in the competition, this shall include those athletes who could be involved in a jump off for first place.*

*Note (iv): When only one athlete (who has won the competition) remains in High jump or Pole Vault and is attempting a World Record or other record relevant to the competition, the time limit shall be increased by one minute beyond those set out above.*

Whilst the Judges should always use a system which notifies or calls the next athlete who is to take their trial plus the one who is to follow, this is essential when the time allowed for an athlete to take their trial is one minute. They must also ensure that the competition area is completely ready for the next trial before calling the athlete and then starting the clock. The Judges, and the Referee in particular, must be fully aware of the current competition environment, including direction from Event Presentation, when deciding when to start the clock or to “time out” and call a failure.

Particular circumstances which should be taken into account are the availability of the runway for an athlete’s trial in High Jump and Javelin Throw (when Track Events are being held simultaneously in the same competition area) and the distance for athletes to walk to and through the cage to reach the circle to take their trial in Discus Throw and Hammer Throw.

To be clear, the time limit will not change in the final round of any horizontal Field Event, once only 2 or 3 athletes remain to take their trials. The 1 minute time limit only applies when a Horizontal Field Event has only 2 or 3 athletes on the original start list (except for the very first trial of each athlete).

## **REPLACEMENT TRIALS**

18. If, for any reason beyond their control, an athlete is hampered in a trial and is unable to take it, or the trial cannot be correctly recorded,

the Referee shall have the authority to award them a replacement trial or to re-set the time either partially or in full.

No change in the order shall be permitted. A reasonable time shall be allowed for any replacement trial according to the particular circumstances of the case. In cases when the competition has progressed before the replacement trial is awarded, it should be taken before any other subsequent trials are then made.

There are several situations in which it may be appropriate for an athlete to be given a replacement trial including where because of procedural or technical failure a trial is not measured and it is not possible for a re-measurement to be accurately made. Whilst this should be avoided by good systems and backups, with technology being used more and more provision needs to be made for when things do go wrong. As no change in the competition order should be permitted (unless the problem is not immediately discovered and the competition has continued), the Referee must decide how long should be allowed for the replacement trial taking into account the specific circumstances of each particular case.

#### **ABSENCE DURING COMPETITION**

19. An athlete may not leave the immediate area of the event during the progress of the competition, unless they have the permission of, and is accompanied by, an official. If possible, a warning should be given first, but for subsequent instances or in serious cases the athlete shall be disqualified.

*NOTE: Should there be insufficient Officials available, then an Official may grant an athlete permission to leave the area unaccompanied.*

#### **CHANGE OF COMPETITION AREA OR TIME**

20. The Technical Delegate(s) or appropriate Referee shall have the authority to change the place or time of the competition if, in their opinion, the conditions justify it. Such a change should be made only after a round of trials has been completed.

*Note: Neither the wind strength nor its change of direction is sufficient condition to change the place nor time of the competition.*

The phrase "round of trials" instead of "rounds" is designed to ensure a clear difference between a "round of trials" within a Field Event

competition and a "round of the competition" (i.e. a Qualification Round or a Final).

If the conditions make it impossible to complete a round of trials before a change of place or time is made, the Technical Delegate (through the Referee) or Referee should normally void those trials already completed in that round of trials and recommence the competition at the beginning of that round of trials. See also Rule 11.3 of the Technical Rules.

## **RESULT**

21. Each athlete shall be credited with the best of all their trials, including, in the case of High Jump and Pole Vault, those achieved in resolving a tie for first place.

## **TIES**

22. Except for the High Jump and Pole Vault, the second best performance of the athletes having the same best performances shall determine whether there has been a tie. Then, if necessary, the third best, and so on. If the athletes are still equal following the application of this Rule 25.22, it shall be determined to be a tie. Except in Vertical Jumps, in the case of a tie for any place, including first place, the tie shall remain.

*Note: For Vertical Jumps, see Rules 26.8, 26.9 of the Technical Rules.*

## A. VERTICAL JUMPS

### **RULE 26 GENERAL CONDITIONS – VERTICAL JUMPS**

1. Before the competition begins, the Referee or the Chief Judge shall announce to the athletes the starting height and the subsequent heights to which the bar will be raised at the end of each round of trials, until there is only one athlete remaining having won the competition, or there is a tie for first place. (For Combined Events, see Rule 39.8.4 of the Technical Rules).

#### **TRIALS**

2. An athlete may commence jumping / vaulting at any height previously announced by the Referee or Chief Judge and may jump / vault at their own discretion at any subsequent height. Three consecutive failures, regardless of the height at which any of such failures occur, disqualify from further jumping / vaulting except in the case of a tie for first place.

The effect of this Rule is that an athlete may pass their second or third trial at a particular height (after failing first or second time) and still jump / vault at a subsequent height.

If an athlete passes a trial at a certain height, they may not make any subsequent trial at that height, except in the case of a jump-off for first place.

In the case of the High Jump and Pole Vault, if an athlete is not present when all other athletes who are present have completed the competition, the Referee shall deem that such athlete(s) has abandoned the competition, once the period for one further trial has elapsed.

3. Even after all the other athletes have failed, an athlete is entitled to continue jumping until they have forfeited their right to compete further.
4. Unless there is only one athlete remaining and they have won the competition:
  - 4.1 the bar shall never be raised by less than 2cm in the High Jump and 5cm in the Pole Vault after each round of trials; and
  - 4.2 the increment of the raising of the bar shall never increase.

These Rules 26.4.1 and 26.4.2 of the Technical Rules shall not apply once the athletes still competing all agree to raise it to a World Record (or other record relevant to the competition) height directly. After an athlete has won the competition, the height or heights to which the bar is raised shall be decided by the athlete, in consultation with the relevant Judge or Referee.

*Note: This Rule does not apply for a Combined Events Competition.*

## **HEIGHT MEASUREMENT**

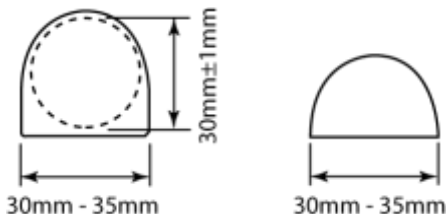
5. In all vertical jumping events, measurements shall be made, in whole centimetres, perpendicularly from the ground to the lowest part of the upper side of the bar.
6. Any measurement of a new height shall be made before athletes attempt such height. A re-measurement should be made if the bar has been substituted. In all cases of Records, the Judges shall also re-check the measurement before each subsequent Record attempt if the bar has been touched since last measured.

## **CROSSBAR**

7. The crossbar shall be made of fibre-glass, or other suitable material but not metal, circular in cross-section except for the end pieces. It shall be coloured so as to be visible to all sighted athletes. The overall length of the crossbar shall be  $4.00\text{m} \pm 0.02\text{m}$  in the High Jump and  $4.50\text{m} \pm 0.02\text{m}$  in Pole Vault. The maximum weight of the crossbar shall be 2kg in the High Jump and 2.25kg in Pole Vault. The diameter of the circular part of the crossbar shall be  $30\text{mm} \pm 1\text{mm}$ . The crossbar shall consist of three parts - the circular bar and two end pieces, each 30mm-35mm wide and 0.15m-0.20m long for the purpose of resting on the supports of the uprights. These end pieces shall be circular or semi-circular with one clearly defined flat surface on which the bar rests on the crossbar supports. This flat surface may not be higher than the centre of the vertical cross section of the crossbar. The end pieces shall be hard and smooth. They shall not be of or covered with rubber or any other material which has the effect of increasing the friction between them and the supports.

The crossbar shall have no bias and, when in place, shall sag a maximum of 20mm in the High Jump and 30mm in Pole Vault.

Control of elasticity: Hang a 3kg weight in the middle of the crossbar when in position. It may sag a maximum of 70mm in the High Jump and 0.11m in Pole Vault.



**Figure Rule 26 TR (Rule 181) - Alternative ends for crossbar**

## PLACINGS

8. If two or more athletes clear the same final height, the procedure to decide the places will be the following:
  - 8.1 The athlete with the lowest number of jumps at the height last cleared shall be awarded the higher place.
  - 8.2 If the athletes are equal following the application of Rule 26.8.1 of the Technical Rules, the athlete with the lowest total of failures throughout the competition up to and including the height last cleared, shall be awarded the higher place.
  - 8.3 If the athletes are still equal following the application of Rule 26.8.2 of the Technical Rules, the athletes concerned shall be awarded the same place unless it concerns the first place.
  - 8.4 If it concerns the first place, a jump-off between these athletes shall be conducted in accordance with Rule 26.9 of the Technical Rules, unless otherwise decided, either in advance according to the regulations applying to the competition, or during the competition but before the start of the event by the Technical Delegate(s) or the Referee if no Technical Delegate has been appointed. If no jump-off is

carried out, including where the relevant athletes at any stage decide not to jump further, the tie for first place shall remain.

*Note: This Rule 26.8.4 does not apply for a Combined Events Competition.*

There are a number of ways in which a jump-off may be terminated:

- a. by provision in advance of the competition set out in the regulations;
- b. by decision during the competition by the Technical Delegate (or Referee if there is no Technical Delegate);
- c. by decision of the athletes not to jump further prior to or at any stage of the jump-off.

Whilst any decision by the Technical Delegate or Referee not to conduct a jump-off should be made before the start of the event, there may be circumstances where this might not be possible such as where conditions at the place of competition make it impossible or undesirable to begin or continue with a jump-off. The Referee could use their powers under Rule 18 of the Competition Rules or Rule 25 of the Technical Rules to deal with this situation. It is emphasised that the athletes may make the decision not to jump further either before or at any stage during the jump-off.

## **JUMP-OFF**

9. Jump-off, as follows:

- 9.1 Athletes concerned must jump at every height until a decision is reached or until all of the athletes concerned decide not to jump further.
- 9.2 Each athlete shall have one jump at each height.
- 9.3 The jump-off shall start at the next height determined in accordance with Rule 26.1 of the Technical Rules after the height last cleared by the athletes concerned.
- 9.4 If no decision is reached the bar shall be raised if more than one athlete concerned were successful, or lowered if all of them failed, by 2cm for the High Jump and 5cm for the Pole Vault.
- 9.5 If an athlete is not jumping at a height, they automatically forfeit any claim to a higher place. If only one other athlete

then remains, they are declared the winner regardless of whether they attempt that height.

### **High Jump - Example**

Heights announced by the Chief Judge at the beginning of competition: 1.75m; 1.80m; 1.84m; 1.88m; 1.91m; 1.94m; 1.97m; 1.99m...

Athlete	Heights							Failures	Jump Off			Pos
	1.75m	1.80m	1.84m	1.88m	1.91m	1.94m	1.97m		1.91m	1.89m	1.91m	
A	O	XO	O	XO	X-	XX		2	X	O	X	2
B	-	XO	-	XO	-	-	XXX	2	X	O	O	1
C	-	O	XO	XO	-	XXX		2	X	X		3
D	-	XO	XO	XO	XXX			3				4

"A", "B", "C" and "D" all cleared 1.88m.

Rules 26.8 and 26.9 of the Technical Rules now come into operation; the Judges add up the total number of failures, up to and including the height last cleared, i.e. 1.88m.

"D" has more failures than "A", "B" or "C", and is therefore awarded fourth place. "A", "B" and "C" are still equal and as this concerns the first place, they shall jump at 1.91m which is the next height after the height last cleared by the athletes concerned.

As all the athletes failed, the bar is lowered to 1.89m for another jump-off. As only "C" failed to clear 1.89m, the two other athletes, "A" and "B" shall have a third jump-off at 1.91m which only "B" cleared and is therefore declared the winner.

When an athlete unilaterally decides to withdraw from a jump-off, the other athlete (if only one remains) will be declared the winner in accordance with Rule 26.9.5 of the Technical Rules. It is not necessary for that athlete to attempt the applicable height. Where more than one athlete remains in the jump-off, the jump-off continues with those athletes, with the athlete who withdrew being placed according to their then finishing place, they having forfeited any right to any higher placing, including first, then remaining.

## **EXTRANEIOUS FORCES**



10. When it is clear that the bar has been displaced by a force not associated with an athlete (e.g. a gust of wind)
  - 10.1 if such displacement occurs after an athlete has cleared the bar without touching it, then the trial shall be considered successful, or
  - 10.2 if such displacement occurs under any other circumstance, a new trial shall be awarded.

## **RULE 27 HIGH JUMP**

### **COMPETITION**

1. An athlete shall take off from one foot.
2. An athlete fails if:
  - 2.1 After the jump, the bar does not remain on the supports because of the action of the athlete whilst jumping; or
  - 2.2 They touch the ground including the landing area beyond the vertical plane through the nearer edge of the crossbar, either between or outside the uprights with any part of their body, without first clearing the bar. However, if when they jump, an athlete touches the landing area with their foot and in the opinion of the Judge, no advantage is gained, the jump for that reason shall not be considered a failure.

*Note: To assist in the implementation of this Rule a white line 50mm wide shall be drawn (usually by adhesive tape or similar material) between points 3m outside of each upright, the nearer edge of the line being drawn along the vertical plane through the nearer edge of the crossbar.*

- 2.3 They touch the crossbar or the vertical section of the uprights when running up without jumping.

### **RUNWAY AND TAKE-OFF AREA**

3. The minimum width of the runway shall be 16m and the minimum length of the runway shall be 15m except in competitions held under paragraphs 1.1, 1.2, 1.3, 1.5 and 1.6 of the International Competition definition, where the minimum length shall be 25m.
4. The maximum overall downward inclination in the last 15m of the runway and take-off area shall not exceed 1:167 (0.6%) along any radius of the semi-circular area centred midway between the

uprights and having the minimum radius specified in Rule 27.3 of the Technical Rules. The landing area should be placed so that the athlete's approach is up the inclination.

*Note: Runways and take-off areas to the 2018/19 specifications remain acceptable.*

5. The take-off area shall be level, or any inclination shall be in accordance with the requirements of Rule 27.4 of the Technical Rules and the World Athletics Track and Field Facilities Manual.

### **APPARATUS**

6. Any style of uprights or posts may be used, provided they are rigid. They shall have supports for the crossbar firmly fixed to them. They shall be sufficiently tall as to exceed the actual height to which the crossbar is raised by at least 0.10m.

The distance between the uprights shall be not less than 4.00m nor more than 4.04m.

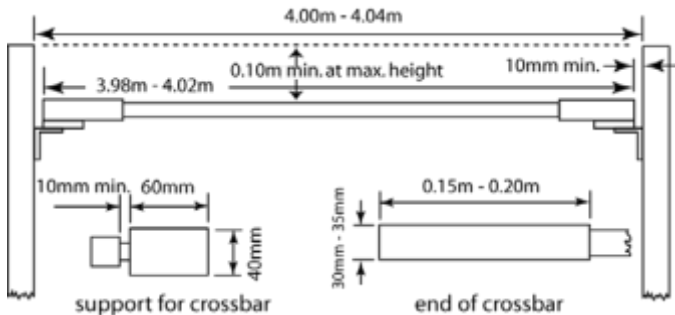
7. The uprights or posts shall not be moved during the competition unless the Referee considers that either the take-off or landing area has become unsuitable.

In such a case, the change shall be made only after a round of trials has been completed.

8. The crossbar supports shall be flat and rectangular, 40mm wide and 60mm long. They shall be firmly fixed to the uprights and immovable during the jump and shall each face the opposite upright. The ends of the crossbar shall rest on them in such a manner that, if the crossbar is touched by an athlete, it will easily fall to the ground, either forwards or backwards. The surface of the supports shall be smooth.

The supports shall not be of, or covered with, rubber or with any other material which has the effect of increasing the friction between them and the surface of the crossbar, nor may they have any kind of springs.

The supports shall be the same height above the take-off area immediately below each end of the crossbar.



**Figure Rule 27 TR (Rule 182) - High Jump uprights and crossbar**

9. There shall be a space of at least 10mm between the ends of the crossbar and the uprights.

#### LANDING AREA

10. For competitions under paragraphs 1.1, 1.2, 1.3, 1.5 and 1.6 of the International Competition definition, the landing area shall be not smaller than 6m long x 4m wide x 0.7m high behind the vertical plane of the crossbar.

*Note: The uprights and landing area should also be designed so that there is a clearance of at least 0.1m between them when in use, to avoid displacement of the crossbar through a movement of the landing area causing contact with the uprights.*

*UKA Note: The two standards as defined above by World Athletics apply to competition in the UK. High Jump beds of the pre 2020 specification are acceptable.*

For other competitions, the landing area should measure not less than 5m long x 3m wide x 0.7m high.

Team of Officials

For a High Jump event, it is recommended to allocate the available officials as follows:

- a. The Chief Judge will watch over the whole of the event and verify the measurements. They must be provided with two flags - white to indicate if the trial is valid and red if it is a failure. They must place themselves so as to manage two matters in particular:
  - i. Frequently it happens that the cross-bar having been touched by an athlete trembles on the supports. The Chief Judge, depending

on the position of the cross-bar, must decide when the vibrating of the bar must be stopped, and the appropriate flag raised – particularly the special situations as covered in Rule 26.10 of the Technical Rules; and

- ii. Since the athlete may not touch the crossbar, the vertical section of the uprights or ground beyond the vertical plane of the nearer edge of the crossbar it is important to keep a watch on the position of the athlete's feet in situations where when deciding not to complete a trial they run to the side or goes "under" the bar.
- b. Two Judges, one on either side of the landing area and slightly standing back in charge of replacing the crossbar when it falls and assisting the Chief Judge in applying the above Rules.
- c. Judge - a recorder scoring the results sheet and calling each athlete (and the one who is to follow).
- d. Judge in charge of the scoreboard (trial-number-result).
- e. Judge in charge of the clock indicating to the athletes that they have a certain time to take their trial.
- f. Judge in charge of athletes.

*Note (i): This is the traditional setting-up of the officials. In major competitions, where a data system and electronic scoreboards are available, specialised personnel are certainly required. To be clear in these cases, the progress and scoring of a Field Event is followed by both the recorder and by the data system.*

*Note (ii): Officials and equipment must be placed in such a way as not to obstruct the athlete's way nor impede the view of the spectators.*

*Note (iii): A space must be reserved for a wind-sock to indicate the wind direction and strength.*

**RULE 28 POLE VAULT****COMPETITION**

1. Athletes may have the crossbar moved only in the direction of the landing area so that the edge of the crossbar nearest the athlete can be positioned at any point from that directly above the back end of the box to a point 80cm in the direction of the landing area.

An athlete shall, before the competition starts, inform the appropriate official of the position of the crossbar they require for their first trial and this position shall be recorded.

If subsequently an athlete wants to make any changes, they should immediately inform the appropriate official before the crossbar has been set in accordance with their initial wishes. Failure to do this shall lead to the start of their time limit.

*Note: A line, 10mm wide and of distinguishable colour, shall be drawn at right angles to the axis of the runway, in line with the back end of the box ("zero" line). A similar line, up to 50mm wide, shall appear on the surface of the landing area and be prolonged as far as the outside edge of the uprights. The edge of the line nearer to the approaching athlete coincides with the back end of the box.*

2. An athlete fails if:
  - 2.1 after the vault, the bar does not remain on both pegs because of the action of an athlete whilst vaulting; or
  - 2.2 they touch the ground, including the landing area, beyond the vertical plane through the back end of the box with any part of their body or with the pole, without first clearing the bar; or
  - 2.3 after leaving the ground, they place their lower hand above the upper one or moves the upper hand higher on the pole; or
  - 2.4 during the vault, they steady or replace the bar with their hand(s).

*Note (i): It is not a failure if an athlete runs outside the white lines marking the runway at any point.*

*Note (ii) It is not a failure if the pole touches the landing mats, in the course of trial, after properly being planted in the box.*

The following should be noted in applying and interpreting Rule 28.2 of the Technical Rules:

- a the bar must be dislodged because of the action of the athlete "whilst vaulting". So, if the athlete after correctly retrieving their pole (so as not to infringe Rule 28.4 of the Technical Rules) were then to hit the crossbar or the uprights with the pole so that it was dislodged, this would not amount to a failure since it was not because of the action of the athlete whilst vaulting, unless the crossbar was still moving and, as a result, the Judge had not yet raised the white flag;
- b to take into account the effect of Note (ii) as there will be many occasions when the pole on bending will touch the landing area beyond the zero line;
- c to be aware of the possibility that the athlete can actually take-off in such a way that their body or the bend of the pole will penetrate the vertical plane through the zero line but then they return to the runway without attempting to clear the bar. Provided that they have time left for their trial and they did not touch the ground beyond the zero line, they may continue with the trial. This also applies in cases where the athlete during the time for his trial is, for any reason, placing the pole in the box or otherwise through the vertical plane of the zero line and the pole touches the ground beyond the zero line, this is a failure;
- d Judges must take particular care to detect whether any action prohibited under Rule 28.2.4 of the Technical Rules has occurred. Not only does it mean that the relevant Judge must keep an eye on the vaulter throughout the vault, but they must determine that such action was not merely incidental touching as the athlete cleared the bar. In general, for Rule 28.2.4 of the Technical Rules to be applied there should be some direct action on behalf of the athlete to steady or replace the bar.
- e there is a common practice where athletes return to the box after a trial (whether it is a clearance or failure) and place the pole in the box to check their take-off position. Provided this occurs after the trial is completed in accordance with Rule 25.8 of the

Technical Rules and before the time for the next athlete's trial begins and does not otherwise delay the conduct of the competition, it is allowed.

3. Athletes may, during the competition, place a substance on their hands or on the pole, in order to obtain a better grip. The use of gloves is permitted.

Whilst there is no prohibition on wearing gloves or the use of permitted substances on gloves this practice should be monitored by Referees in case the practice causes concern and gives rise to possible issue of unfair assistance.

4. After the release of the pole, no one including the athlete shall be allowed to touch the pole unless it is falling away from the bar or uprights. If it is touched, however, and the Referee is of the opinion that, but for the intervention, the bar would have been knocked off, the vault shall be recorded as a failure.

This is one of the few rules where behaviour by an official can result in a failure being called. It is important therefore that the upright Judges are diligent in ensuring that they do not touch or catch a pole unless it is clearly falling away from the crossbar and/or uprights.

5. If, in making a trial, an athlete's pole is broken, it shall not be counted as a failure and they shall be awarded a replacement trial.

#### **RUNWAY**

6. The minimum length of the runway, measured from the "zero" line, shall be 40m and where conditions permit, 45m. It shall have a width of  $1.22\text{m} \pm 0.01\text{m}$  and shall be marked by white lines 50mm in width.

*Note: For all tracks constructed before 1 January 2004 the runway may have a width of maximum 1.25m. However, when such a runway is fully resurfaced, the lane width shall comply with this Rule.*

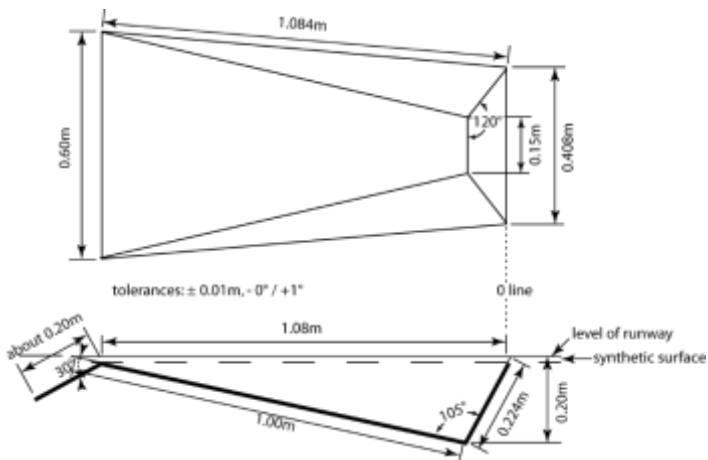
7. The maximum lateral inclination of the runway should be 1:100 (1%) unless special circumstances exist which justify World Athletics providing an exemption and, in the last 40m of the runway,

the overall downward inclination in the direction of running shall not exceed 1:1000 (0.1%).

## APPARATUS

8. The take-off for the Pole Vault shall be from a box. It shall be constructed of suitable material, with rounded or soft upper edges and shall be sunk level with the runway. It shall be 1.00m in length, measured along the inside of the bottom of the box, 0.60m in width at the front end and tapering to 0.15m in width at the bottom of the stop board. The length of the box at runway level and the depth of the stop board are determined by the angle of  $105^\circ$  formed between the base and the stop board. (Tolerances on dimensions and angles:  $\pm 0.01\text{m}$  and  $-0^\circ / +1^\circ$ )

The base of the box shall slope from runway level at the front end to a vertical distance below ground level of 0.20m at the point where it meets the stop board. The box should be constructed in such a manner that the sides slope outwards and end next to the stop board at an angle of approximately  $120^\circ$  to the base.



**Figure (a) Rule 28 TR (Rule 183) - Pole Vault box (top and side view)**



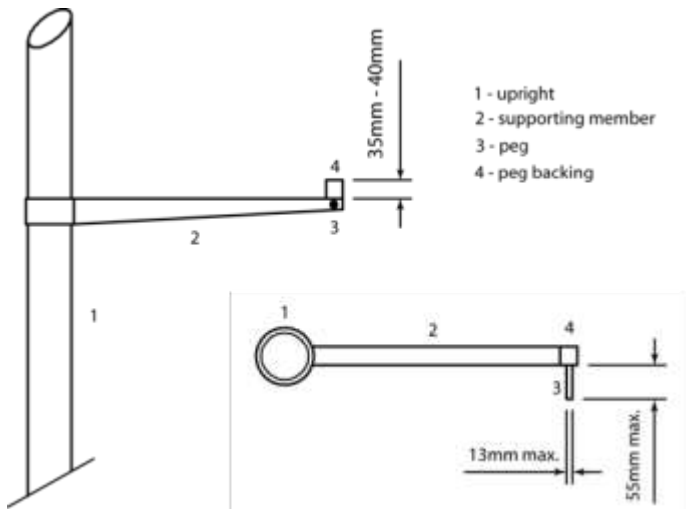
*Note: An athlete may place padding around the box for additional protection during any of their trials. The placement of such equipment shall be done within the time allowed for the athlete's trial and shall be removed by the athlete immediately after their trial is completed. At competitions under paragraphs 1.1, 1.2, 1.3, 1.5 and 1.6 of the International Competition definition this shall be provided by the organisers.*

9. Any style of uprights or posts may be used, provided they are rigid. The metallic structure of the base and the lower part of the uprights above the landing area must be covered with padding of appropriate material in order to provide protection to the athletes and the poles.
10. The crossbar shall rest on horizontal pegs so that if it is touched by an athlete or their pole, it will fall easily to the ground in the direction of the landing area. The pegs shall be without notches or indentations of any kind, of uniform thickness throughout and not more than 13mm in diameter.

They shall not extend more than 55mm from the supporting members, which shall be smooth. The vertical peg backings, which shall also be smooth and be constructed in a way that the crossbar cannot rest on the top of them, shall extend 35mm-40mm above the pegs.

The distance between the pegs shall be 4.28m-4.37m. The pegs shall not be of, or covered with, rubber or with any other material which has the effect of increasing the friction between them and the surface of the bar, nor may they have any kind of springs. The pegs should support the bar in the middle of the end pieces. The crossbar supports shall be at the same height above the surfaces supporting the two upright metal bases.

*Note: To lessen the chance of injury to an athlete by their falling on the feet of the uprights, the pegs supporting the crossbar may be placed upon extension arms permanently attached to the uprights, thus allowing the uprights to be placed wider apart, without increasing the length of the crossbar (see Figure (b) Rule 28 of the Technical Rules).*



**Figure (b) Rule 28 TR (Rule 183) - Pole Vault crossbar support**

(view from landing area and top view)

## VAULTING POLES

11. Athletes may use their own poles. No athlete shall use any other athlete's pole except with the consent of the owner.

The pole may be of any material or combination of materials and of any length or diameter, but the basic surface must be smooth.

The pole may have layers of tape at the grip end (to protect the hand) and of tape and/or any other suitable material at the bottom end (to protect the pole). Any tape at the grip end must be uniform except for incidental overlapping and must not result in any sudden change in diameter, such as the creation of any “ring” on the pole.

Only "regular" taping in accordance with the Rule is allowed at the grip end of the pole - rings, loops and the like are not permitted. There be any restriction on how far up or down the pole such taping extends but it should be for the purpose for which it is intended - to protect the hand.

There is, however, no restriction at the bottom end of the pole and, in general, any form of taping or protection is permitted there - provided it does not give the athlete any advantage.

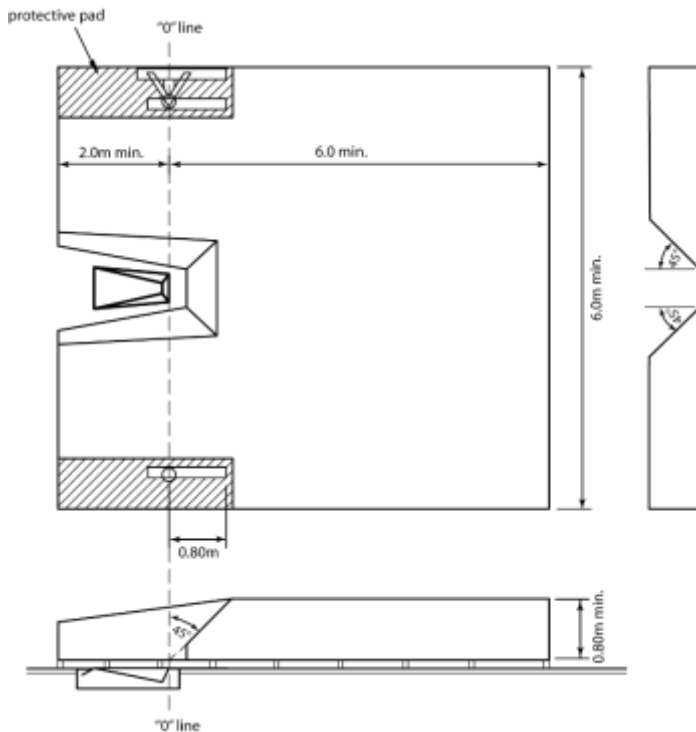
### **LANDING AREA**

12. For competitions under paragraphs 1.1, 1.2, 1.3, 1.5 and 1.6 of the International Competition definition, the landing area shall be not smaller than 6m long (behind the zero line and excluding the front pieces) x 6m wide x 0.8m high. The front pieces must be at least 2m long.

The sides of the landing area nearest to the box shall be placed 0.10m to 0.15m from the box and shall slope away from the box at an angle of approximately 45° (see Figure (c) Rule 28 of the Technical Rules).

For other competitions, the landing area should measure not less than 5m long (excluding the front pieces) x 5m wide x 0.8m high.

*UKA NOTE: The two standards as defined above by World Athletics apply to competition in the UK. Pole Vault beds of the pre 2020 UKA specification are acceptable.*



**Figure (c) Rule 28 TR (Rule 183) - Pole Vault landing area (top and side views)**

### Team of Officials

- a. For a Pole Vault event, it is recommended to allocate the available officials as follows:
  - i. The Chief Judge will watch over the whole of the event and verify the measurements. They must be provided with two flags - white to indicate if the trial is valid and red if it is a failure.

They must place themselves so as to manage two matters in particular:

- ii. Frequently it happens that the cross-bar having been touched by an athlete trembles on the supports. The Chief Judge, depending on the position of the cross-bar, must decide when the vibrating of the bar must be stopped and the appropriate flag raised – particularly the special situations covered in Rules 26.10 and 28.4 of the Technical Rules; and
  - iii. Since before the take-off, the athlete may not touch the ground beyond the vertical plane through the back end of the box they must place themselves in such manner as to be able to determine this.
- b. Two Judges, one on either side, in line with the back of the box, in charge of replacing the crossbar when it falls, and assisting the Chief Judge in applying the above Rules. They are also responsible for the correct placement of the upright as notified by the recorder according to the wishes of the athlete.
  - c. Judge - a recorder noting the upright positions requested by the athletes, scoring the results sheet and calling the upright position and then each athlete (and the one who is to follow).
  - d. Judge in charge of the scoreboard (trial-number-result).
  - e. Judge in charge of the clock indicating to the athletes that they have a certain time to take their trial.
  - f. Judge in charge of athletes.

*Note (i): This is the traditional setting-up of the officials. In major competitions, where a data system and electronic scoreboards are available, specialised personnel are certainly required. To be clear in these cases, the progress and scoring of a Field Event is followed by both the recorder and by the data system.*

*Note (ii): Officials and equipment must be placed in such a way as not to obstruct the athlete's way nor impede the view of the spectators.*

*Note (iii): A space must be reserved for a wind-sock to indicate the wind direction and strength.*

## B. HORIZONTAL JUMPS

### RULE 29 GENERAL CONDITIONS – HORIZONTAL JUMPS

#### RUNWAY

1. The minimum length of the runway, measured from the relevant take-off line shall be 40m and, where conditions permit, 45m. It shall have a width of  $1.22\text{m} \pm 0.01\text{m}$  and shall be marked by white lines 50mm in width.

*Note: For all tracks constructed before 1 January 2004 the runway may have a width of maximum 1.25m. However when such a runway is fully resurfaced, the lane width shall comply with this Rule.*

2. The maximum lateral inclination of the runway should be 1:100 (1%) unless special circumstances exist which justify World Athletics providing an exemption and, in the last 40m of the runway, the overall downward inclination in the direction of running shall not exceed 1:1000 (0.1%).

#### TAKE-OFF BOARD

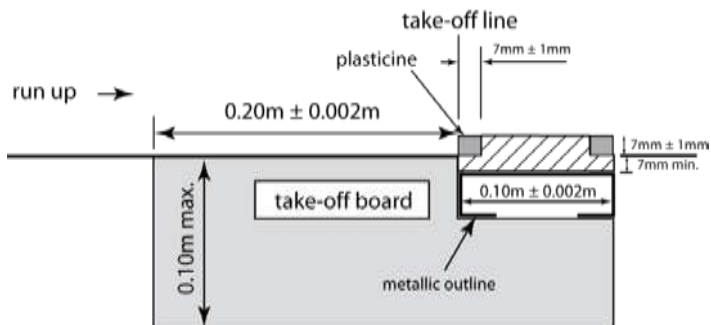
3. The take-off shall be marked by a board sunk level with the runway and the surface of the landing area. The edge of the board which is nearer to the landing area shall be the take-off line. Immediately beyond the take-off line there may be placed a plasticine indicator board for the assistance of the Judges.

*Note: Where in the construction of the runway and/or take-off board there was previously provision for the placement of a plasticine indicator board and such board is not used, this recess should be filled by a blanking board flush with the take-off board.*

4. The take-off board shall be rectangular, made of wood or other suitable rigid material in which the spikes of an athlete's shoe will grip and not skid and shall measure  $1.22\text{m} \pm 0.01\text{m}$  long,  $0.20\text{m} \pm 0.002\text{m}$  wide and not more than 0.10m deep. It shall be white. In order to ensure that the take-off line is clearly distinguishable and in contrast to the take-off board, the ground immediately beyond the take-off line shall be in a colour other than white.
5. The use of video or other technology, to assist the Judges in deciding the application of Rule 30.1 of the Technical Rules, is strongly recommended at all levels of competition. However, if no

technology is available, a plasticine indicator board may still be used.

The plasticine indicator board shall consist of a rigid board,  $0.10\text{m} \pm 0.002\text{m}$  wide and  $1.22\text{m} \pm 0.01\text{m}$  long made of wood or any other suitable material and shall be painted in a contrasting colour to the take-off board. Where possible, the plasticine should be of a third contrasting colour. The board shall be mounted in a recess or shelf in the runway, on the side of the take-off board nearer the landing area. The surface shall rise from the level of the take-off board to a height of  $7\text{mm} \pm 1\text{mm}$ . The edges shall be cut away such that in relation to the recess, when filled with plasticine, the surface of the plasticine nearer to the take-off line shall be at an angle of  $90^\circ$  (see Figure (a) Rule 29 of the Technical Rules).



**Figure (a) Rule 29 TR (Rule 184) - Take-off board and plasticine indicator board**

[From 1 November 2021]

**RULE T29 (184) S 1 UKA SUPPLEMENT - PLASTICINE**

*NOTE: For the avoidance of doubt the plasticine is deemed to be the ground*

When mounted in this recess, the whole assembly shall be sufficiently rigid to accept the full force of the athlete's foot.

The surface of the board beneath the plasticine shall be of a material in which the spikes of an athlete's shoe will grip and not skid.

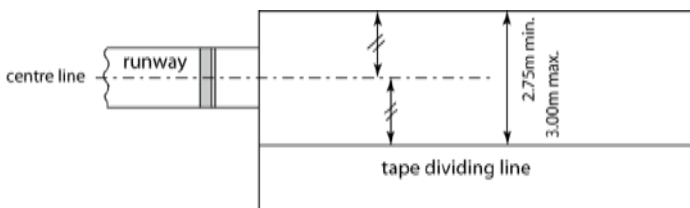
The plasticine can be smoothed off by means of a roller or suitably shaped scraper for the purposes of removing the footprint of an athlete.

[Rules 29.3 to 29.5 amended in June 2019 and in force from 1 November 2021. For current edition of rule please refer to Competition Rule 184.3.]

**LANDING AREA**

6. The landing area shall have a minimum width of 2.75m and a maximum width of 3m. It shall, if possible, be so placed that the middle of the runway, if extended, would coincide with the middle of the landing area.

*Note: When the axis of the runway is not in line with the centre line of the landing area, a tape, or if necessary, two tapes, shall be placed along the landing area so that the above is achieved (see Figure b Rule 29 TR).*



**Figure (b) Rule 29 TR (Rule 184) - Centralised Long Jump /Triple Jump landing area**



Where new facilities are developed at which it is envisaged that visually impaired athletes will compete, at least one pit should be built with an increased width (3.50m instead of maximum 3.00m as in the Rules) as recommended by IPC.

7. The landing area should be filled with soft damp sand, the top surface of which shall be level with the take-off board.

#### **DISTANCE MEASUREMENT**

8. In all horizontal jumping events, distances shall be recorded to the nearest 0.01m below the distance measured if the distance measured is not a whole centimetre.
9. The measurement of each jump shall be made immediately after each valid trial (or after an immediate oral protest made under Rule 8.5 of the Technical Rules) from the nearest break in the landing area made by any part of the body, or anything that was attached to the body at the time it made a mark, to the take-off line, or take-off line extended. The measurement shall be taken perpendicular to the take-off line or its extension.

As long as no irregularity has been committed, each trial must be measured whatever the distance reached, including for the reasons that other trial measurements may become critical in determining countbacks or whether an athlete will proceed to subsequent rounds.

Except where Rule 8.5 of the Technical Rules is applied, under normal practice no trial during which an irregularity has been committed should be measured. Judges should carefully use their discretion in applying any alternate practice and usually only in special cases.

Unless video measuring is being used, for every valid trial a marker (usually metal) should be placed in a vertical position at the place of the imprint left by the athlete in the landing area nearest to the take-off line. The marker is passed through the loop at the end of the graduated metal tape so that the “zero” is on the mark. The tape should be pulled out horizontally taking care not to place it on any rise in the ground.

## WIND MEASUREMENT

10. The wind gauge shall be the same as described in Rules 17.8 and 17.9 of the Technical Rules. It shall be operated as described in Rules 17.11 and 29.12 of the Technical Rules and read as per Rule 17.13 of the Technical Rules.
11. The relevant Field Events Referee shall ensure that the wind gauge is placed 20m from the take-off line. The measuring plane shall be positioned  $1.22\text{m} \pm 0.05\text{m}$  high and not more than 2m away from the runway.
12. The wind velocity shall be measured for a period of 5 seconds from the time an athlete passes a mark placed alongside the runway, for the Long Jump 40m from the take-off line and for the Triple Jump 35m. If an athlete runs less than 40m or 35m, as appropriate, the wind velocity shall be measured from the time they commence their run.

## RULE 30 LONG JUMP

### COMPETITION

1. An athlete fails if:
  - 1.1 they while taking off (prior to the instant at which they cease contact with the take-off board or ground), break the vertical plane of the take-off line with any part of their take-off foot / shoe, whether running up without jumping or in the act of jumping; or  
Rule 30.1.1 amended in June 2019 and in force from 1 November 2021. For the current edition of rule please refer to Competition Rule 185.1.]
  - 1.2 they take off from outside either end of the board, whether beyond or before the extension of the take-off line; or
  - 1.3 they employ any form of somersaulting whilst running up or in the act of jumping; or
  - 1.4 after taking off, but before their first contact with the landing area, they touch the runway or the ground outside the runway or outside the landing area; or
  - 1.5 in the course of landing (including any overbalancing), they touch the border of, or the ground outside, the landing area closer to the take-off line than the nearest break made in the

- 1.6 they leave the landing area in any manner other than that described in Rule 30.2 of the Technical Rules.
- 2 When leaving the landing area, an athlete's first contact by foot with its border or the ground outside shall be further from the take-off line than the nearest break in the sand (which may be any mark made on overbalancing completely inside the landing area or when walking back, closer to the take-off line than the initial break on landing).  
*Note: This first contact is considered leaving.*
- 3 An athlete shall not be regarded to have failed if:
- 3.1 they run outside the white lines marking the runway at any point; or
  - 3.2 except as described in Rule 30.1.2 of the Technical Rules, they take off before reaching the board; or
  - 3.3 under Rule 30.1.2 of the Technical Rules a part of their shoe / foot is touching the ground outside either end of the take-off board, before the take-off line; or
  - 3.4 if in the course of landing, they touch, with any part of their body, or anything attached to it at that moment, the border of, or the ground outside the landing area, unless such contact contravenes Rule 30.1.4 or 30.1.5 of the Technical Rules; or
  - 3.5 they walk back through the landing area after having left the landing area in the manner described in Rule 30.2 of the Technical Rules.

### **TAKE-OFF LINE**

- 4 The distance between the take-off line and the far end of the landing area shall be at least 10m and, where possible, 11m.
- 5 The take-off line shall be placed between 1m and 3m from the nearer end of the landing area.

### **Team of Officials**

For a Long Jump or Triple Jump event, it is recommended to allocate the available officials as follows:

- a. The Chief Judge will watch over the whole of the event.
- b. Judge checking whether the take-off has been made correctly and measuring the trial. They must be provided with two flags

- white to indicate if the trial is valid and red if it is a failure. When the jump has been measured, it is advised that the Judge stands in front of the take-off board, holding the red flag, while the landing area is levelled and, if relevant, the plasticine board is replaced. A cone may be used instead or in addition. (In some competitions this position is assumed by the Chief Judge of the event.)

- c. Judge at the landing point determining the position of the nearest break in the landing area to the take-off line, to insert the spike/prism and then, if a tape is being used, hold the tape on the 0. When video measuring is being used, no judge will normally be required on site for this purpose. When an optic system of measuring is being used on site, two judges are needed at the landing point, one to plant the marker in the sand, the other one to read the result on the optic apparatus.
- d. Judge - a recorder scoring the results sheet and calling each athlete (and the one who is to follow).
- e. Judge in charge of the scoreboard (trial-number-result).
- f. Judge in charge of the wind-gauge positioned at a point 20 metres from the take-off line.
- g. One or more Judges or assistants in charge of levelling the landing area after each trial.
- h. Judge or an assistant in charge of replacing the plasticine.
- i. Judge in charge of the clock indicating to the athletes that they have a certain time to take their trial.
- j. Judge in charge of athletes.

*Note (i): This is the traditional setting-up of the officials. In major competitions, where a data system and electronic scoreboards are available, specialised personnel are certainly required. To be clear in these cases, the progress and scoring of a Field Event is followed by both the recorder and by the data system.*

*Note (ii): Officials and equipment must be placed in such a way as not to obstruct the athlete's way nor impede the view of the spectators.*

*Note (iii): A space must be reserved for a wind-sock to indicate the wind direction and strength.*

## **RULE 31 TRIPLE JUMP**

Rules 29 and 30 of the Technical Rules apply to Triple Jump with the following variations:

### **COMPETITION**

1. The Triple Jump shall consist of a hop, a step and a jump in that order.
2. The hop shall be made so that an athlete lands first on the same foot as that from which they have taken off; in the step they shall land on the other foot, from which, subsequently, the jump is performed. It shall not be considered a failure if an athlete, while jumping, touches the ground with the "sleeping" leg.

*Note: Rule 30.1.4 of the Technical Rules does not apply to the normal landings from the hop and step phases.*

It should be noted that it is not a failure (for that reason alone) if the athlete:

- a. touches the white lines or the ground outside between the take-off line and the landing area; or
- b. lands in the pit in the step phase through no fault of their own (i.e. if the Judge incorrectly indicated the take-off board) - in which such case the Referee would normally offer the athlete a replacement trial.

It is, however a failure if the landing of the jump is not within the landing area.

### **TAKE-OFF LINE**

3. The distance between the take-off line for men and the far end of the landing area shall be at least 21m.
4. For International Competitions, there should be a separate take-off board for men and women. The take-off line shall not be less than 13m for men and 11m for women from the nearer end of the landing area. For any other competition, this distance shall be appropriate for the level of competition.

5. Between the take-off board and the landing area there shall, for the step and jump phases, be a take-off area of  $1.22\text{m} \pm 0.01\text{m}$  wide providing firm and uniform footing.

*Note: For all tracks constructed before 1 January 2004, this take-off area may have a width of maximum 1.25m. However, when such a runway is fully resurfaced, the lane width shall comply with this Rule.*

## C. THROWING EVENTS

### RULE 32 GENERAL CONDITIONS – THROWING EVENTS

#### OFFICIAL IMPLEMENTS

1. In all International Competitions, the implements used shall comply with current World Athletics specifications. Only World Athletics certified implements may be used. The following table shows the implement to be used by each age group:

Implement	Women		Men		Men
	U18	U20/Senior	U18	U20	Senior
Shot	3.000kg	4.000kg	5.000kg	6.000kg	7.260kg
Discus	1.000kg	1.000kg	1.500kg	1.750kg	2.000kg
Hammer	3.000kg	4.000kg	5.000kg	6.000kg	7.260kg
Javelin	500g	600g	700g	800g	800g

*Note: The current standard forms required to be used for the certification and renewal application as well as the Certification System Procedures are available from the World Athletics Office, or may be downloaded from the World Athletics website.*

2. Except as provided below, all such implements shall be provided by the Organisers. The Technical Delegate(s) may, based on the applicable regulations of each competition, allow athletes to use their own personal implements or those provided by a supplier, provided that such implements are World Athletics certified, checked and marked as approved by the Organisers before the competition and made available to all athletes. Such implements will not be accepted if the same model is already on the list of those provided by the Organisers. Unless the Technical Delegate decides otherwise, not more than two implements may be submitted by any athlete for any throwing event in which they are competing.

*Note: “World Athletics certified” implements may include older models that previously held a certificate but are not in production any longer.*

## **RULE T32 (187) S 1 UKA SUPPLEMENT IMPLEMENTS**

Competitors may use any implements provided for general use. Subject to any regulations laid down by the Promoting Body, competitors who wish to use their own implements must submit them to the Referee for approval. An athlete shall not use another's implement without the owner's prior permission.

## **RULE T32 (187) S 2 UKA SUPPLEMENT SAFETY**

In order to avoid accidents the central throwing area or the specific safety sector must be roped off as a unit at a height of approximately 1 metre. Alternatively, shot throwing sectors must be roped off at a height of approximately 1 metre and at a minimum distance of 2 metres outside the shot sector lines.

For safety reasons all throws should be preceded by a warning which shall be acknowledged by the event officials before the throw commences.

*NOTE: Referees are reminded of the need to ensure that discus, hammer and javelin competitions (including warm-up for these events) are not held at the same time within the central throwing area when the standard of any of the competitors is likely to create possible danger to the officials operating within and alongside the respective sectors of these events.*

It is becoming increasingly common for Organisers to provide a lesser range of implements than in the past (largely due to the cost of purchases). This increases the responsibility of Technical Managers and their assistants to closely check all personal implements presented for competitions - to ensure that they comply with the Rules as well as being on the World Athletics list of certified products. Implements which do not currently have but have previously had a World Athletics certificate may be accepted for competition if they comply with the Rules.

3. No modification shall be made to any implements during the competition.

### **ASSISTANCE**

4. The following shall be considered assistance and are therefore not allowed:



- 4.1 The taping of two or more fingers together. If taping is used on the hands and fingers, it may be continuous provided that as a result no two or more fingers are taped together in such a way that the fingers cannot move individually. The taping should be shown to the Chief Judge before the event starts.
- 4.2 The use of any device of any kind, including weights attached to the body, which in any way provides assistance when making a trial.
- 4.3 The use of gloves except in the Hammer Throw. In this case, the gloves shall be smooth on the back and on the front and the tips of the glove fingers, other than the thumb, shall be open.
- 4.4 The spraying or spreading by an athlete of any substance in the circle or on their shoes nor the roughening of the surface of the circle.

*Note: If the Judges are aware, they shall direct any athlete not complying with this rule to correct the situation. If the athlete does not, such trial(s) shall be a failure. If a trial is completed before the non-compliance is noticed, the Referee shall decide what action shall be taken. In all cases considered serious enough, Rule 18.5 of the Competition Rules and Rule 7.2 of the Technical Rules may also be applied.*

5. The following shall not be considered assistance and are therefore allowed:
  - 5.1 The use by an athlete, in order to obtain a better grip, of a suitable substance on their hands only or in the case of a hammer thrower on their gloves. A shot putter may use such substances on their neck.
  - 5.2 The placement by an athlete, in the Shot Put and Discus Throw, on the implement, chalk or a similar substance.

All substances used on the hands, gloves and on the implements shall be easily removable from the implement using a wet cloth and shall not leave any residue. If this is not followed, the note to Rule 32.4 of the Technical Rules shall be applied.

- 5.3 The use of taping on the hands and fingers that is not in contravention of Rule 32.4.1 of the Technical Rules.

### **THROWING CIRCLE**

- 6 The rim of the circle shall be made of band iron, steel or other suitable material, the top of which shall be flush with the ground outside. It shall be at least 6mm thick and shall be white. The ground surrounding the circle may be concrete, synthetic, asphalt, wood or any other suitable material.

The interior of the circle may be constructed of concrete, asphalt or some other firm but not slippery material. The surface of this interior generally shall be level and  $20\text{mm} \pm 6\text{mm}$  lower than the upper edge of the rim of the circle.

In the Shot Put, a portable circle meeting these specifications is permissible.

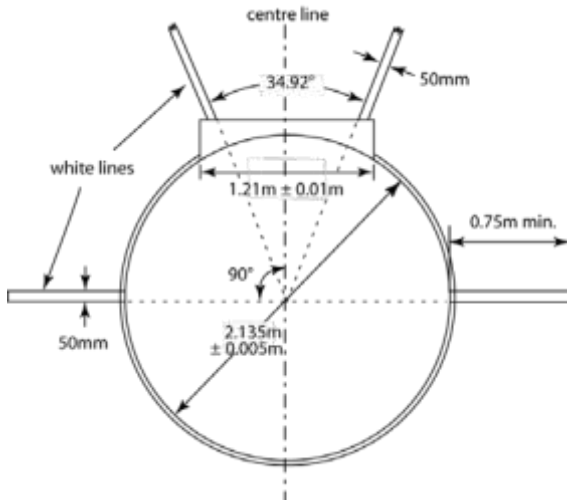
### **RULE T32 (187) S 3 UKA SUPPLEMENT THROWING CIRCLE**

The UKA circle specification shall be used for all new and resurfaced circles. Contact UKA for the latest specification.

7. The inside diameter of the circle shall be  $2.135\text{m} \pm 0.005\text{m}$  in the Shot Put and the Hammer Throw and  $2.50\text{m} \pm 0.005\text{m}$  in the Discus Throw.

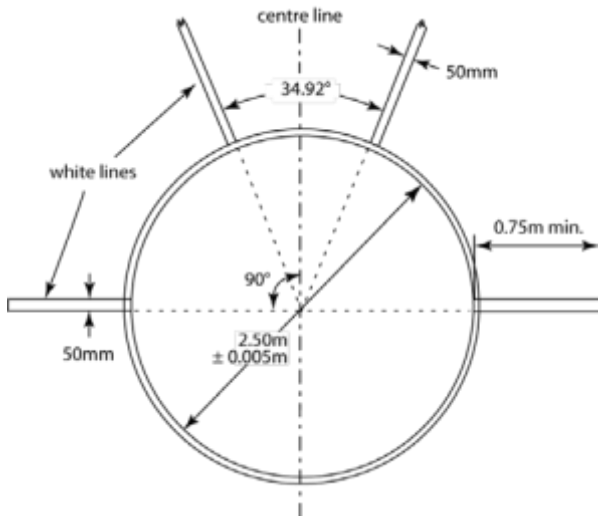
The hammer may be thrown from the discus circle provided the diameter of this circle is reduced from 2.50m to 2.135m by placing a circular ring inside.

*Note: The circular ring should preferably be coloured other than white so that the white lines required by Rule 32.8 of the Technical Rules be clearly visible.*

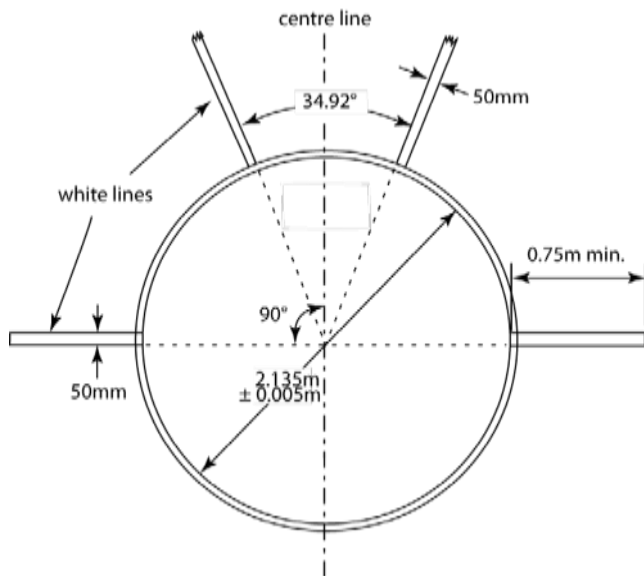


**Figure (a) Rule 32 TR (Rule 187) - Layout of Shot Put circle**

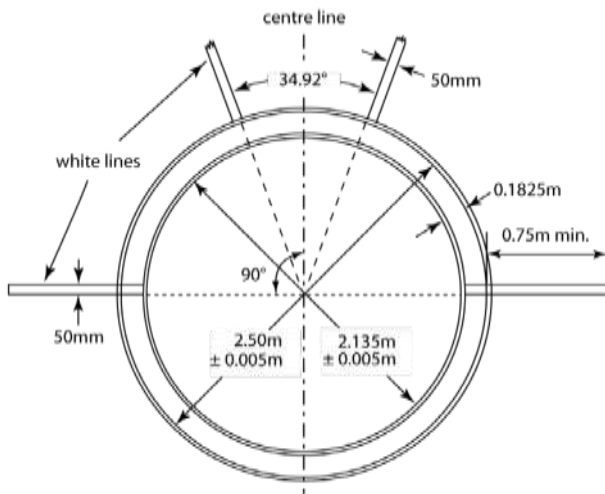
8. A white line 50mm wide shall be drawn from the top of the rim extending for at least 0.75m on either side of the circle. The white line may be painted or made of wood or other suitable material. The rear edge of the white line shall form a prolongation of a theoretical line through the centre of the circle at right angles to the centre line of the landing sector.



**Figure (b) Rule 32 TR (Rule 187) - Layout of Discus Throw circle**



**Figure (c) Rule 32 TR (Rule 187) - Layout of Hammer Throw circle**



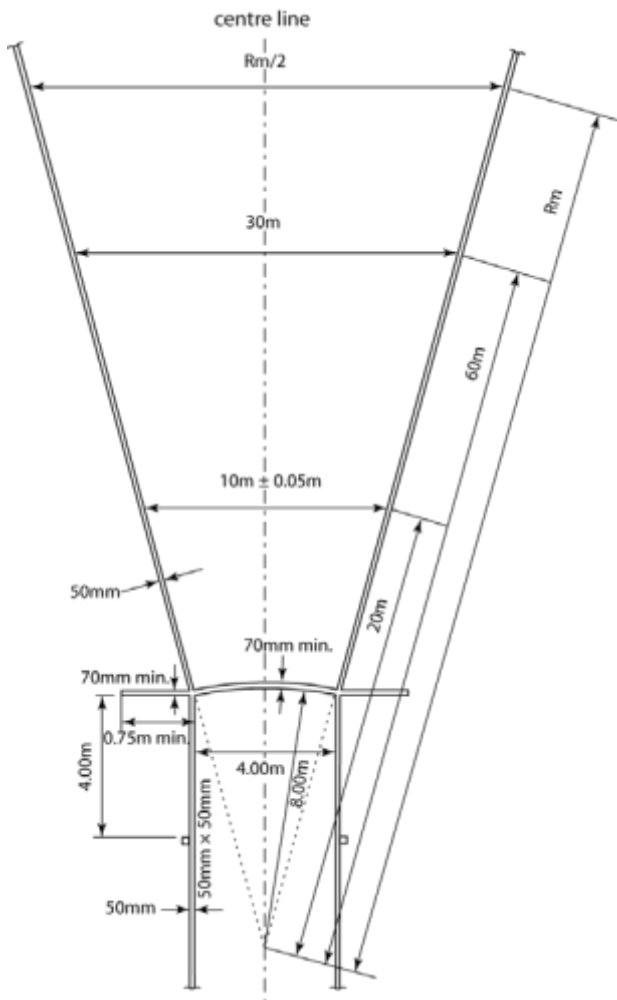
**Figure (d) Rule 32 TR (Rule 187) - Layout of concentric circles for Disc and Hammer Throw circle**

### **JAVELIN THROW RUNWAY**

9. The minimum length of the runway shall be 30m except in competitions held under paragraphs 1.1, 1.2, 1.3, 1.5 and 1.6 of the International Competition definition, where the minimum shall be 33.50m. Where conditions permit, the minimum length should be 36.50m.

It shall be marked by two parallel white lines 50mm wide and 4m apart. The throw shall be made from behind an arc of a circle drawn with a radius of 8m. The arc shall consist of an at least 70mm wide strip painted or made of wood or a suitable non-corrodible material like plastic. It shall be white and be flush with the ground. Lines shall be drawn from the extremities of the arc at right angles to the parallel lines marking the runway. These lines shall be white, at least 0.75m long and at least 70mm wide. The maximum lateral

inclination of the runway should be 1:100 (1%) unless special circumstances exist which justify World Athletics providing an exemption and, in the last 20m of the runway, the overall downward inclination in the direction of running shall not exceed 1:1000 (0.1%).



**Figure (e) Rule 32 TR (Rule 187) - Javelin Throw runway and landing sector (not to scale)**



**LANDING SECTOR**

10. The landing sector shall consist of cinders or grass or other suitable material on which the implement makes an imprint.
11. The maximum overall downward inclination of the landing sector, in the throwing direction, shall not exceed 1:1000 (0.1%).
12. Landing Sector markings:
  - 12.1 Except for the Javelin Throw, the landing sector shall be marked with white lines 50mm wide at an angle of  $34.92^\circ$  such that the inner edge of lines, if extended, would pass through the centre of the circle.
  - 12.2 Note: The  $34.92^\circ$  sector may be laid out accurately by making the distance between the two points on the sector lines 20m from the centre of the circle  $12\text{m} \pm 0.05\text{m}$  ( $20\text{m} \times 0.60\text{m}$ ) apart. Thus, for every 1m from the centre of the circle, the distance across shall be increased by 0.60m.
  - 12.3 In the Javelin Throw, the landing sector shall be marked with white lines 50mm wide such that the inner edge of the lines, if extended, would pass through the two intersections of the inner edges of the arc, and the parallel lines marking the runway and intersect at the centre of the circle of which the arc is part (see Figure (e) Rule 32 of the Technical Rules). The sector angle is thus  $28.96^\circ$ .

The landing sector shall be of an even surface soft enough to ensure that the place of the initial fall of the implement can be clearly established by the Judges. The landing surface should not allow the implement bounce backwards thus creating a risk that the measuring point is obliterated.

**TRIALS**

13. In the Shot Put, Discus Throw and Hammer Throw, implements shall be thrown from a circle, and in the Javelin Throw, from a runway. In the case of trials made from a circle, an athlete shall commence their trial from a stationary position inside the circle. An athlete is allowed to touch the inside of the rim. In the Shot Put, they are also allowed to touch the inside of the stop board described in Rule 33.2 of the Technical Rules.

There is no restriction on how, or from which direction, an athlete may enter the circle. The relevant requirement is that once inside they must adopt a stationary position before commencing their trial.

14. It shall be a failure if an athlete in the course of a trial:
- 14.1 releases the shot or the javelin other than as permitted under Rules 33.1 and 38.1 of the Technical Rules;
  - 14.2 after they have stepped into the circle and begun to make a throw, touches with any part of their body the top (or the top inside edge) of the rim or the ground outside the circle;
- Note: However, it will not be considered a failure if the touch is made without providing any propulsion and occurs during any first rotation at a point completely behind the white line which is drawn outside the circle running, theoretically, through the centre of the circle.*
- 14.3 in the Shot Put, touches with any part of their body any part of the stop board other than its inner side (excluding its top edge which is considered to be part of the top);
  - 14.4 in the Javelin Throw, touches with any part of their body the lines which mark the runway or the ground outside.

*Note: It will not be considered a failure if the discus or any part of the hammer strikes the cage after release, then lands within the landing sector outside the cage, provided that no other Rule is infringed.*

It is clarified that the top inside edges of the rim of the circle and of the stop board are considered to be part of the top of the rim and stop board respectively. This means that should an athlete make contact with the top inside edge of either the rim or the stop-board then they will be considered thereby to have made a failure.

The addition of the Note to Rule 32.14.2 of the Technical Rules applies to rotational techniques used by athletes in Shot Put, Discus Throw or Hammer Throw. It should be interpreted that any “incidental” touch of the top of the rim or the ground outside in respect of the back half of the circle during the first rotation should not, of itself, be regarded as a

failure. However, it is clear that any technique which thereby obtains an advantage through leverage or propulsion would constitute a failure.

15. Provided that, in the course of a trial, the Rules relative to each throwing event have not been infringed, an athlete may interrupt a trial once started, may lay the implement down inside or outside the circle or runway and may leave the circle or runway.

*Note: All the moves permitted by this paragraph shall be included in the maximum time for a trial given in Rule 25.17 of the Technical Rules.*

In these circumstances, there is no restriction on how, or from which direction, an athlete may leave the circle or runway if they choose to do. The relevant requirement is that no other Rule is or has already been infringed.

16. It shall be a failure if the shot, the discus, the hammer head or the head of the javelin in contacting the ground when it first lands touches the sector line or the ground or any object (other than the cage as provided in the Note to Rule 32.14 of the Technical Rules) outside the sector line.

It should be noted that for the purposes of this Rule, the position of the hammer wire or handle is not relevant. For example, the wire could land or be laying on or outside the sector line and it would not matter, provided that the head had landed correctly. The same applies in respect of determining the point from which the measurement is taken under Rule 32.20.1 of the Technical Rules.

17. It shall be a failure if the athlete leaves the circle or runway before the implement has touched the ground, or
  - 17.1 for throws made from a circle, if when leaving the circle, the athlete's first contact with the top of the rim or the ground outside the circle is not completely behind the white line which is drawn outside the circle running, theoretically, through the centre of the circle;

*Note: The first contact with the top of the rim or the ground outside the circle is considered leaving.*

- 17.2 in the case of the Javelin Throw, if, when leaving the runway, the athlete's first contact with the parallel lines or the ground outside the runway is not completely behind the white line of the arc or the lines drawn from the extremities of the arc at right angles to the parallel lines. Once the implement has touched the ground, an athlete will also be considered to have left the runway correctly, upon making contact with or behind a line (painted, or theoretical and indicated by markers beside the runway) drawn across the runway, four metres back from the end points of the throwing arc. Should an athlete be behind that line and inside the runway at the moment the implement touches the ground, they shall be considered to have left the runway correctly.

The second and third sentences in Rule 32.17.2 of the Technical Rules are designed to speed up the judging process and not to create an additional method of calling a failure on the athlete. The purpose of the "4m marks" is solely to enable the Judges to raise the white flag and begin measuring the trial once the athlete retreats behind this point (in the same way as they would do if they had otherwise correctly left the runway). The only requirement is that there is no other reason for calling a failure and that the implement has touched the ground before the white flag is raised. Necessarily, if the athlete for whatever reason never progresses past the "4m marks" when making their throw then the flag can be raised once the implement has landed.

18. After each throw, implements shall be carried back to the area next to the circle or runway and never thrown back.

### **DISTANCE MEASUREMENT**

19. In all throwing events, distances shall be recorded to the nearest 0.01m below the distance measured if the distance measured is not a whole centimetre.
20. The measurement of each throw shall be made immediately after each valid trial (or after an immediate oral protest made under Rule 8.5 of the Technical Rules) from the nearest mark made in contacting the ground when it first lands by:

- 20.1 the shot, discus and hammer head, to the inside of the circumference of the circle along a line to the centre of the circle; or
- 20.2 the head of the javelin to the inside edge of the arc, along a line to the centre of the circle of which the arc is part.

As long as no irregularity has been committed, each trial must be measured whatever the distance reached, including for the reasons that other trial measurements may become critical in determining countbacks or whether an athlete will proceed to subsequent rounds.

Except where Rule 8.5 of the Technical Rules is applied, under normal practice no trial during which an irregularity has been committed should be measured. Judges should carefully use their discretion in applying any alternate practice and usually only in special cases.

Unless video measuring is being used, for every valid trial a marker (usually metal) should be placed in a vertical position at the place of the imprint left by the implement in the landing area nearest to the arc. The marker is passed through the loop at the end of the graduated metal tape so that the “zero” is on the mark. The tape should be pulled out horizontally taking care not to place it on any rise in the ground.

## **RULE 33 SHOT PUT**

### **COMPETITION**

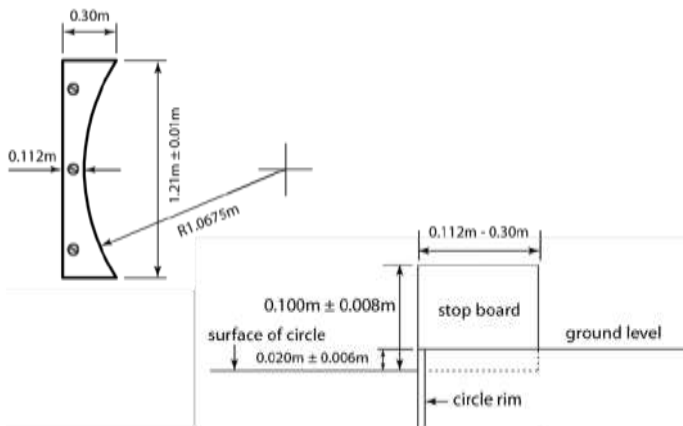
1. The shot shall be put from the shoulder with one hand only. At the time an athlete takes a stance in the circle to commence a put, the shot shall touch or be in close proximity to the neck or the chin and the hand shall not be dropped below this position during the action of putting. The shot shall not be taken behind the line of the shoulders.

*Note: Cartwheeling techniques are not permitted.*

### **STOP BOARD**

2. The stop board shall be white and made of wood or other suitable material in the shape of an arc so that the inner surface aligns with the inner edge of the rim of the circle and is perpendicular to the surface of the circle. It shall be placed so that its centre coincides with the centre line of the landing sector (see Figure Rule 33 of the

Technical Rules), and shall be firmly fixed to the ground or to the concrete surrounding the circle.



**Figure Rule 33 TR (Rule 188) - Shot Put stop board (top and side view)**

*Note: Stop boards to the 1983/84 World Athletics specifications remain acceptable.*

- The stop board shall measure 0.112m to 0.30m wide, with a chord of  $1.21\text{m} \pm 0.01\text{m}$  for an arc of the same radius as the circle and  $0.10\text{m} \pm 0.008\text{m}$  high in relation to the level of the inside of the circle adjacent to the stop board.

## SHOT

- The shot shall be of solid iron, brass or any metal not softer than brass, or a shell of such metal filled with lead or other solid material. It shall be spherical in shape and its surface finish shall be smooth. Information for manufacturers: to be smooth, the surface average height must be less than  $1.6\mu\text{m}$ , i.e. a roughness number N7 or less.
- The shot shall conform to the following specifications:

Minimum weight for admission to competition and acceptance of a Record:

	3.000kg	4.000kg	5.000kg	6.000kg	7.260kg
Diameter:					
Minimum	85mm	95mm	100mm	105mm	110mm
Maximum	110mm	110mm	120mm	125mm	130mm

### Team of Officials

For a Shot Put event, it is recommended to allocate the available officials as follows:

- a. The Chief Judge will watch over the whole of the event.
- b. Two Judges checking whether the put has been made correctly and measuring the trial. One must be provided with two flags - white to indicate if the trial is valid and red if it is a failure. When the put has been measured, it is advised that the Judge stands in the circle holding the red flag, while the implement is returned and the landing area is cleared. A cone may be placed in the circle instead. (In some competitions this position is assumed by the Chief Judge of the event.) Where EDM is not in use, the second Judge should pull through and hold the measuring tape in such a way that it passes through the centre of the circle.
- c. Judge immediately after the throw placing a marker indicating the point from which the trial is to be measured.
- d. Judge positioning the spike/prism at the point where the marker has been placed ensuring the tape is on the zero mark.
- e. Judge in charge of retrieving the implements and returning them to the implement stand or placing them in the return chute.
- f. Judge - a recorder scoring the results sheet and calling each athlete (and the one who is to follow).
- g. Judge in charge of the scoreboard (trial-number-result).
- h. Judge in charge of the clock indicating to the athletes that they have a certain time to take their trial.
- i. Judge in charge of athletes.
- j. Judge in charge of the implement stand.

*Note (i): This is the traditional setting-up of the officials. In major competitions, where a data system and electronic scoreboards are available, specialised personnel are certainly required. To be clear in these cases, the progress and scoring of a Field Event is followed by both the recorder and by the data system.*

*Note (ii): Officials and equipment must be placed in such a way as not to obstruct the athlete's way nor impede the view of the spectators.*

**RULE T33 (188) S 1 UKA SUPPLEMENT  
SHOT SPECIFICATIONS FOR NON- WORLD ATHLETICS  
AGE GROUPS**

	<b>Min</b>	<b>Max</b>	<b>Min</b>	<b>Max</b>
<b>MEN</b>	<b>UNDER 17</b>		<b>UNDER 15</b>	
Weight	5kg	-	4kg	-
Diameter	100mm	120mm	95mm	110mm
	<b>UNDER 13</b>			
Weight	3kg	-		
Diameter	85mm	110mm		
<b>WOMEN</b>	<b>UNDER 17 UNDER 15</b>		<b>UNDER 13</b>	
Weight	3kg	-	2.72kg	-
Diameter	85mm	110mm	85mm	110mm
<b>MASTERS</b>	<b>MEN 35-49</b>		<b>MEN 50-59</b>	
Weight	7.26kg	-	6kg	-
Diameter	110mm	130mm	105mm	130mm
	<b>MEN 60-69</b>		<b>MEN 70-79</b>	
Weight	5kg	-	4kg	-
Diameter	100mm	130mm	95mm	130mm
	<b>MEN 80 and over</b>			
Weight	3kg	-		
Diameter	85mm	130mm		



	WOMEN 35–49		WOMEN 50–74	
Weight	4kg	–	3kg	–
Diameter	95mm	130mm	85mm	130mm
	WOMEN 75 +			
Weight	2kg	–		
Diameter	80mm	110mm		

### RULE 34 DISCUS THROW

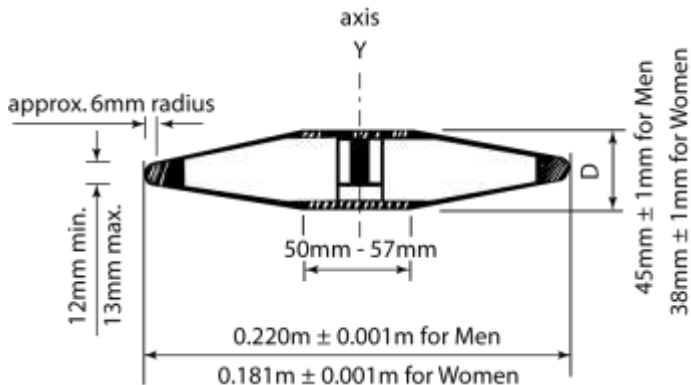
#### DISCUS

- The body of the discus may be solid or hollow and shall be made of wood, or other suitable material, with a metal rim, the edge of which shall be circular. The cross section of the edge shall be rounded in a true circle having a radius of approximately 6mm. There may be circular plates set flush into the centre of the sides. Alternatively, the discus may be made without metal plates, provided that the equivalent area is flat and the measurements and total weight of the implement correspond to the specifications.

Each side of the discus shall be identical and shall be made without indentations, projections or sharp edges. The sides shall taper in a straight line from the beginning of the curve of the rim to a circle of a radius of 25mm to 28.5mm from the centre of the discus.

The profile of the discus shall be designed as follows. From the beginning of the curve of the rim the thickness of the discus increases regularly up to the maximum thickness D. This maximum value is achieved at a distance of 25 mm to 28.5mm from the axis of the discus Y. From this point up to the axis Y the thickness of the discus is constant. Upper and lower side of the discus must be identical; also the discus has to be symmetrical concerning rotation around the axis Y.

The discus, including the surface of the rim shall have no roughness and the finish shall be smooth (see Rule 33.4 of the Technical Rules) and uniform throughout.



**Figure Rule 34 TR (Rule189) – Discus**

2. The discus shall conform to the following specifications:  
Minimum weight for admission to competition and acceptance of a Record

	1.000kg	1.500kg	1.750kg	2.000kg
Outside diameter of metal rim:				
Minimum	180mm	200mm	210mm	219mm
Maximum	182mm	202mm	212mm	221mm
Diameter of metal plate or flat centre area:				
Minimum	50mm	50mm	50mm	50mm
Maximum	57mm	57mm	57mm	57mm
Thickness of metal plate or flat centre area:				
Minimum	37mm	38mm	41mm	44mm
Maximum	39mm	40mm	43mm	46mm
Thickness of metal rim (6mm from edge):				
Minimum	12mm	12mm	12mm	12mm
Maximum	13mm	13mm	13mm	13mm

**RULE T34 (189) S 1 UKA SUPPLEMENT  
DISCUS SPECIFICATIONS FOR  
NON- WORLD ATHLETICS AGE GROUPS**

	Weight	Outer Dia of Metal Rim		Dia of Metal Plates		Thickness at Centre		Thickness of Rim at 6mm from the Edge	
		Min mm	Min mm	Min mm	Min mm	Min mm	Min mm	Min mm	Min mm
<b>Men</b>	KG								
<b>U17</b>	1.5	200	202	50	57	38	40	12	13
<b>U15</b>	1.25	180	182	50	57	37	39	12	13
<b>U13</b>	1.0	180	182	50	57	37	39	12	13
<b>Women</b>									
<b>U17 &amp; U15</b>	1.0	180	182	50	57	37	39	12	13
<b>U13</b>	0.75	145	170	50	57	25	35	10	11
<b>Masters</b>									
<b>Men 35-49</b>	2.0	219	221	50	57	44	46	12	13
<b>Men 50-59</b>	1.5	200	202	50	57	38	40	12	13
<b>Men 60+</b>	1.0	180	182	50	57	37	39	12	13
<b>Women 35-74</b>	1.0	180	182	50	57	37	39	12	13
<b>Women 75+</b>	0.75	145	170	50	57	25	35	10	11

**Team of Officials**

For a Discus Throw event, it is recommended to allocate the available officials as follows:

- a. The Chief Judge will watch over the whole of the event.
- b. Two Judges checking whether the throw has been made correctly and measuring the trial. One must be provided with two flags - white to indicate if the trial is valid and red if it is a failure. When the throw has been measured, it is advised that the Judge stands at the entrance to the cage holding the red flag, while the implement is returned, and the landing area is cleared. A cone may be placed at this point instead. (In some

competitions this position is assumed by the Chief Judge of the event.)

Where EDM is not in use the second Judge should pull through and hold the measuring tape in such a way that it passes through the centre of the circle.

- c. Judge immediately after the throw placing a marker indicating the point from which the trial is to be measured. If the implement lands outside the sector either this Judge or the one with the spike/prism (whichever is closer to the line) should indicate this by holding their arm outstretched. No indication is required for a valid trial.
- d. Judge positioning the spike/prism at the point where the marker has been placed ensuring the tape is on the zero mark.
- e. one or more Judges or assistants in charge of retrieving the implements and returning them to the implement stand or placing them in the return device. Where a tape is used for measurement, one of these Judges or assistants should ensure that the tape measure is taut in order to ensure a correct measurement.
- f. Judge - a recorder scoring the results sheet and calling each athlete (and the one who is to follow).
- g. Judge in charge of the scoreboard (trial-number-result).
- h. Judge in charge of the clock indicating to the athletes that they have a certain time to take their trial.
- i. Judge in charge of athletes.
- j. Judge in charge of the implement stand.

*Note (i): This is the traditional setting-up of the officials. In major competitions, where a data system and electronic scoreboards are available, specialised personnel are certainly required. To be clear in these cases, the progress and scoring of a Field Event is followed by both the recorder and by the data system.*

*Note (ii): Officials and equipment must be placed in such a way as not to obstruct the athlete's way nor impede the view of the spectators.*

*Note (iii): A space must be reserved for a wind-sock to indicate the wind direction and strength.*

### **RULE 35 DISCUS CAGE**

1. All discus throws shall be made from an enclosure or cage to ensure the safety of spectators, officials and athletes. The cage specified in this Rule is intended for use when the event takes place in the Field of Play with other events taking place at the same time or when the event takes place outside the Field of Play with spectators present. Where this does not apply, and especially in training areas, a much simpler construction may be satisfactory. Advice is available, on request, from Members or from the World Athletics Office.

*Note (i): The hammer cage specified in Rule 37 of the Technical Rules may also be used for Discus Throw, either by installing 2.135/2.50m concentric circles, or by using the extension of the gates of that cage with a separate discus circle installed in front of the hammer circle.*

*Note (ii): The hammer cage movable panels may be used when the cage is being used for discus throw to limit the danger zones.*

2. The cage should be designed, manufactured and maintained so as to be capable of stopping a 2kg discus moving at a speed of up to 25 metres per second. The arrangement should be such that there is no danger of ricocheting or rebounding back towards the athlete or over the top of the cage. Provided that it satisfies all the requirements of this Rule, any form of cage design and construction can be used.
3. The cage should be U-shaped in plan as shown in Figure Rule 35 of the Technical Rules. The width of the mouth should be 6m, positioned 7m in front of the centre of the throwing circle. The end points of the 6m wide mouth shall be the inner edge of the cage netting. The height of the netting panels or draped netting at their lowest point should be at least 4m and it should be at least 6m for the 3m nearest the front of the cage on each side [from 1 January 2020].

Provision should be made in the design and construction of the cage to prevent a discus forcing its way through any joints in the cage or the netting or underneath the netting panels or draped netting.

*Note (i): The arrangement of the rear panels/netting is not important provided the netting is a minimum of 3.00m away from the centre of the circle.*

*Note (ii): Innovative designs that provide the same or better degree of protection and do not increase the danger zone compared with conventional designs may be World Athletics certified.*

*Note (iii): The cage side, particularly alongside the track, may be lengthened and/or provided with (a) movable panel(s) and/or increased in height so as to provide greater protection to athletes competing on the adjoining track during a discus competition.*

The netting must be fixed in a way that the width of the mouth is the same at each height of the netting. This applies also for the panels when put into a position according to Rule 37.4 of the Technical Rules Note (ii).

4. The netting for the cage can be made from suitable natural or synthetic fibre cord or, alternatively, from mild or high tensile steel wire. The maximum mesh size shall be 45mm for cord netting and 50mm for steel wire.

*Note: Further specifications for the netting and safety inspection procedures are set out in the World Athletics Track and Field Facilities Manual.*

5. The maximum danger sector for discus throws from this cage is approximately 69°, when used by both right and left handed throwers in the same competition (calculated by assuming that the discus is released from a circumscribed circle of 1.5m radius). The position and alignment of the cage in the Field of Play is, therefore, critical for its safe use.

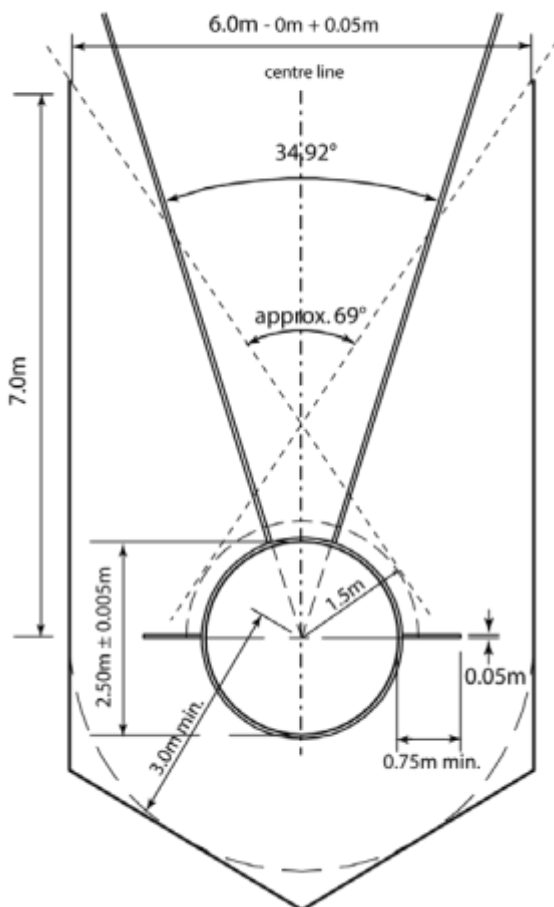
*Note: The method used to determine the danger zone is illustrated in Figure Rule 35 of the Technical Rules.*

### **RULE T35 (190) S1 UKA SUPPLEMENT DISCUS CAGE**

1. All Pre-November 2018 UKA specification discus only cages must be modified/replaced to meet the 2020 WORLD ATHLETICS cage specification - see Figure Rule 35 TR (Rule 190), resulting in

a discus danger zone of no more than 69° (i.e. in compliance with Rule 35.5).

2. All cage modifications/installations must be carried out by an approved member of SAPCA's Track & Field division.
3. Post January 2020 all new/replacement discus only cage installations must hold a valid WORLD ATHLETICS product certificate (i.e. have an WORLD ATHLETICS certification number that is valid at the time of installation).
4. The discus cage netting should meet EN 1263-1:1996.



**Figure Rule 35 TR (Rule 190) - Cage for Discus Throw only (with cage dimensions to netting)**



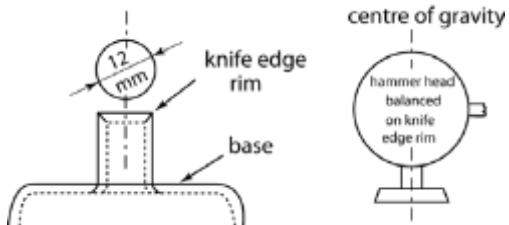
## **RULE 36 HAMMER THROW**

### **COMPETITION**

1. An athlete, in their starting position prior to the preliminary swings or turns, is allowed to put the head of the hammer on the ground inside or outside the circle.
2. It shall not be considered a failure if the head of the hammer touches the ground inside or outside the circle, or the top of the rim. The athlete may stop and begin the throw again, provided no other Rule has been breached.
3. If the hammer breaks during a throw or while in the air, it shall not count as a failure, provided the trial was otherwise made in accordance with this Rule. Nor shall it count as a failure if an athlete thereby loses their balance and as a result contravenes any part of this Rule. In both cases the athlete shall be awarded a replacement trial.

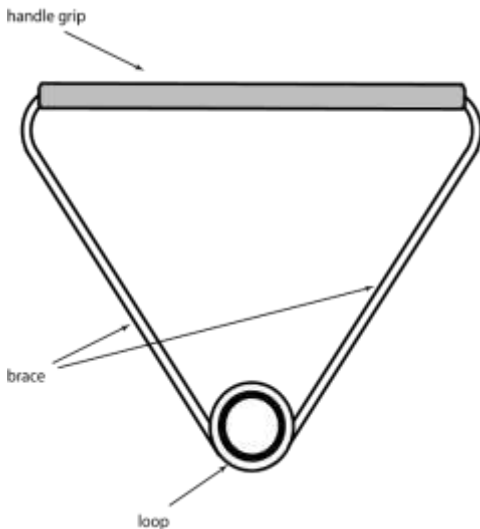
### **HAMMER**

4. The hammer shall consist of three main parts: a metal head, a wire and a handle.
5. The head shall be of solid iron, brass or other metal not softer than brass or a shell of such metal filled with lead or other solid material. The centre of gravity of the head shall be not more than 6mm from the centre of the sphere, i.e. - it must be possible to balance the head, less handle and wire, on a horizontal sharp-edged circular orifice 12mm in diameter (see Figure (a) Rule 36 of the Technical Rules). If a filling is used, this shall be inserted in such manner that it is immovable and complies with the requirement for the centre of gravity.



**Figure (a) Rule 36 TR (Rule 191) - Suggested apparatus for testing centre of gravity of hammer head**

6. The wire shall be a single unbroken and straight length of spring steel wire not less than 3mm in diameter and shall be such that it cannot stretch appreciably while the hammer is being thrown. The wire may be looped at one or both ends as a means of attachment. The wire shall be connected to the head by means of a swivel, which may be either plain or ball bearing.
7. The handle shall be rigid and without hinging joints of any kind. The total deformation of the handle under a tension load of 3.8kN shall not exceed 3mm. It shall be attached to the wire in such a manner that it cannot be turned within the loop of the wire to increase the overall length of the hammer. The handle shall be connected to the wire by means of a loop. A swivel may not be used. The handle shall have a symmetric design and may have a curved or straight grip and/or brace. The minimum handle breaking strength shall be 8kN.



**Figure (b) Rule 36 TR (Rule 191) - Generic hammer handle**

Note: Other designs complying with the specifications are acceptable.

8. The hammer shall conform to the following specifications:  
 Minimum weight for admission to competition and acceptance of a Record:

	3.000kg	4.000kg	5.000kg	6.000kg	7.260kg
Length of hammer measured from inside of handle:					
Maximum	1195mm	1195mm	1200mm	1215mm	1215mm
Diameter of head:					
Minimum	85mm	95mm	100mm	105mm	110mm
Maximum	100mm	110mm	120mm	125mm	130mm

*Note: The weight of the implement includes the totality of the hammer head, wire and handle.*

### Team of Officials

For a Hammer Throw event, it is recommended to allocate the available officials as follows:

- a. The Chief Judge will watch over the whole of the event.
- b. Two Judges checking whether the throw has been made correctly and measuring the trial. One must be provided with two flags - white to indicate if the trial is valid and red if it is a failure. When the throw has been measured, it is advised that the Judge stands at the entrance to the cage holding the red flag, while the implement is returned and the landing area is cleared. A cone may be placed at this point instead. (In some competitions this position is assumed by the Chief Judge of the event.)

Where EDM is not in use the second Judge should pull through and hold the measuring tape in such a way that it passes through the centre of the circle.

- c. Judge immediately after the throw placing a marker indicating the point from which the trial is to be measured. If the implement lands outside the sector either this Judge or the one with the spike/prism (whichever is closer to the line) should indicate this by holding their arm outstretched. No indication is required for a valid trial.
- d. Judge positioning the spike/prism at the point where the marker has been placed ensuring the tape is on the zero mark.
- e. one or more Judges or assistants in charge of retrieving the implements and returning them to the implement stand or placing them in the return device. Where a tape is used for measurement, one of these Judges or assistants should ensure that the tape measure is taut in order to ensure a correct measurement.
- f. Judge - a recorder scoring the results sheet and calling each athlete (and the one who is to follow).
- g. Judge in charge of the scoreboard (trial-number-result).
- h. Judge in charge of the clock indicating to the athletes that they have a certain time to take their trial.

- i. Judge in charge of athletes.
- j. Judge in charge of the implement stand.

*Note (i): This is the traditional setting-up of the officials. In major competitions, where a data system and electronic scoreboards are available, specialised personnel are certainly required. To be clear in these cases, the progress and scoring of a Field Event is followed by both the recorder and by the data system.*

*Note (ii): Officials and equipment must be placed in such a way as not to obstruct the athlete's way nor impede the view of the spectators.*

**RULE T36 (191) S 1 UKA SUPPLEMENT  
HAMMER SPECIFICATIONS FOR NON- WORLD  
ATHLETICS AGE GROUPS**

	Min	Max	Min	Max		
<b>MEN</b>	<b>UNDER 17</b>		<b>UNDER 15</b>			
Weight Complete	5kg	-	4kg	-		
Length of Hammer	-	1200mm	-	1195mm		
Diameter of Head	100mm	120mm	95mm	110mm		
	<b>UNDER 13</b>					
Weight Complete	3kg	-				
Length of Hammer	-	1195mm				
Diameter of Head	85mm	100mm				
<b>WOMEN</b>	<b>UNDER 17 UNDER 15 UNDER 13</b>					
Weight Complete	3kg	-				
Length of Hammer	-	1195mm				
Diameter of Head	85mm	100mm				
<b>MASTERS</b>	<b>MEN 35-49</b>				<b>MEN 50-59</b>	
Weight Complete	7.26kg	-			6kg	-
Length of Hammer	-	1215mm	-	1215mm		

WORLD ATHLETICS AND UKA TECHNICAL RULES 2020 EDITION

Diameter of Head	110mm 130mm	130mm 125mm	105mm	125mm 130mm
	<b>MEN 60–69</b>		<b>MEN 70–79</b>	
Weight Complete	5kg	–	4kg	–
Length of Hammer	–	1200mm	–	1195mm
Diameter of Head	100mm	120mm	95mm	110mm
	<b>MEN 80 and over</b>			
Weight Complete	3kg	–		
Length of Hammer	–	1195mm		
Diameter of Head	85mm	100mm		
	<b>WOMEN 35–49</b>		<b>WOMEN 50–74</b>	
Weight Complete	4kg	–	3kg	–
Length of Hammer	–	1195mm	–	1195mm
Diameter of Head	95mm	110mm	85mm	100mm
	<b>WOMEN 75 and over</b>			
Weight Complete	2kg	–		
Length of Hammer	–	1195mm		
Diameter of Head	80mm	90mm		

**RULE 37 HAMMER CAGE**

1. All hammer throws shall be made from an enclosure or cage to ensure the safety of spectators, officials and athletes. The cage specified in this Rule is intended for use when the event takes place in the Field of Play with other events taking place at the same time or when the event takes place outside the Field of Play with spectators present. Where this does not apply, and especially in training areas, a much simpler construction may be satisfactory. Advice is available on request from Members or from the World Athletics Office.
2. The cage should be designed, manufactured and maintained so as to be capable of stopping a 7.260kg hammer head moving at a speed of up to 32 metres per second. The arrangement should be such that there is no danger of ricocheting or rebounding back towards the athlete or over the top of the cage. Provided that it satisfies all the requirements of this Rule, any form of cage design and construction can be used.
3. The cage should be U-shaped in plan as shown in Figure (a) Rule 37 of the Technical Rules. The width of the mouth should be 6m, positioned 7m in front of the centre of the throwing circle. The end points of the 6m wide mouth shall be the inner edge of the pivoted netting. The height of the netting panels or draped netting at their lowest point shall be at least 7m for the panels/netting at the rear of the cage and at least 10m for the last 2.80m panels to the gate netting pivot points.

Provisions should be made in the design and construction of the cage to prevent a hammer forcing its way through any joints in the cage or the netting or underneath the netting panels or draped netting.

*Note: The arrangement of the rear panels / netting is not important provided the netting is a minimum of 3.50m away from the centre of the circle.*

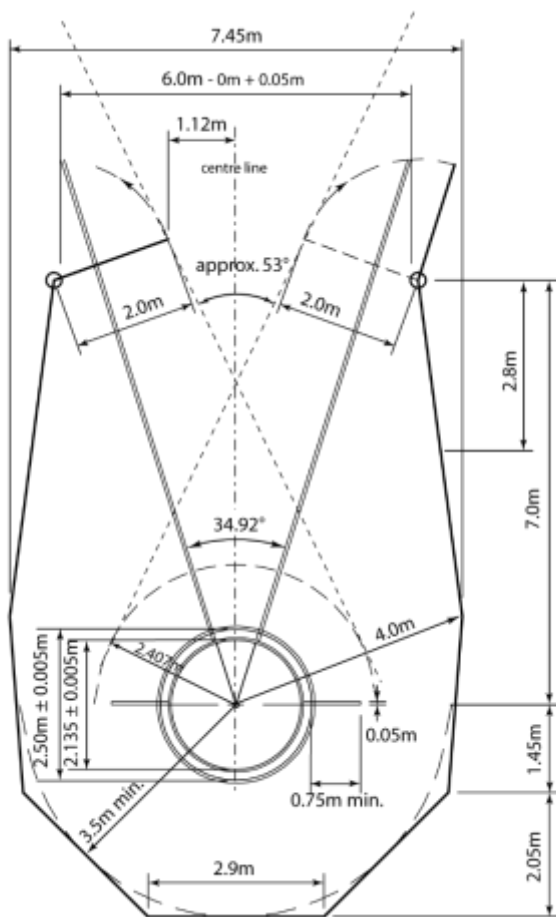
**RULE T37 (192) S 1 UKA SUPPLEMENT  
HAMMER CAGE**

1. All pre-November 2018 UKA specification *two-circle* cages (i.e. with separate, dedicated hammer & discus circles) must be modified to give at least the same degree of safety as the recommended WORLD ATHLETICS design i.e. achieve a maximum danger zone angle of  $56^{\circ}$  for hammer throw and  $69^{\circ}$  for discus throw. Such modifications will have been achieved either by:
  - a. Discarding/filling the front hammer circle and converting the rear discus circle to a combined hammer/discus circle using a concentric insert, thereby reducing the hammer throw danger zone angle to an acceptable level (maximum  $56^{\circ}$ ) - see Figure (d) Rule 37 TR (Rule 192) S1, or
  - b. Retaining the hammer and discus circles but increasing the gate width to circa 3.0m wide and amending the hammer gate closed position to a point nearer to the centreline to deliver a reduced hammer throw danger zone angle of no more than  $53^{\circ}$  - see Figure (e) Rule 37 TR (Rule 192) S1.
2. All pre-November 2018 UKA specification *single circle* cages (hammer only or combined hammer & discus), must be modified to give at least the same degree of safety as the recommended WORLD ATHLETICS design i.e. achieve a maximum danger zone angle of  $53^{\circ}$  for hammer throw and  $69^{\circ}$  for discus throw (as described in Rule 37.7 and Rule 35.5 respectively). Such modifications will have been achieved either by:
  - a. Increasing the gate width size to circa 3.0m and moving the hammer gate fixing positions nearer to the centreline to deliver a reduced danger zone angle of no more than  $53^{\circ}$ . Additionally, two new fixing points set parallel to the throws sector centreline will need to be drilled to achieve a revised discus danger zone of no more than  $69^{\circ}$  – see Figure (f) Rule 37 TR (Rule 192) S1, or by
  - b. Removing the existing 9.00m cage gates, adding 2x new 2.80m side panels and 2 x new 10.0m cage gates (gate

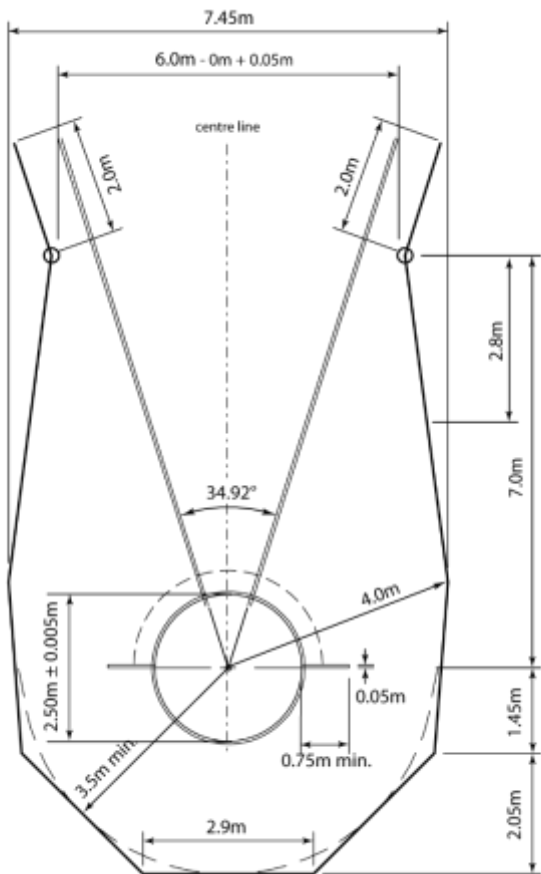


width = 2.0m), replacing existing netting with new netting and drilling 2 x new gate fixing points to deliver a reduced hammer throw danger zone angle of no more than 53° - see Figure (a) Rule 37 TR (Rule 192) and Figure (b) Rule 37 TR (Rule 192).

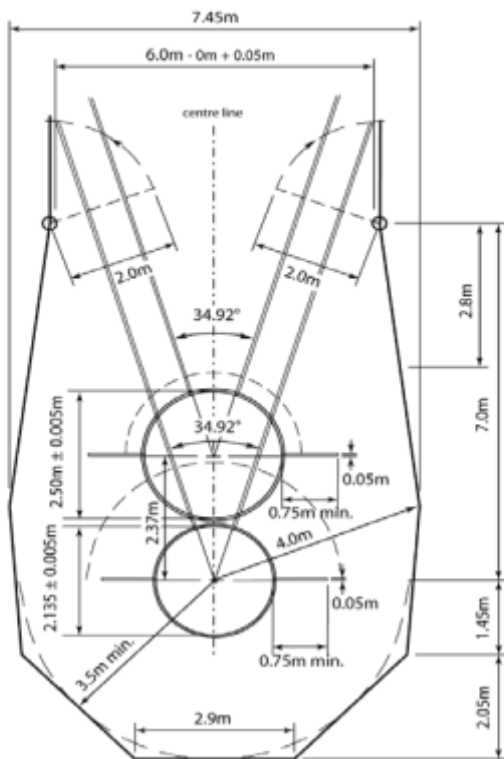
3. All cage modifications/installations must be carried out by an approved member of SAPCA's Track & Field division.
4. All new/replacement Hammer/Combined Hammer & Discus cage installations must be WORLD ATHLETICS certified (i.e. have an WORLD ATHLETICS certification number that is valid at the time of installation).
5. For pre-November 2018 cages that have been modified in accordance with Rule 37.1 S 1 and Rule 37.2(a) S 1 as above:
  - a. The cage should be U-shaped in plan and the width of the mouth should be 6m. The end points of the 6m wide mouth shall be the inner edge of the cage netting.
  - b. There is a minimum 3.00m radius from the centre of the circle to the rear netting (ideally 3.50m).
6. The Hammer/Combined Hammer & Discus cage netting should meet EN 1263-1:1996.



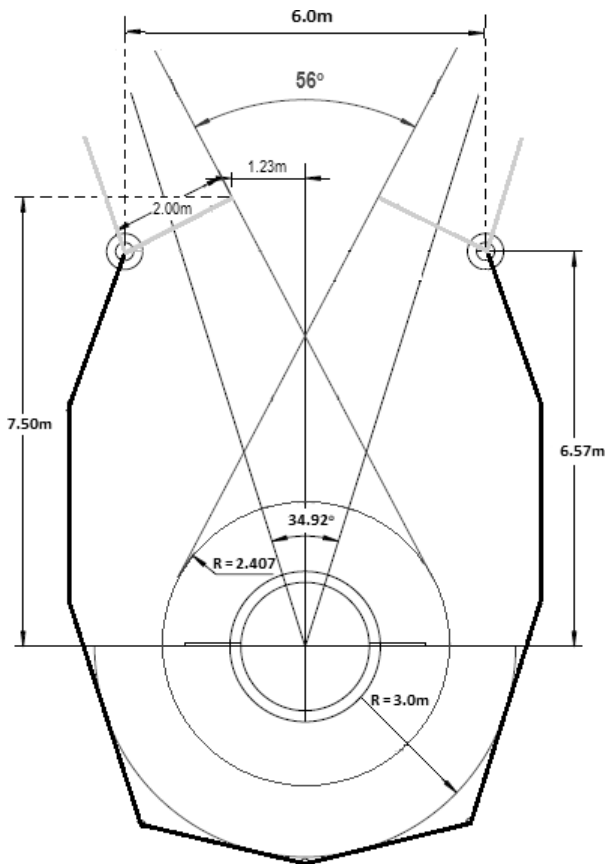
**Figure (a) Rule 37 TR (Rule 192) - Cage for Hammer and Discus Throw with concentric circles**  
 (Hammer Throw configuration, with cage dimensions to netting)



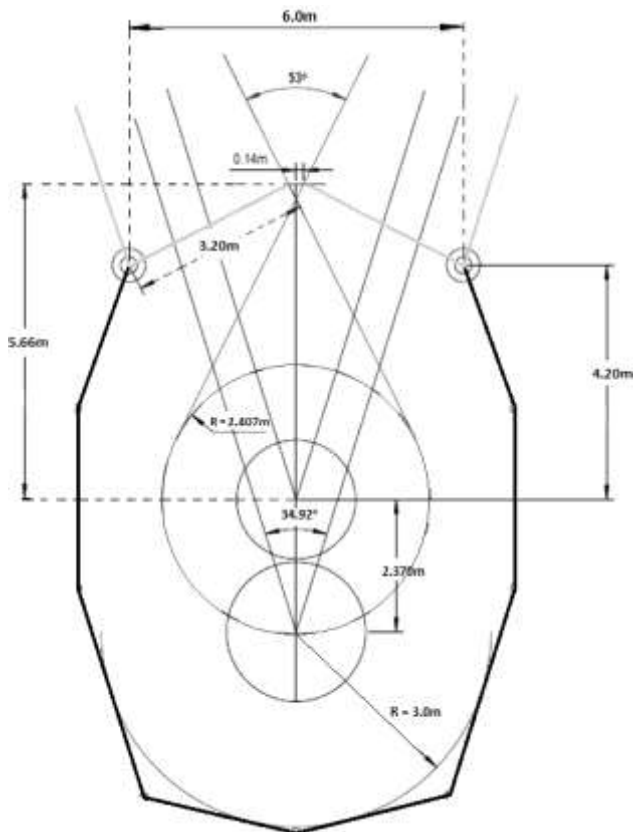
**Figure (b) Rule 37 TR (Rule 192) - Cage for Hammer and Discus Throw with concentric circles**  
 (Discus Throw configuration, with cage dimensions to netting)



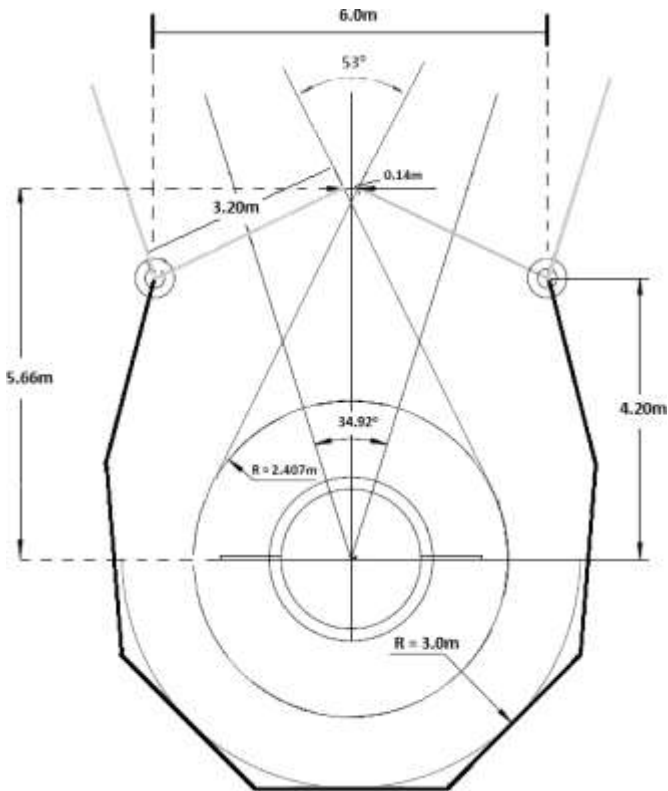
**Figure (c) Rule 37 TR (Rule 192) - Cage for Hammer and Discus Throw with separate circles**  
(With cage dimensions to netting)



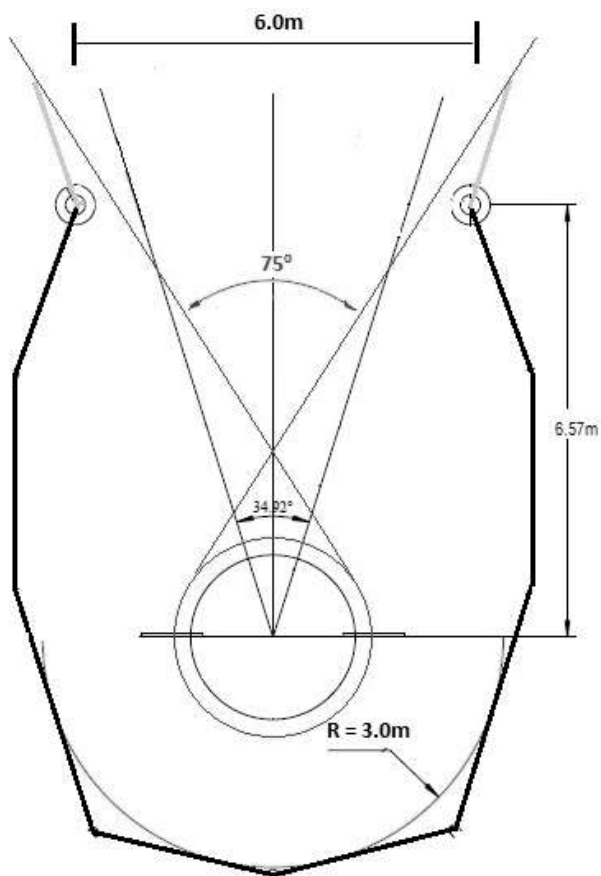
**Figure (d) 37 Rule TR (Rule 192) S1 - pre-November 2018 UKA specification two-circle cage converted to single circle (Hammer throw configuration)**



**Figure (e) Rule 37 TR (Rule 192) S1 - pre-November 2018 UKA specification two-circle cage with modified gates (Hammer throw configuration)**

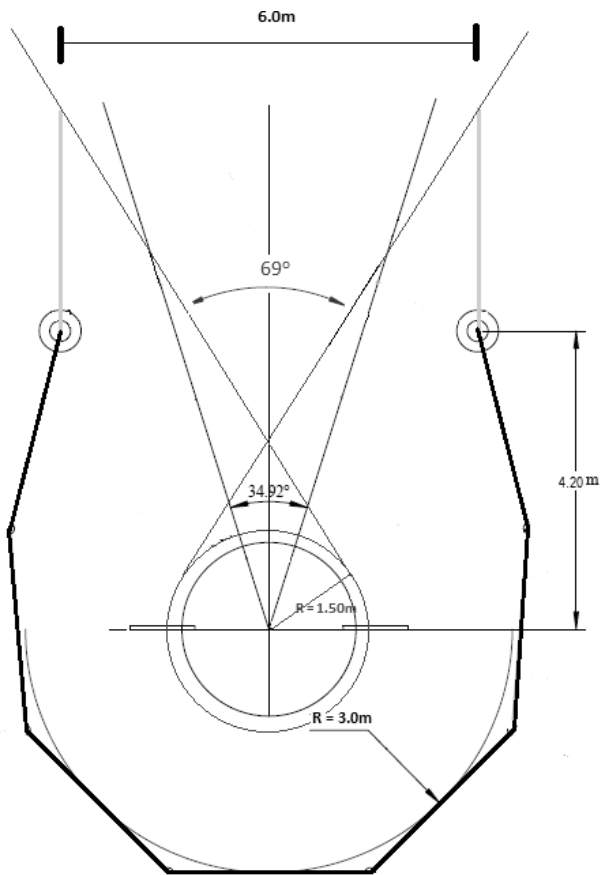


**Figure (f) Rule 37 TR (Rule 192) S1 - pre-November 2018 UKA specification single circle cage with modified gates (Hammer throw configuration)**



**Figure (g) Rule 37 TR (Rule 192) S1 - pre-November 2018 UKA specification two-circle cage converted to single circle (Discus throw configuration)**





**Figure (h) Rule 37 TR (Rule 192) S1 - pre-November 2018 UKA specification single circle cage with modified gates (Discus throw configuration)**

4. Two movable netting panels 2m wide shall be provided at the front of the cage, only one of which will be operative at a time. The minimum height of the panels shall be 10m.

### **RULE T37 (192) S 2 UKA SUPPLEMENT GATE PANELS**

1. For modified UKA specification cages where the distance from the centre of the hammer circle to the cage opening is less than 7metres the minimum height of the gate panels can be 9m. Note: Any hammer cage where the distance from the centre of the hammer circle to the cage opening is 7m or greater must have gate panels that are a minimum of 10metres in height.
2. Cage gate width and operative / closed gate fixing position are determined by calculating the size and positioning of gates required to achieve a compliant hammer throw danger zone angle (maximum 56°).

*Note (i): The left hand panel is used for throwers turning anti clockwise, and the right hand panel for throwers turning clockwise. In view of the possible need to change over from one panel to the other during the competition, when both left and right-handed throwers are present, it is essential that this changeover should require little labour and be carried out in the minimum of time.*

*Note (ii): The end position of both panels is shown in the plan even though only one panel will be closed at any one time during competition.*

*Note (iii): When in operation, the movable panel shall be exactly in the position shown. Provision shall therefore, be made in the design of the movable panels to lock them in the operative position. It is recommended to mark (either temporarily or permanently) the operative positions of the panels on the ground.*

*Note (iv): The construction of these panels and their operation depends on the overall design of the cage and can be sliding, hinging on a vertical or horizontal axis or dismounting. The only firm requirements are that the panel in operation shall be fully able to stop any hammer striking it and there shall be no danger of a*

*hammer being able to force its way between the fixed and movable panels.*

*Note (v): Innovative designs that provide the same degree of protection and do not increase the danger zone compared with conventional designs may be World Athletics certified.*

5. The netting for the cage can be made from suitable natural or synthetic fibre cord or, alternatively, from mild or high tensile steel wire. The maximum mesh size shall be 45mm for cord netting and 50mm for steel wire.

*Note: Further specifications for the netting and safety inspection procedures are set out in the World Athletics Track and Field Facilities Manual.*

6. Where it is desired to use the same cage for Discus Throw, the installation can be adapted in two alternative ways. Most simply, a 2.135m/2.50m concentric circle may be fitted, but this involves using the same surface in the circle for Hammer Throw and Discus Throw. The hammer cage shall be used for Discus Throw by fixing the movable netting panels clear of the cage opening.

In the case of cages modified in accordance with Rule 37.2(a) S 1 (pre-November 2018 UKA specification single circle cage with increased gate width), both gates must, for Discus Throw, be fixed in a “discus closed” position that is parallel to the sector centreline (as the centre of the circle is only 4.20m from the cage opening), see Figure (h) Rule 37 TR (Rule 192) S1.

In the case of cages modified in accordance with Rule 37.1 S 1 (pre-November 2018 UKA specification two- circle cage, either converted to one combined hammer and discus circle, or with the separate hammer and discus circles retained but gate width increased), the required gate positions for Discus Throw are shown in Figure (g) Rule 37 TR (Rule 192) S1 (a maximum danger zone of 75° is acceptable in this configuration).

For separate circles for Hammer Throw and Discus Throw in the same cage, the two circles shall be placed one behind the other with

the centres 2.37m apart on the centre line of the landing sector and with the discus circle at the front. In that case, the movable netting panels shall be used for Discus Throw in order to lengthen the cage sides.

*Note: The arrangement of the rear panels/draped netting is not important provided the netting is a minimum of 3.50m away from the centre of concentric circles or the hammer circle in case of separate circles (or 3.00m for cages with separate circles built under the Rule in force before 2004 with the discus circle at the back) (see also Rule 37.4 of the Technical Rules).*

In the case of cages modified in accordance with Rule 37.1 S 1 (b) (pre-November 2018 UKA specification two- circle cage, with the separate hammer and discus circles retained but gate width increased), the hammer circle should be positioned at the front, as shown in Figure (e) Rule 37 TR (Rule 192) S1.

7. The maximum danger sector for hammer throws from this cage is approximately 53°, when used by both right and left-handed throwers in the same competition (calculated by assuming that the hammer is released from a circumscribed circle of 2.407m radius). The position and alignment of the cage in the Field of Play is, therefore, critical for its safe use.

*Note: The method used to determine the danger zone is illustrated in Figure (a) Rule 37 of the Technical Rules.*

## **RULE 38 JAVELIN THROW**

### **COMPETITION**

1. The javelin shall be held at the grip with one hand only. It shall be thrown over the shoulder or upper part of the throwing arm and shall not be slung or hurled. Non-orthodox styles are not permitted.
2. A throw shall be valid only if the metal head strikes the ground before any other part of the javelin.
3. Until the javelin has been thrown, an athlete shall not at any time turn completely around, so that their back is towards the throwing arc.

Previous references in the Rules to the “tip” of the javelin have been removed and are replaced by a generic reference to the head. This acknowledges that the shape of the head varies greatly, making it harder to separately define the tip. It means that Judges in determining whether the javelin has landed correctly in terms of Rule 32.16 of the Technical Rules and this Rule 38.2 and the reference point for measurement in terms of Rule 32.20.2 of the Technical Rules now have a bigger area with which to assess. But the principles remain as before and there must be some angle on landing, however small, for the throw to be valid. Flat or “tail-first” landings are still to be red flagged.

4. If the javelin breaks during a throw or while in the air, it shall not count as a failure, provided the trial was otherwise made in accordance with this Rule. Nor shall it count as a failure if an athlete thereby loses their balance and as a result contravenes any part of this Rule. In both cases the athlete shall be awarded a replacement trial.

#### **JAVELIN**

5. The javelin shall consist of three main parts: a shaft, a head and a cord grip.
6. The shaft may be solid or hollow and shall be constructed of metal or other suitable material so as to constitute a fixed and integrated whole. The surface of the shaft shall have no dimples or pimples, grooves or ridges, holes or roughness, and the finish shall be smooth (see Rule 33.4 of the Technical Rules) and uniform throughout.
7. The shaft shall have fixed to it a metal head terminating in a sharp point. The head shall be constructed completely of metal. It may contain a reinforced tip of other metal alloy fixed to the front end of the head provided that the completed head is smooth (see Rule 38.4 of the Technical Rules) and uniform along the whole of its surface. The angle of tip shall not exceed 40 degrees.
8. The cord grip, which shall cover the centre of gravity, shall not exceed the diameter of the shaft by more than 8mm. It may have a regular non-slip pattern surface but without thongs, notches or indentations of any kind. The grip shall be of uniform thickness.
9. The cross-section shall be regularly circular throughout (see Note (i)). The maximum diameter of the shaft shall be immediately in

front of the grip. The central portion of the shaft, including the part under the grip, may be cylindrical or slightly tapered towards the rear but in no case may the reduction in diameter, from immediately in front of the grip to immediately behind, exceed 0.25mm. From the grip, the javelin shall taper regularly to the tip at the front and the tail at the rear. The longitudinal profile from the grip to the front tip and to the tail shall be straight or slightly convex (see Note (ii)), and there shall be no abrupt alteration in the overall diameter, except immediately behind the head and at the front and rear of the grip, throughout the length of the javelin. At the rear of the head, the reduction in the diameter may not exceed 2.5mm and this departure from the longitudinal profile requirement may not extend more than 0.3m behind the head.

*Note (i): Whilst the cross section throughout should be circular, a maximum difference between the largest and the smallest diameter at any cross section of 2% is permitted. The mean value of these two diameters, at any nominated cross section, shall meet the specifications of a circular javelin in the tables hereunder.*

*Note (ii): The shape of the longitudinal profile may be quickly and easily checked using a metal straight edge at least 500mm long and two feeler gauges 0.20mm and 1.25mm thick. For slightly convex sections of the profile, the straight edge will rock while being in firm contact with a short section of the javelin. For straight sections of the profile, with the straight edge held firmly against it, it must be impossible to insert the 0.20mm gauge between the javelin and the straight edge anywhere over the length of contact. This shall not apply immediately behind the joint between the head and the shaft. At this point it must be impossible to insert the 1.25mm gauge.*

10. The javelin shall conform to the following specifications:  
Minimum weight for admission to competition and acceptance of a Record (inclusive of the cord grip):

	500g	600g	700g	800g
Overall length (L0):				
Minimum	2000mm	2200mm	2300mm	2600mm
Maximum	2100mm	2300mm	2400mm	2700mm
Distance from tip of metal head to centre of gravity (L1):				
Minimum	780mm	800mm	860mm	900mm
Maximum	880mm	920mm	1000mm	1060mm
Distance from tail to centre of gravity (L2):				
Minimum	1120mm	1280mm	1300mm	1540mm
Maximum	1320mm	1500mm	1540mm	1800mm
Length of metal head (L3):				
Minimum	220mm	250mm	250mm	250mm
Maximum	270mm	330mm	330mm	330mm
Width of cord grip (L4):				
Minimum	135mm	140mm	150mm	150mm
Maximum	145mm	150mm	160mm	160mm
Diameter of shaft at thickest point (in front of grip - D0):				
Minimum	20mm	20mm	23mm	25mm
Maximum	24mm	25mm	28mm	30mm

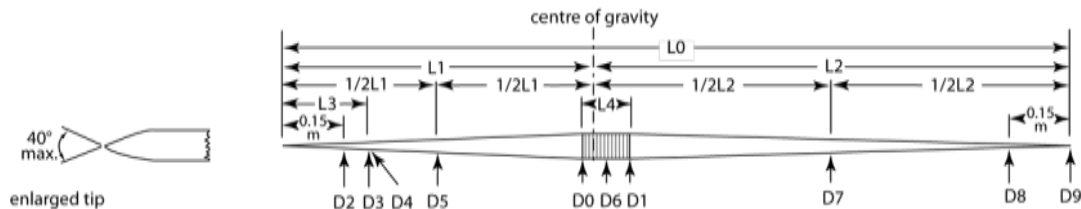
**RULE T38 (193) S 1 UKA SUPPLEMENT  
JAVELIN SPECIFICATIONS FOR  
NON- WORLD ATHLETICS AGE GROUPS**

MEN	UNDER 17		UNDER 15		UNDER 13	
	Min	Max	Min	Max	Min	Max
Weight (incl of cord grip)	700g		600g		400g	
Length	2300mm	2400mm	2200mm	2300mm	1700mm	1950mm
Length of metal head	250mm	330mm	250mm	330mm	200mm	300mm
Distance from tip of metal head to centre of gravity	860mm	1000mm	800mm	920mm	700mm	850mm
Diameter at thickest point	23mm	28mm	20mm	25mm	19mm	24mm
Whipcord Width	150mm	160mm	140mm	150mm	130mm	140mm
<b>WOMEN</b>						
	UNDER 17 UNDER 15		UNDER 13			
	Min	Max	Min	Max		
Weight (incl of cord grip)	500g		400g			
Length	2000mm	2100mm	1700mm	1950mm		
Length of metal head	220mm	270mm	200mm	300mm		
Distance from tip of metal head to centre of gravity	780mm	880mm	700mm	850mm		
Diameter at thickest point	20mm	24mm	19mm	24mm		
Whipcord Width	135mm	145mm	130mm	140mm		



<b>MASTERS</b>	<b>MEN 35 - 49</b>	<b>MEN 50 - 59</b>	<b>MEN 60 - 69</b>	<b>MEN 70 - 79</b>	<b>MEN 80+</b>
Weight (incl of cord grip)	800g	700g	600g	500g	400g
	<b>WOMEN 35 - 49</b>	<b>WOMEN 50 - 74</b>	<b>WOMEN 75+</b>		
Weight (incl of cord grip)	600g	500g	400g		

11. The javelin shall have no mobile parts or other apparatus, which during the throw could change its centre of gravity or throwing characteristics.
12. The tapering of the javelin to the tip of the metal head shall be such that the angle of the point shall be not more than 40°. The diameter, at a point 0.15m from the tip, shall not exceed 80% of the maximum diameter of the shaft. At the midpoint between the centre of gravity and the tip of the metal head, the diameter shall not exceed 90% of the maximum diameter of the shaft.
13. The tapering of the shaft to the tail at the rear shall be such that the diameter, at the midpoint between the centre of gravity and the tail, shall not be less than 90% of the maximum diameter of the shaft. At a point 0.15m from the tail, the diameter shall be not less than 40% of the maximum diameter of the shaft. The diameter of the shaft at the end of the tail shall not be less than 3.5mm.



**Figure Rule 38 TR (Rule 193) - International Javelin**

Lengths		Diameters		Maximum	Minimum
L0	Overall	D0	In front of grip	–	–
L1	Tip to C of G	D1	At rear of grip	D0	D0-0.25mm
1/2L1	Half L1	D2	150mm from tip	0.8 D0	–
L2	Tail to C of G	D3	At rear of head	–	–
1/2L2	Half L2	D4	Immediately behind head	–	D3-2.5mm
L3	Head	D5	Half way tip to C of G	0.9 D0	–
L4	Grip	D6	Over grip	D0+8mm	–
		D7	Half way tail to C of G	–	0.9 D0
		D8	150mm from tail	–	0.4 D0
		D9	At tail	–	3.5mm
	C of G Centre of Gravity				

### Team of Officials

For a Javelin Throw event, it is recommended to allocate the available officials as follows:

- a. The Chief Judge will watch over the whole of the event.
- b. Two Judges checking whether the throw has been made correctly and measuring the trial. One must be provided with two flags - white to indicate if the trial is valid and red if it is a failure. When the throw has been measured, it is advised that the Judge stands on the runway holding the red flag, while the implement is returned and the landing area is cleared. A cone may be placed on the runway instead. (In some competitions this position is assumed by the Chief Judge of the event.)
- c. Where EDM is not in use the second Judge should pull through and hold the measuring tape in such a way that it passes through the 8m point marked on the runway.
- d. one or two Judges immediately after the throw placing a marker indicating the point from which the trial is to be measured. If the implement lands outside the sector either this Judge or the one with the spike/prism (whichever is closer to the line) should indicate this by holding their arm outstretched. An appropriate indication is also required if these Judges determine that the implement has not landed "head first". It is recommended that some form of signal other than flags is used for this purpose. No indication is required for a valid trial.
- e. Judge positioning the spike/prism at the point where the marker has been placed ensuring the tape is on the zero mark.
- f. one or more Judges or assistants in charge of retrieving the implements and returning them to the implement stand or placing them in the return device. Where a tape is used for measurement, one of these Judges or assistants should ensure that the tape measure is taut in order to ensure a correct measurement.
- g. Judge - a recorder scoring the results sheet and calling each athlete (and the one who is to follow).
- h. Judge in charge of the scoreboard (trial-number-result).

- i. Judge in charge of the clock indicating to the athletes that they have a certain time to take their trial.
- j. Judge in charge of athletes.
- k. Judge in charge of the implement stand.

*Note (i): This is the traditional setting-up of the officials. In major competitions, where a data system and electronic scoreboards are available, specialised personnel are certainly required. To be clear in these cases, the progress and scoring of a Field Event is followed by both the recorder and by the data system.*

*Note (ii): Officials and equipment must be placed in such a way as not to obstruct the athlete's way nor impede the view of the spectators.*

*Note (iii): A space must be reserved for a wind-sock to indicate the wind direction and strength.*

## SECTION IV – COMBINED EVENTS COMPETITIONS

### RULE 39 COMBINED EVENTS COMPETITIONS

#### U18, U20 AND SENIOR MEN (PENTATHLON AND DECATHLON)

1. The Pentathlon consists of five events which shall be held on one day in the following order: Long Jump; Javelin Throw; 200m; Discus Throw; and 1500m.
2. The Men's Decathlon consists of ten events which shall be held on two consecutive 24-hour periods in the following order:  
First day: 100m; Long Jump; Shot Put; High Jump; 400m.  
Second day: 110m Hurdles; Discus Throw; Pole Vault; Javelin Throw; 1500m.

#### U20 AND SENIOR WOMEN (HEPTATHLON AND DECATHLON)

3. The Heptathlon consists of seven events, which shall be held on two consecutive 24-hour periods in the following order:  
First day: 100m Hurdles; High Jump; Shot Put; 200m.  
Second day: Long Jump; Javelin Throw; 800m.
4. The Women's Decathlon consists of ten events which shall be held on two consecutive 24-hour periods in the order of Rule 39.2 or in the following order:  
First day: 100m; Discus Throw; Pole Vault; Javelin Throw; 400m.  
Second day: 100m Hurdles; Long Jump; Shot Put; High Jump; 1500m.
5. The U18 Women's Heptathlon consists of seven events, which shall be held on two consecutive 24-hour periods in the following order:  
First day: 100m Hurdles; High Jump; Shot Put; 200m.  
Second day: Long Jump; Javelin Throw; 800m.

#### GENERAL

6. At the discretion of the Combined Events Referee, there shall, whenever possible, be an interval of at least 30 minutes between the time one event ends and the next event begins, for any individual athlete. If possible, the time between the finish of the last event on the first day and the start of the first event on the second day should be at least 10 hours.

The minimum period of 30 minutes is to be calculated as being the actual time between the end of the last race or trial for any athlete in the previous event to the start of the first race or trial in the next event. It is therefore possible and not uncommon for athletes to go directly from the conclusion of one event to the warm-up for the next so that the 30 minutes is in effect taken up by the movement from one site to another and the warm-up. Changes in the number of days over which a Combined Events competition is conducted are not allowed except for special cases (e.g. exceptional weather conditions). Such decisions are matters for the Technical Delegates and/or Referees in the particular circumstances of each case. However, if, for any reason, the competition is held for a longer period than according to Rules 39 or 53 of the Technical Rules then a record in Combined Events (total number of points) cannot be ratified.

7. In each separate event, except the last, of a Combined Events competition, the heats and groups shall be arranged by the Technical Delegate(s) or Combined Events Referee, as applicable, so that the athletes with similar performances in each individual event during a predetermined period, shall be placed in the same heat or group. Preferably five or more, and never less than three, athletes shall be placed in each heat or group. When this cannot be achieved because of the timetable of events, the heats or groups for the next event should be arranged as and when athletes become available from the previous event.

In the last event of a Combined Events competition, the heats should be arranged so that the last one contains the leading athletes after the penultimate event.

The Technical Delegate(s) or the Combined Events Referee shall have the authority to rearrange any group if, in their opinion, it is desirable.

8. The Rules for each event constituting the competition will apply with the following exceptions:
  - 8.1 in the Long Jump and each of the throwing events, each athlete shall be allowed three trials only.

- 8.2 in case a Fully Automatic Timing and Photo Finish System is not available, each athlete's time shall be taken by three Timekeepers independently.
- 8.3 in the Track Events, only one false start per race shall be allowed without the disqualification of the athlete(s) responsible for the false start. Any athlete(s) responsible for further false starts in the race shall be disqualified by the Starter (see also Rule 16.9 of the Technical Rules).
- 8.4 in the Vertical Jumps, each increase of the bar shall be uniform throughout the competition: 3cm in the High Jump and 10cm in the Pole Vault.
- 8.5 starting positions / lanes for last event of a Combined Events competition may be determined by the Technical Delegate(s) or the Combined Events Referee as they deem desirable. In all other events they shall be drawn by lot.
9. Only one system of timing may be applied throughout each individual event. However, for Record purposes, times obtained from a Fully Automatic Timing and Photo Finish system shall be applied regardless of whether such times are available for other athletes in the event.

Two systems of timekeeping are recognised for this purpose – those set out in Rule 19.1.1 and 19.1.2 of the Technical Rules.

If for example there is a malfunction of Photo Finish being used for some but not all of the heats it will be impossible to compare directly the points scores in the two systems for the same time - one by Hand Time and the other automatic.

Since under Rule 39.9 of the Technical Rules, only one system of timing may be applied throughout any single event in a competition, in such a case all athletes would have their points determined based on their manual times using the specific manual times table.

To be clear, if in other events all athletes have Photo Finish times, the electronic times table can be used for those events.

10. Any athlete failing to attempt to start or make a trial in one of the events shall not be allowed to take part in the subsequent events but

shall be considered to have abandoned the competition. They shall not, therefore, figure in the final classification.

Any athlete deciding to withdraw from a Combined Events competition shall immediately inform the Combined Events Referee of their decision.

11. The scores, according to the current Combined Events Scoring Tables, shall be announced, separate for each event and as a cumulative total, to all athletes after the completion of each event. The athletes shall be placed in order according to the total number of points obtained.

The same Scoring Tables are used for each event even if for the younger age groups the specifications for the hurdles or throwing implements differ from those used for senior competition.

The score for any performance in either a Track Event or a Field Event can be found in the appropriate table. In many events, not all possible times or distances are listed in the table. In such cases, the score for the nearest lesser performance shall be used.

Example: For the women's Javelin Throw there is no points score shown for a distance of 45.82m. The nearer shorter distance listed in the table is 45.78m for which there is a score of 779 points.

12. When it is decided to use the Gundersen (or similar) Method for the start of the last event of a Combined Events competition, the relevant competition regulations should specify any particular rules that should be applied and the method by which the races should be started and conducted.
13. If two or more athletes achieve an equal number of points for any place in the competition, it shall be determined as a tie.



**RULE T39 (200) S 1 UKA SUPPLEMENT  
COMBINED EVENTS FOR AGE GROUPS YOUNGER THAN  
WORLD ATHLETICS AGE GROUPS**

(1) The Outdoor Pentathlon for Under 15 Boys consists of five events which may be held on one day or on two consecutive days in the following order: 80 metres Hurdles, Putting the Shot, Long Jump, High Jump, 800 metres.

(2) The Outdoor Pentathlon for Under 15 Girls consists of five events which should be held on one day or on two consecutive days in the following order: Long Jump, 75 metres Hurdles, Putting the Shot, (break of one hour), High Jump, 800 metres.

*NOTE: If practicable, there should be at least a 30 minute break between events. If the Pentathlon is held on one day the competition should be split into two sessions with a break of one hour between each session.*

(3) The Hexathlon for Under 15 Girls consists of six events which shall be held over two days; 75 metres Hurdles (which shall begin the first day), Long Jump, Throwing the Javelin, High Jump, Putting the Shot, 800 metres (which shall be the final event).

(4) The Outdoor Heptathlon for Under 17 Women shall be held on two consecutive days in the following order: first day: 80 metres Hurdles, High Jump, Putting the Shot, 200 metres. Second day: Long Jump, Throwing the Javelin, 800 metres but the Hurdle event specifications shall be those relating to this age group and the order of events shall be flexible.

(5) The Outdoor Octathlon for Under 17 Men shall consist of the following eight events held over two days: High Jump, Long Jump, Putting the Shot, Throwing the Discus, Throwing the Javelin, 100 metres Hurdles, 400 metres (which shall conclude the first day's programme) and 1500 metres (which shall be the final event).

(6) The Outdoor Octathlon for Under 15 Boys shall consist of the following eight events held over two days: 100 metres (which shall begin the first day), 80 metres Hurdles, High Jump, Pole Vault, Throwing the Discus, Throwing the Javelin, 400 metres (which shall conclude the first day's programme), and 1000 metres (which shall be the final event).

(7) Where races are hand timed at any Combined Event competition, regardless of age group, the World Athletics practice of adjusting times by 0.24 secs and 0.14 secs should not be applied.

## SECTION V – INDOOR COMPETITIONS

### **RULE 40 APPLICABILITY OF OUTDOOR RULES TO INDOOR COMPETITIONS**

With the exceptions stated in the following Rules of this Section V and the requirement for wind measurement set out in Rules 17 and 29 of the Technical Rules, the Rules of Parts I to V for outdoor competitions shall apply to Indoor Competitions.

### **RULE 41 THE INDOOR STADIUM**

1. The stadium shall be completely enclosed and covered. Lighting, heating and ventilation shall be provided to give satisfactory conditions for competition.
2. The Field of Play should include an oval track; a straight track for sprints and hurdles; runways and landing areas for jumping events. In addition, a circle and landing sector for the Shot Put should be provided, whether permanently or temporarily. All the facilities should conform to the specifications in the World Athletics Track and Field Facilities Manual.
3. All the tracks, runways or take-off surface areas shall be covered with a synthetic material that should preferably be able to accept 6mm spikes in running shoes.  
Alternative thicknesses may be provided by the stadium management, who will notify athletes of the permissible length of spikes. (See Rule 5.4 of the Technical Rules).  
Indoor Track and Field competitions under paragraphs 1.1, 1.2, 1.3 and 1.6 of the International Competition definition should be held only on facilities that hold a World Athletics Indoor Athletics Facility Certificate. It is recommended that, when such facilities are available, competitions under paragraphs 1.4, 1.5, 1.7, 1.8, 1.9 and 1.10 of the International Competition definition should also be held on these facilities.
4. The foundation on which the synthetic surface of the tracks, runways and take-off areas is laid shall be either solid e.g. concrete or, if of suspended construction (such as wooden boards or plywood sheets mounted on joists), without any special sprung sections and, as far as technically possible, each runway shall have a uniform resilience

throughout. This shall be checked, for the take-off area for the jumps, before each competition.

*Note (i): A "sprung section" is any deliberately engineered or constructed section designed to give extra assistance to an athlete.*

*Note (ii): The World Athletics Track and Field Facilities Manual, which is available from the World Athletics Office, or may be downloaded from the World Athletics website, contains more detailed and defined specifications for planning and construction of indoor stadia including diagrams for track measurement and marking.*

*Note (iii): The current standard forms required to be used for the certification application and measurement report as well as the Certification System Procedures are available from the World Athletics Office or may be downloaded from the World Athletics website.*

Lack of suitable lighting is a common problem for Indoor Competitions. A covered stadium must have a lighting which allows a correct and fair delivery of the events and if there is television coverage the illumination level may need to be higher. The finish line area(s) may require additional lighting for the Filly Automatic Timing.

## **RULE 42 THE STRAIGHT TRACK**

|| [See the rules for outdoor competitions and the World Athletics Track and Field Facilities Manual.]

## **RULE 43 THE OVAL TRACK AND LANES**

1. The nominal length should preferably be 200m. It shall consist of two parallel straights and two bends, which may be banked, whose radii should be equal.

The inside of the track shall be bordered either with a kerb of suitable material, approximately 50mm in height and width, or with a white line 50mm wide. The outside edge of this kerb or line forms the inside of lane 1. The inside edge of the kerb or line shall be horizontal throughout the length of the track with a maximum slope

of 1:1000 (0.1%). The kerb on the two straights may be omitted, and a white line 50mm wide substituted.

*Note: All measurements shall be taken as indicated in Rule 14.2.*

### **LANES**

2. The track should have a minimum of four and a maximum of six lanes. The nominal width of the lanes shall be between 0.90m and 1.10m including the lane line on the right. All lanes shall be of the same nominal width with a tolerance of  $\pm 0.01\text{m}$  to the selected width. The lanes shall be separated by white lines 50mm wide.

### **BANKING**

3. The angle of banking in all the lanes in the bend and, separately, in the straight, should be the same at any cross section of the track. The straight may be flat or have a maximum lateral inclination of 1:100 (1%) towards the inside lane.

In order to ease the change from the straight to the banked bend, the change may be made with a smooth gradual horizontal transition which may be extended into the straight. In addition, there should be a vertical transition.

### **MARKING OF THE INSIDE EDGE**

4. Where the inside edge of the track is bordered with a white line, it shall be marked additionally with cones or flags on the bends and, optionally, on the straights. The cones shall be at least 0.15m high. The flags shall be approximately  $0.25\text{m} \times 0.20\text{m}$  in size, at least 0.45m high and set at an angle of  $60^\circ$  with the ground away from the track. The cones or flags shall be placed on the white line so that the edge of the base of the cone or flag pole coincides with the edge of the white line closest to the track. The cones or flags shall be placed at intervals not exceeding 1.5m on the bends and, if used, 10m on the straights.

*Note: For all indoor competitions directly under World Athletics, the use of an inside kerb is strongly recommended.*

An Oval Track may be longer than 200m but any records for 200m or longer races would not be ratified. To organise top level competitions, it will be useful to have a 6 lane track. The ideal width of the lanes of an Oval Track should be 1m.

When positioning the flags or cones it must be taken into account that the white line on the inside edge of lane 1 does not belong to the runner drawn in that lane. Cones are preferred and recommended for Indoor Competitions.

#### **RULE 44 START AND FINISH ON THE OVAL TRACK**

1. Technical information on the construction and marking of a 200m banked indoor track are given in detail in the World Athletics Track and Field Facilities Manual. The basic principles to be adopted are given hereunder.

#### **BASIC REQUIREMENTS**

2. The start and finish of a race shall be denoted by white lines 50mm wide, at right angles to the lane lines for straight parts of the track and along a radius line for curved parts of the track.
3. The requirements for the finish line are that, if at all possible, there should be only one for all the different lengths of race, it shall be on a straight part of the track and as much of that straight as possible should be before the finish.
4. The essential requirement for all start lines, straight, staggered or curved, is that the distance for every athlete, when taking the shortest permitted route, shall be the same.
5. As far as possible, start lines (and takeover zone lines for Relay Races) should not be on the steepest part of the banking.

#### **CONDUCT OF THE RACES**

6. Conduct of the Races, as follows:
  - 6.1 Races of up to, and including, 300m shall be run entirely in lanes.

*NOTE: 300m races shall start and continue in lanes until the break line marked at the end of the second bend.*

- 6.2 Races over 300m, and less than 800m shall start and continue in lanes until the breakline marked at the end of the second bend.
- 6.3 For the start of races of 800m, each athlete may be assigned a separate lane, or up to two athletes may be assigned per lane, or a group start, as in Rule 17.5.2 of the Technical Rules preferably commencing in lanes 1 and 4, may be used. In

these cases, athletes may leave their lane, or those running in the outer group may join the inner group, only after the breakline marked at the end of the first bend, or if the race is run with two bends in lanes, at the end of the second bend. A single curved start line may also be used.

- 6.4 Races longer than 800m shall be run without lanes using an arced start line or group starts. If a group start is used, the breakline shall be at the end of either the first or second bend.

*NOTE: A (single) arced start may be used for 800m races.*

If an athlete does not follow this Rule, they shall be disqualified. The breakline shall be an arced line marked after each bend, 50mm wide, across all lanes other than lane 1. To assist athletes identify the breakline, small cones, prisms or other suitable markers, 50mm × 50mm and no more than 0.15m high, preferably of different colour from the breakline and the lane lines, shall be placed on the lane lines immediately before the intersection of the lane lines and the breakline.

*Note (i): In competitions other than those held under paragraphs 1.1, 1.2, 1.3 and 1.6 of the International Competition definition, the participating teams may agree not to use lanes for the 800m event.*

*Note (ii): On tracks with less than six lanes, a group start may be used to allow six athletes to compete.*

## **START LINE AND FINISH LINE FOR A TRACK OF 200M NOMINAL LENGTH**

7. The start line in lane 1 should be on the principal straight. Its position shall be determined so that the most advanced staggered start line in the outside lane (400m races) should be in a position where the angle of banking should not be more than 12 degrees. The finish line for all races on the oval track shall be an extension of the start line in lane 1, right across the track and at right angles to the lane lines.

Colours to use for marking the track are indicated on the Track Marking Plan included in the World Athletics Track and Field Facilities Manual.

## **RULE 45 SEEDINGS AND DRAW FOR LANES IN TRACK EVENTS**

1. The ranking and composition of heats shall be made in accordance with Rule 20.3 of the Technical Rules.
2. For all rounds in all events run wholly or partly in lanes around a bend, where there are successive rounds of a race, three draws for lanes will then be made:
  - 2.1 one for the two highest ranked athletes or teams to determine placings in the outer two lanes;
  - 2.2 another for the third and fourth ranked athletes or teams to determine placings in the next two lanes;
  - 2.3 another for the other athletes or teams to determine placings in any remaining inner lanes.
3. For all other races, the lane order shall be drawn in accordance with Rules 20.4.1-20.4.2 and 20.5 of the Technical Rules.

Where tracks have a different configuration of lanes, then the tables to be used should be adapted either in the specific Technical Regulations for the competition or if not by the Technical Delegate(s) or the Organisers.

## **RULE 46 CLOTHING, SHOES AND ATHLETE BIBS**

That part of each spike which projects from the sole or the heel shall not exceed 6mm (or as required by the Organisers) subject always to the maxima provided in Rule 5.4 of the Technical Rules.

**RULE 47 HURDLE RACES**

1. The standard distances shall be: 50m or 60m on the straight track.
2. Layout of the hurdles for races:

	U18 Boys	U20 Men	Men	U18 Girls	U20 Women/ Women
Height of hurdle	0.914m	0.991m	1.067m	0.762m	0.838m
Distance	50m/60m				
Number of hurdles	4/5				
Start line to first hurdle	13.72m			13.00m	
Between hurdles	9.14m			8.50m	
Last hurdle to finish line	8.86m/9.72m			11.50m/13.00m	

See Rule T22 (168) S1 for UK Indoor Hurdles Specifications

**RULE 48 RELAY RACES****CONDUCT OF THE RACES**

1. In the 4 × 200m race, all the first leg and the first bend of the second leg up to the nearer edge of the breakline described in Rule 44.6 of the Technical Rules, shall be run in lanes. Each takeover zone shall be 20m long and the second, third and fourth athlete shall start within this zone.
2. The 4 × 400m race shall be run according to Rule 44.6.2 of the Technical Rules.
3. The 4 × 800m race shall be run according to Rule 44.6.3 of the Technical Rules.
4. The waiting athletes in the third and fourth legs of the 4 × 200m race, in the second, third and fourth legs of the 4 × 400m and the 4 × 800m race shall, under the direction of a designated official, place themselves in their waiting position in the same order (inside to out) as the order of their respective team members as they enter the last bend. Once the incoming athletes have passed this point, the waiting athletes shall maintain their order, and shall not exchange positions at the beginning of the takeover zone. If an athlete does not follow this Rule, their team shall be disqualified.



*Note: Owing to the narrow lanes, indoor Relay Races are much more liable to collisions and unintended obstruction than outdoor Relay Races. It is, therefore, recommended that, when possible, a spare lane should be left between each team.*

## **RULE 49 HIGH JUMP**

### **RUNWAY AND TAKE-OFF AREA**

1. If portable mats are used, all references in the Rules to the level of the take-off area must be construed as referring to the level of the top surface of the mat.
2. An athlete may start their approach on the banking of the oval track provided that the last 15m of their run up is on a runway complying with Rules 27.3, 27.4 and 27.5 of the Technical Rules.

## **RULE 50 POLE VAULT**

### **RUNWAY**

An athlete may start their approach on the banking of the oval track provided that the last 40m of their run up is on a runway complying with Rules 28.6 and 28.7 of the Technical Rules.

## **RULE 51 HORIZONTAL JUMPS**

### **RUNWAY**

An athlete may start their approach on the banking of the oval track provided that the last 40m of their run up is on a runway complying with Rules 29.1 and 29.2 of the Technical Rules.

## **RULE 52 SHOT PUT**

### **LANDING SECTOR**

1. The landing sector shall consist of some suitable material on which the shot will make an imprint, but which will minimise any bounce.
2. Where necessary to ensure the safety of spectators, officials and athletes, the landing sector shall be enclosed at the far end and on the two sides by a stop barrier and/or protective netting, placed as close to the circle as required. The recommended minimum height of the netting should be 4m and sufficient to stop a shot, whether in flight or bouncing from the landing surface.

3. In view of the limited space in an indoor Field of Play, the area enclosed by the stop barrier may not be large enough to include a full 34.92° sector. The following conditions shall apply to any such restriction.
  - 3.1 The stop barrier at the far end shall be at least 0.50m beyond the current World Record in Shot Put for men or women.
  - 3.2 The sector lines on either side shall be symmetrical about the centre line of the 34.92° sector.
  - 3.3 The sector lines may either run radially from the centre of the Shot Put circle including a full 34.92° sector or may be parallel to each other and the centre line of the 34.92° sector. Where the sector lines are parallel, the minimum separation of the two sector lines shall be 9m.

It is recommended that the stop barrier / protective netting on either side should be extended towards the circle so that it starts within 8m of it and that, for the length of these extensions, the height of the netting should be at least 5m.

### **CONSTRUCTION OF THE SHOT**

4. Depending on the type of landing area (see Rule 52.1 of the Technical Rules), the shot shall be either solid metal or metal cased or, alternatively, soft plastic or rubber casing with a suitable filling. Both types of shot may not be used in the same competition.

#### **SOLID METAL OR METAL CASED SHOT**

5. These shall comply with Rule 33.4 and 33.5 of the Technical Rules, for the Shot Put outdoors.

#### **PLASTIC OR RUBBER CASED SHOT**

6. The shot shall have a soft plastic or rubber case with a suitable filling such that no damage shall be caused when landing on a normal sports hall floor. It shall be spherical in shape and its surface finish shall be smooth.

Information for manufacturers: to be smooth, the surface average height must be less than 1.6µm, i.e. a roughness number N7 or less.

7. The shot shall conform to the following specifications:  
Minimum weight for admission to competition and acceptance of a Record:

	3.000kg	4.000kg	5.000kg	6.000kg	7.260kg
Diameter:					
Minimum	85mm	95mm	100mm	105mm	110mm
Maximum	120mm	130mm	135mm	140mm	145mm

## **RULE 53 COMBINED EVENTS COMPETITIONS**

### **U18, U20 AND SENIOR MEN (PENTATHLON)**

1. The Pentathlon consists of five events, which shall be held on one day in the following order:  
60m Hurdles; Long Jump; Shot Put; High Jump; 1000m.

### **U18, U20 AND SENIOR MEN (HEPTATHLON)**

2. The Heptathlon consists of seven events which shall be held over two consecutive 24 hour periods in the following order:  
First day: 60m; Long Jump; Shot Put; High Jump.  
Second day: 60m Hurdles; Pole Vault; 1000m.

### **U18, U20 AND SENIOR WOMEN (PENTATHLON)**

3. The Pentathlon consists of five events and shall be held on one day in the following order:  
60m Hurdles; High Jump; Shot Put; Long Jump; 800m.

### **HEATS AND GROUPS**

4. Preferably four or more, and never less than three, athletes shall be placed in each heat or group.

## SECTION VI – RACE WALKING EVENTS

### RULE 54 RACE WALKING

#### DISTANCES

1. The standard distances shall be: indoor: 3000m, 5000m; outdoor: 5000m, 10km, 10,000m, 20km, 20,000m, 50km, 50,000m.

#### DEFINITION OF RACE WALKING

2. Race Walking is a progression of steps so taken that the walker makes contact with the ground, so that no visible (to the human eye) loss of contact occurs. The advancing leg must be straightened (i.e. not bent at the knee) from the moment of first contact with the ground until the vertical upright position.

#### JUDGING

3. Judging, as follows:
  - 3.1 The appointed Judges of Race Walking shall elect a Chief Judge, if one has not been appointed previously.
  - 3.2 All the Judges shall act in an individual capacity and their judgements shall be based on observations made by the human eye.
  - 3.3 In competitions held under paragraph 1.1 of the International Competition definition, all Judges shall be International Race Walking Judges. In competitions held under paragraphs 1.2, 1.3, 1.5, 1.6, 1.7 and 1.10 of the International Competition definition, all Judges shall be either Area or International Race Walking Judges.
  - 3.4 For Road Races, there should normally be a minimum of six to a maximum of nine Judges including the Chief Judge.
  - 3.5 For Track Races, there should normally be six Judges including the Chief Judge.
  - 3.6 In competitions held under paragraph 1.1 of the International Competition definition not more than one Judge (excluding the Chief Judge) affiliated with any one Member can officiate.

*Note: The Member affiliation of each Judge is that properly stated on the current lists of Area and International Race Walking Judges.*

### **RULE 54 (230) S 1 UKA SUPPLEMENT**

All walking races must be judged by judges holding a UKA officials' licence for Race Walk judging. The responsibility for ensuring that races are properly judged rests with the Competition Provider who, if unable to find the judges from within his/her own Club, should apply to the appropriate National Judges' Secretary for judges. Any application for judges must include details of the status of the race(s) so that judges of an appropriate grade can be provided. Applications should be made at least three months before the date of the race(s).

The system of judging set out in World Athletics Rule T54.4-6 (World Athletics system) must be used in all UKA Championships. Additionally this system should be adopted in other races with the following exceptions:

- when there are fewer than three judges in attendance,
- relays,
- point-to-point races.

The power of the Chief Judge to disqualify in the last 100m described in Rule T54.4.1 shall be applied to all UK, National and Regional championships.

#### **CHIEF JUDGE**

4. Chief Judge, as follows:

- 4.1 In competitions held under paragraphs 1.1, 1.2, 1.3, 1.4 and 1.6 of the International Competition definition, the Chief Judge has the power to disqualify an athlete in the last 100m, when their mode of progression obviously fails to comply with Rule 54.2 of the Technical Rules regardless of the number of previous Red Cards the Chief Judge has received on that athlete. An athlete who is disqualified by the Chief Judge under these circumstances shall be allowed to finish the race. They shall be notified of this disqualification by the Chief Judge or a Chief Judge's Assistant by showing the

- athlete a red paddle at the earliest opportunity after the athlete has finished the race.
- 4.2 The Chief Judge shall act as the supervising official for the competition, and act as a Judge only in the special situation noted in Rule 54.4.1. In competitions held under paragraphs 1.1, 1.2, 1.3 and 1.6 of the International Competition definition, two or more Chief Judge's Assistants shall be appointed. The Chief Judge's Assistant(s) are to assist with the notification of disqualifications only and shall not act as Race Walking Judges.
- 4.3 For all competitions held under paragraphs 1.1, 1.2, 1.3 and 1.6 of the International Competition definition and where possible for other competitions, an official in charge of the Posting Board(s) and a Chief Judge's Recorder shall be appointed.

### **YELLOW PADDLE**

5. When a Judge is not completely satisfied that an athlete is fully complying with Rule 54.2 of the Technical Rules, they should, where possible, show the athlete a yellow paddle with the symbol of the offence on each side.
- An athlete cannot be shown a second yellow paddle by the same Judge for the same offence. Having shown a yellow paddle to an athlete, the Judge shall inform the Chief Judge of their action after the competition.

### **RED CARDS**

6. When a Judge observes an athlete failing to comply with Rule 54.2 of the Technical Rules by exhibiting visible loss of contact or a bent knee during any part of the competition, the Judge shall send a Red Card to the Chief Judge.

### **DISQUALIFICATION**

7. Disqualification, as follows:
- 7.1 Except as provided in Rule 54.7.3 of the Technical Rules, when three Red Cards from three different Judges have been sent to the Chief Judge on the same athlete, the athlete is disqualified and they shall be notified of this disqualification by the Chief Judge or a Chief Judge's Assistant by being

shown a red paddle. The failure to give notification shall not result in the reinstatement of a disqualified athlete.

- 7.2 In competitions under paragraphs 1.1, 1.2, 1.3 or 1.5 of the International Competition definition, in no circumstances shall the Red Cards of two Judges affiliated with the same Member have the power to disqualify.

*Note: The Member affiliation of each Judge is that properly stated on the current lists of Area and International Race Walking Judges.*

- 7.3 A Penalty Zone shall be used for any race where the applicable regulations for the competition so provide and may be used for other races as determined by the relevant governing body or Organisers. In such cases, an athlete will be required to enter the Penalty Zone and remain there for the applicable period once they have received three Red Cards and are so advised by the Chief Judge or someone delegated by them.

The applicable period in the Penalty Zone shall be as follows:

Races up to and including	Time
5000m/5km	0.5 min
10,000m/10km	1 min
20,000m/20km	2 min
30,000m/30km	3 min
40,000m/40km	4 min
50,000m/50km	5 min

An athlete who fails to enter the Penalty Zone when required to do so, or remain there for the applicable period, shall be disqualified by the Referee.

- 7.4 If, under Rule 54.7.3 of the Technical Rules, an athlete receives a third Red Card and it is no longer practicable to direct them to enter the Penalty Zone before the end of the race, the Referee shall add the time they would have been required to spend in the Penalty Zone to their finishing time and adjust the finishing order as may be necessary.
- 7.5 If, at any time when Rule 54.7.3 of the Technical Rules applies, an athlete receives an additional Red Card from a

- Judge other than one of the three who had previously sent a Red Card, they shall be disqualified.
- 7.6 In Track Races, an athlete who is disqualified shall immediately leave the track and, in Road Races, shall, immediately after being disqualified, remove the distinguishing bibs and leave the course. Any disqualified athlete who fails to leave the course or track or comply with directions given under Rule 54.7.3 of the Technical Rules to enter and remain for the required period in the Penalty Zone may be liable to further disciplinary action in accordance with Rule 18.5 of the Competition Rules and Rule 7.2 of the Technical Rules.
- 7.7 One or more Posting Boards shall be placed on the course and near the finish to keep athletes informed about the number of Red Cards that have been sent to the Chief Judge for each athlete. The symbol of each offence should also be indicated on the Posting Board.
- 7.8 For all competitions falling under paragraph 1.1 of the International Competition definition, handheld computer devices with transmission capability must be used by the Judges to communicate all Red Cards to the Recorder and the Posting Board(s). In all other competitions, in which such a system is not used, the Chief Judge, immediately after the end of the event, shall report to the Referee the identification of all athletes disqualified under Rules 54.4.1, 54.7.1 or 54.7.3 of the Technical Rules by indicating the bib identification, the time of the notification and the offences; the same shall be done for all the athletes who received Red Cards.

## **START**

8. The races shall be started by the firing of a gun, cannon, air horn or like device. The commands for races longer than 400m shall be used (Rule 16.2.2 of the Technical Rules). In races which include a large number of athletes, five-minute, three-minute and one-minute warnings before the start of the race should be given. On the



command “On your marks”, the athletes shall assemble on the start line in the manner determined by the organisers. The Starter shall ensure that no athlete has their foot (or any part of their body) touching the start line or the ground in front of it and shall then start the race.

## **SAFETY**

9. The Organisers of Race Walking events shall ensure the safety of athletes and officials. In competitions held under paragraphs 1.1, 1.2, 1.3 and 1.6 of the International Competition definition, the Organisers shall ensure that the roads used for the competition are closed to motorised traffic in all directions.

## **DRINKING / SPONGING AND REFRESHMENT STATIONS IN ROAD EVENTS**

10. Drinking/Sponging and Refreshment Stations in Road Events, as follows:

- 101 Water and other suitable refreshments shall be available at the start and finish of all races.

- 102 For all events of 5km or longer up to and including 10km, water only drinking / sponging stations shall be provided at suitable intervals if weather conditions warrant such provision.

*Note: Mist stations may also be arranged, when considered appropriate under certain organisational and/or climatic conditions.*

- 103 For all events longer than 10km, refreshment stations shall be provided every lap. In addition, water only drinking / sponging stations shall be placed approximately midway between the refreshment stations or more frequently if weather conditions warrant such provision.

- 104 Refreshments, which may be provided by either the Organisers or the athlete, shall be placed at the stations so that they are easily accessible to, or may be put by authorised persons into the hands of, the athletes. Refreshments provided by the athletes shall be kept under the supervision of officials designated by the Organisers from the moment that the refreshments are delivered by the athletes or their

representatives. Those officials shall ensure that the refreshments are not altered or tampered with in any way.

105 Authorised persons may not enter the course nor obstruct any athlete. They may hand the refreshment to the athlete either from behind, or from a position no more than one metre to the side, but not in front, of the table.

106 In competitions held under paragraphs 1.1, 1.2, 1.3 and 1.6 of the International Competition definition, a maximum of two officials per Member may be stationed at any one time behind the table. No official or authorised person shall, under any circumstances, move beside an athlete while they are taking refreshment or water.

*Note: For an event in which a Member may be represented by more than three athletes, the Technical Regulations may allow additional officials at the refreshment tables.*

107 An athlete may, at any time, carry water or refreshment by hand or attached to their body provided it was carried from the start or collected or received at an official station.

108 An athlete who receives or collects refreshment or water from a place other than the official stations, except where provided for medical reasons from or under the direction of race officials, or takes the refreshment of another athlete, should, for a first such offence, be warned by the Referee normally by showing a yellow card. For a second offence, the Referee shall disqualify the athlete, normally by showing a red card. The athlete shall then immediately leave the course.

*Note: An athlete may receive from or pass to another athlete refreshment, water or sponges provided it was carried from the start or collected or received at an official station. However, any continuous support from an athlete to one or more others in such a way may be regarded as unfair assistance and warnings and/or disqualifications as outlined above may be applied.*

Generally, where it is logical and in accordance with practice, there is uniformity of the provisions within Rules 54, 55 and 56 of the Technical Rules pertaining to outside events. It should be noted however that Rule 54.10.5 of the Technical Rules is intentionally different from Rule 55.8.5 of the Technical Rules in that in walking events, the team officials are not permitted in front of the tables.

## **ROAD COURSES**

11. Road Courses, as follows:
  - 11.1 The circuit shall be no shorter than 1 km and no longer than 2km. For events that start and finish in the stadium, the circuit should be located as close as possible to the stadium.
  - 11.2 Road courses shall be measured in accordance with Rule 55.3 of the Technical Rules.

### **RULE T54 (230) S 2 UKA SUPPLEMENT JUDGING**

Road Races may be promoted on open roads in the form of either a lap longer than 2km or a point-to-point race. In such cases Competition Providers must comply with all required safety conditions and conduct and work to appropriate risk assessments that comply with licensing conditions for events on the road.

## **RACE CONDUCT**

12. An athlete may leave the marked course with the permission and under the supervision of an official, provided that by going off course they do not shorten the distance to be covered.
13. If the Referee is satisfied on the report of a Judge or Umpire or otherwise that an athlete has left the marked course thereby shortening the distance to be covered, they shall be disqualified.

## SECTION VII – ROAD RACES

### RULE 55 ROAD RACES

#### DISTANCES

1. The standard distances shall be: 5km, 10km, 15km, 20km, Half-Marathon, 25km, 30km, Marathon (42.195km), 100km and Road Relay.

*Note: It is recommended that the Road Relay race be run over the Marathon distance, ideally over a 5km loop course, with stages of 5km, 10km, 5km, 10km, 5km, 7.195km. For an U20 Road Relay, the recommended distance is a Half-Marathon with stages of 5km, 5km, 5km, 6.098km.*

#### COURSE

2. The races shall be run on made-up roads. However, when traffic or similar circumstances make it unsuitable, the course, duly marked, may be on a bicycle path or footpath alongside the road, but not on soft ground such as grass verges or the like. The start and finish may be within an athletic Field of Play.

*Note (i): It is recommended that, for Road Races staged over standard distances, the start and finish points, measured along a theoretical straight line between them should not be further apart than 50% of the race distance. For approval of Records, see Rule 32.21.2 of the Competition Rules.*

*Note (ii): It is acceptable for the start, finish and other segments of the race to be conducted on grass or other non-paved surfaces. These segments shall be kept to a minimum.*

3. The course shall be measured along the shortest possible route that an athlete could follow within the section of the road permitted for use in the race.

In all competitions under paragraphs 1.1 and, where possible, 1.2, 1.3 and 1.6 of the International Competition definition, the measurement line should be marked along the course in a distinctive colour that cannot be mistaken for other markings.

The length of the course shall not be less than the official distance for the event. In competitions under paragraphs 1.1, 1.2, 1.3 and 1.6 of the International Competition definition, the uncertainty in the

measurement shall not exceed 0.1% (i.e. 42m for the Marathon) and the length of the course should have been certified in advance by a World Athletics approved course measurer.

*Note (i): For measurement, the "Calibrated Bicycle Method" shall be used.*

*Note (ii): To prevent a course from being found to be shorter than the official race distance on future re-measurement, it is recommended that a "short course prevention factor" be built in when laying out the course. For bicycle measurements this factor should be 0.1% which means that each km on the course will have a "measured length" of 1001m.*

*Note (iii): If it is intended that parts of the course on race day will be defined by the use of non-permanent equipment such as cones, barricades, etc. their positioning shall be decided not later than the time of the measurement and the documentation of such decisions shall be included in the measurement report.*

*Note (iv): It is recommended that for Road Races staged over standard distances, the overall decrease in elevation between the start and finish should not exceed 1:1000, i.e. 1m per km (0.1%). For approval of Records, see Rule 32.21.3 of the Competition Rules.*

*Note (v): A course measurement certificate is valid for 5 years, after which the course shall be re-measured even when there are no obvious changes to it.*

*NOTE: A UK Course Measurement Certificate is valid for 10 years.*

4. The distance in kilometres on the route shall be displayed to all athletes.
5. For Road Relays, lines 50mm wide shall be drawn across the course to mark the start of each stage distance (scratch line). Similar lines shall be drawn 10m before and 10m after the scratch line to denote the takeover zone. All takeover procedures, which, unless otherwise specified by the organisers, shall comprise a physical contact between the incoming and outgoing athletes, shall be completed within this zone.

**RULE T55 (240) S 1 UKA SUPPLEMENT  
COURSE**

- (1) The responsibility for providing a suitable course rests with the Competition Provider who must:
  - (i) take account of any advice given by the Local Authority Safety Advisory Group or equivalent, local Police Force, Highways Authority, Regional Licensing Panel and the UKA Course Measurer before publishing details of the course.
  - (ii) adequately signpost the course.
  - (iii) appoint marshals to direct runners throughout, particularly at intricate parts of the course and at road junctions.
- (2) Races shall be run on tarmac, concrete or paved surfaces. When traffic or similar circumstances make it unsuitable the course, duly marked, may be on a bicycle path or on a footpath, but should not be on soft ground such as verges or the like. Measuring a road surface can include a limited section off-road in length where needed. The agreed definition of a road course is determined from time to time by runbritain and the Association of UK Course Measurers.
- (3) A course that includes a railway level crossing will only be deemed safe and a licence issued where a written undertaking has been obtained from the Railway Track Authority that no train will use the line for the duration of the race.
- (4) The start and finish area may be in an enclosed ground or athletics arena. The start and finish areas should be traffic free.
- (5) If a race is advertised as being of a particular distance, then the correctness of that distance must be verified by a UKA qualified and registered and graded Course Measurer, accredited by, and using a measurement method approved by, the UK Association of Course Measurers.
  - (i) The course must be measured along the ideal line of running. i.e. the shortest possible route, in the section of the road permitted for runners, using a bicycle fitted with a Jones Counter and calibrated to World Athletics standards.
  - (ii) The measured distance must not be less than the advertised distance of the race, nor should it exceed the advertised distance by more than 0.2%.
- (6) All runners must follow the course as designed and follow the

normal rules of the road except where otherwise instructed by representatives of the Local Police or Local Authority or other authorised persons.

- (7) Where any part of a road used for a race is open to traffic at the same time as the competition is in progress, a runner must remain on the left hand side of the road (unless directed otherwise by the Police or a race official or other authorised persons).
- (8) The Race Referee has the power to disqualify any runner who does not follow the correct course or obey the instructions of a race official after consultation with the Competition Provider.

## **START**

6. The races shall be started by the firing of a gun, cannon, air horn or like device. The commands for races longer than 400m shall be used (Rule 16.2.2 of the Technical Rules). In races which include a large number of athletes, five-minute, three-minute and one-minute warnings before the start of the race should be given. On the command “On your marks”, the athletes shall assemble on the start line in the manner determined by the organisers. The Starter shall ensure that no athlete has their foot (or any part of their body) touching the start line or the ground in front of it, and shall then start the race.

As for middle and long distance Track Events, it is emphasised for events held outside the stadium that Starters and Referees should avoid being over-zealous in the application of the false start rules to such events. Recalling starts in road races and other outside events can be difficult, and in large fields impractical, in any case. However, where there is a clear and wilful breach, the Referee should not hesitate to consider appropriate action in respect of an individual either during or after the race. However, in major events, where the start mechanism malfunctions, and it is clear or possible that the timing system may not have started a recall where practical might be the best option.

## **SAFETY**

7. Organisers of Road Races shall ensure the safety of athletes and officials. In competitions held under paragraphs 1.1, 1.2, 1.3 and 1.6 of the International Competition definition, the Organisers shall

ensure that the roads used for the competition are closed to motorised traffic in all directions.

## **DRINKING / SPONGING AND REFRESHMENT STATIONS**

### **8. Drinking/Sponging and Refreshment Stations**

8.1 Water and other suitable refreshments shall be available at the start and finish of all races.

8.2 For all events, water shall be available at suitable intervals of approximately 5km. For events longer than 10km, refreshments other than water may be made available at these points.

*Note (i): Where conditions warrant, taking into account the nature of the event, the weather conditions and the state of fitness of the majority of the competitors, water and/or refreshments may be placed at more regular intervals along the route.*

*Note (ii): Mist stations may also be arranged, when considered appropriate under certain organisational and/or climatic conditions.*

8.3 Refreshments may include drinks, energy supplements, foodstuffs or any other item other than water. The Organisers will determine which refreshments it will provide based on prevailing conditions.

8.4 Refreshments will normally be provided by the Organisers but it may permit athletes to provide their own, in which case the athlete shall nominate at which stations they shall be made available to them. Refreshments provided by the athletes shall be kept under the supervision of officials designated by the Organisers from the time that the refreshments are lodged by the athletes or their representatives. Those officials shall ensure that the refreshments are not altered or tampered with in any way.

8.5 The Organisers shall delineate, by barriers, tables or markings on the ground, the area from which refreshments can be received or collected. It should not be directly in the line of the measured route. Refreshments shall be placed so



that they are easily accessible to, or may be put by authorised persons into the hands of, the athletes. Such persons shall remain inside the designated area and not enter the course nor obstruct any athlete. No official or authorised person shall, under any circumstances, move beside an athlete while they are taking refreshment or water.

- 8.6 In competitions held under paragraphs 1.1, 1.2, 1.3 and 1.6 of the International Competition definition, a maximum of two officials per Member may be stationed at any one time behind the area designated for them.

*Note: For an event in which a Member may be represented by more than three athletes, the Technical Regulations may allow additional officials at the refreshment tables.*

- 8.7 An athlete may, at any time, carry water or refreshment by hand or attached to their body provided it was carried from the start or collected or received at an official station.

- 8.8 An athlete who receives or collects refreshment or water from a place other than the official stations, except where provided for medical reasons from or under the direction of race officials, or takes the refreshment of another athlete, should, for a first such offence, be warned by the Referee normally by showing a yellow card. For a second offence, the Referee shall disqualify the athlete, normally by showing a red card. The athlete shall then immediately leave the course.

*Note: An athlete may receive from or pass to another athlete refreshment, water or sponges provided it was carried from the start or collected or received at an official station. However, any continuous support from an athlete to one or more others in such a way may be regarded as unfair assistance and warnings and/or disqualifications as outlined above may be applied.*

## **RULE T55 (240) S 2 UKA SUPPLEMENT REFRESHMENTS**

- (1) In full Marathons and longer races, Competition Providers must supply drinks to cater for the entire field at least every 5km throughout the race.
- (2) In races of 10km and above Competition Providers must supply drinks at intervals of not greater than 5km.
- (3) In races of less than 10km, drinks may be provided by the Competition Provider.
- (4) A Competition Provider must provide additional drink stations on the advice of the Race Medical Officer.
- (5) A Competition Provider should provide drinks for the entire field at the finish.

### **RACE CONDUCT**

9. An athlete may leave the marked course with the permission and under the supervision of an official, provided that by going off course they do not shorten the distance to be covered.
10. If the Referee is satisfied on the report of a Judge or Umpire or otherwise that an athlete has left the marked course thereby shortening the distance to be covered, they shall be disqualified.
11. Umpires should be placed at regular intervals and at each key point. Other umpires should move along the course during the race.

It is acknowledged that following the practice of first giving a warning when applying relevant aspects of Rule 55 of the Technical Rules and where applicable Rule 6.2 and 6.3 of the Technical Rules will create difficulties in implementation but where the opportunity arises, the Referee should do so. It is suggested that one option might be that course or refreshment station umpires be designated as assistant Referees and that they be in communication with the Referee and each other to ensure the effective co-ordination of warnings and disqualifications. But there remains the possibility as per the Note to Rule 6.2 of the Technical Rules that in some circumstances, disqualification can, and should, occur without a warning being given.

When a Transponder Timing System is not in use, or where an additional back-up recording system is desired, it is recommended that a funnel

system such as that described for Cross Country Races in the commentary on Rule 56 of the Technical Rules be used.

### **RULE T55 (240) S 3 UKA SUPPLEMENT RACE CLASSIFICATION**

- (1) An open road race is one which is open to all eligible runners subject to the restrictions on age and distance as defined in Rule 141.
- (2) A closed road race is one open only to runners in a particular Service, occupation, business house or educational establishment.
- (3) An open team road race is open to all Clubs affiliated to a National Association. Athletes must be registered in the current year with their National Association in order to compete as a First Claim athlete in Open Team Competition.
- (4) A closed team road race is confined to Clubs affiliated to UKA or other recognised Governing Body of athletics, within a particular category, e.g. Services, trade, occupation, business house, educational establishment.

*NOTE: Team races may be included by Competition Providers within any race subject to the above classifications.*

- (5) Competition Providers must declare in advance which team awards are included within the race and the manner in which they will be decided. Unless different details for a team competition are given by the Competition Providers any league competition held will be an open club team competition held with eligibility on the basis of (3) above.
- (6) Events for Masters shall be confined to athletes who are at least 35 years of age on the day of competition.

### **RULE T55 (240) S 4 UKA SUPPLEMENT RELAYS**

Where the number of stages in the relay exceeds eight, the number of entries will be restricted to three times the number of runners entitled to compete per team, or 36, whichever is the greater.

**NOTE:** World Athletics T55.1 relating to Relays will not apply.

### **RULE T55 (240) S 5 UKA SUPPLEMENT HEADPHONES**

The wearing of headphones, or similar devices, (other than those medically prescribed), is not permitted in races on any single carriageway road that is not wholly closed to traffic. This restriction does not apply to races held on dual carriageways provided that there are clear, structured separations between the separate carriageways. Competition Providers of races held entirely on roads closed to traffic may apply this condition where appropriate to local circumstances. Headphones that work by conducting sound through bones and do not sit in the ears are acceptable but a Competition provider may determine that they cannot be used in their race.

### **RULE T55 (240) S 6 UKA SUPPLEMENT- ASSISTANCE**

Runners must not be accompanied by a personally owned or controlled dog in the race.

*NOTE: Entries may be accepted from runners with medical assistance dogs, subject to them being correctly registered and identifiable as such; and subject to approval by the Race Director.*

### **RULE T55 (240) S 6 UKA SUPPLEMENT WHEELCHAIRS and BUGGIES**

- (1) The pushing of persons in any device is not permitted in any race held under UKA Rules of Competition (including but not limited to wheelchair, buggy, pushchair, stroller or similar).
- (2) The participation of wheelchair athletes on road courses open to traffic is not permitted in any UKA Licensed Race.
- (3) The participation of wheelchair athletes on road courses closed to traffic is permitted in UKA Licensed Races subject to Risk Assessment (see Risk Assessment Appendix).
- (4) The carrying of a child by any participant is not permitted in any race held under UKA Rules of Competition.

Notes:

*(i) Guidance on these issues can be found in Appendix 4: Endurance Running.*

*(ii) For the avoidance of doubt participation using hand-cranked or electric chairs is not permitted in any UKA Licensed Race held under UKA Rules of Competition.*

*(iii) A Competition Provider may, after due consideration within the Risk Assessment process, determine that a pushed wheelchair may be accommodated toward the rear of the event, on condition that the event is held on roads closed to traffic, meets runbritain Licence Standards and the participant is not attempting to compete against others.*

## SECTION VIII – CROSS-COUNTRY, MOUNTAIN AND TRAIL RACES

There are extreme variations in conditions in which Cross Country Running, Mountain Running and Trail Running are practised throughout the world and it is difficult to legislate international standardisation of these events. It must be accepted that the difference between very successful and unsuccessful events often lies in the natural characteristics of the venue and the abilities of the course designer. The following Rules are intended as a guide and incentive to assist Members to develop Cross Country Running, Mountain Running and Trail Running.

### **RULE 56 CROSS COUNTRY RACES**

#### **DISTANCES**

1. Distances at World Athletics Cross Country Championships should be approximately:

Men:	10km	Women:	10km
U20 Men:	8km	U20 Women:	6km

The distances recommended for U18 competitions should be approximately:

U18 Men:	6km	U18 Women	4km
----------	-----	-----------	-----

It is recommended that similar distances be used for other International and National competitions.

#### **COURSE**

2. Cross Country Course rules, as follows:
  - 2.1 The course must be designed on an open or woodland area, covered as far as possible by grass, with natural obstacles, which can be used by the course designer to build a challenging and interesting race course.
  - 2.2 The area must be wide enough to accommodate not only the course but also all the necessary facilities.
3. For Championships and international events and, wherever possible, for other competitions:
  - 3.1 A loop course must be designed, with the loop measuring between 1500m and 2000m. If necessary, a small loop can be added in order to adjust the distances to the required overall

distances of the various events, in which case the small loop must be run in the early stages of the event. It is recommended that each long loop should have a total ascent of at least 10m.

### **RULE T56 (250) S 1 UKA SUPPLEMENT LAP LENGTH**

The length of the lap in UK Cross Country Races should be between 1500m and 5000m.

- 3.2 Existing natural obstacles shall be used if possible. However, very high obstacles should be avoided, as should deep ditches, dangerous ascents / descents, thick undergrowth and, in general, any obstacle which would constitute a difficulty beyond the aim of the competition. It is preferable that artificial obstacles should not be used but if such use is unavoidable, they should be made to simulate natural obstacles met within open country. In races where there are large numbers of athletes, narrow gaps or other hindrances which would deny the athletes an unhampered run shall be avoided for the first 300m.
- 3.3 The crossing of roads or any kind of macadamised surfaces shall be avoided or at least kept to a minimum. When it is impossible to avoid such conditions in one or two areas of the course, the areas must be covered by grass, earth or mats.
- 3.4 Apart from the start and finish areas, the course must not contain any other long straight. A "natural", undulating course with smooth curves and short straights, is the most suitable.
4. Course markings, as follows:
- 4.1 The course shall be clearly marked with tape on both sides. It is recommended that all along one side of the course a 1m wide corridor, heavily fenced from the outside of the course, shall be installed for the use of organisation officials and media only (obligatory for Championship events). Crucial areas must be heavily fenced; in particular the start area

(including the Warm-up Area and the Call Room) and finish area (including any Mixed Zone). Only accredited people will be allowed access to these areas.

- 4.2 The general public should only be allowed to cross the course at well organised cross-over points, marshalled by stewards.
- 4.3 It is recommended that, apart from the start and finish areas, the course be a width of 5 metres, including the obstacle areas.
5. For Cross Country Relays, lines 50mm wide 20m apart shall be drawn across the course to denote the takeover zone. All takeover procedures, which, unless otherwise specified by the organisers, shall comprise a physical contact between the incoming and outgoing athletes, shall be completed within this zone.

### **START**

6. The races shall be started by the firing of a gun, cannon, air horn or like device. The commands for races longer than 400m shall be used (Rule 16.2.2 of the Technical Rules).

In races which include a large number of athletes, five-minute, three-minute and one-minute warnings should be given.

Wherever possible departure boxes should be provided for teams races with the members of each team to be lined up behind each other at the start of the race. In other races, the athletes shall be lined up in the manner determined by the organisers. On the command “On your marks”, the starter shall ensure that no athlete has their foot (or any part of their body) touching the start line or the ground in front of it, and shall then start the race.

### **RULE T56 (250) S 2 UKA SUPPLEMENT START**

The start should be signalled by the firing of a gun or other similar apparatus. An athlete crossing the starting line before the starting signal is given shall be liable to disqualification.

### **SAFETY**

7. Organisers of Cross-Country Races shall ensure the safety of athletes and officials.



## **DRINKING / SPONGING AND REFRESHMENT STATIONS**

8. Water and other suitable refreshments shall be available at the start and finish of all races. For all events, a drinking / sponging station shall be provided every lap, if weather conditions warrant such provision.

*Note: Where conditions warrant, taking into account the nature of the event, the weather conditions and the state of fitness of the majority of the competitors, water and sponges may be placed at more regular intervals along the route.*

## **RACE CONDUCT**

9. If the Referee is satisfied on the report of a Judge or Umpire or otherwise that an athlete has left the marked course thereby shortening the distance to be covered, they shall be disqualified.

### **RULE T56 (250) S 3 UKA SUPPLEMENT MISCELLANEOUS**

- (1) No athlete who is not qualified to compete shall join a Cross Country race. Athletes infringing this rule shall be liable to expulsion from any race under the jurisdiction of UKA and could render their club liable to disqualification.
- (2) Open Cross Country races must be advertised and decided under these Rules. Appropriate entry forms must be used for all individual entries. Inter-Club races for which no entry fee is charged are not considered Open Events.
- (3) The wearing of headphones, or similar devices, (other than those medically prescribed), is not permitted in Cross Country races. Athletes infringing this rule shall be liable to disqualification.

The finish area shall be wide enough to enable several runners to sprint side by side and long enough to separate them at the finish.

Unless a Transponder Timing System is being used together with a backup system (such as a video recording) to check finishing orders, finish lanes ("funnels") should be set up some 8 to 10 metres after the finish line with a maximum width of 0.70-0.80m. Once in the funnels, the athletes must not be able to overtake one another. The funnels should be 35-40m long into which the athletes will be directed as they cross the

finish line. At the end of each funnel, officials will note the athletes' numbers/names and if applicable recover their transponder timing chips. The funnels should have moveable ropes at the end at which the athletes enter, so that when one lane is full, the next rope can be drawn across behind the last athlete, to enable the next finisher to enter the new finish lane, and so on.

Judges and Timekeepers will additionally be placed on either side of the finish line and it is recommended that, in order to follow up any appeal relative to the finishing order, an official with video recording equipment (if possible with a timing clock in sight) shall be assigned and placed a few metres after the finish line in order to record the order in which the athletes cross the line.

## **RULE 57 MOUNTAIN AND TRAIL RACES**

### **PART ONE: GENERAL RULES**

#### **COURSE**

1. General Rules for the Course, as follows:
  - 1.1 The discipline of Mountain and Trail Running takes place on various types of natural terrain (sand, dirt roads, forest paths, single track footpaths, snow trails etc), and in various kinds of environment (mountains, forests, plains, deserts etc). Races take place mostly on off-road surfaces, however sections of paved surfaces (e.g. asphalt, concrete, macadam etc.) are acceptable as a way to reach or link the trails of the course but should be kept to a minimum. Preferably existing roads and trails should be used.
  - 1.2 For Mountain races only, some special exceptions do exist where races are held on a paved surface but are only acceptable when there are large elevation changes on the course.
  - 1.3 The course must be marked in such a way that nonnavigation skills will be required from the athletes.
  - 1.4 Trail races have no limits to distance or altitude gain or loss and the course must represent the logical discovery of a region.

- 1.5 Mountain races are traditionally divided into “uphill” and “up and down” races. The average altitude gain or loss can vary from approx. 50 – 250 metres per kilometre, and the distances up to 42.2km.

## **START**

- 2 Mountain and Trail races typically have mass starts. Runners can also start separated by gender or age-related categories.

## **SAFETY, ENVIRONMENT**

3. Organising Committees shall ensure the safety of athletes and officials. Specific conditions, such as high altitude, changing weather conditions and available infrastructure should be respected. The event organiser is responsible for taking care for the environment when planning the course, during and after the competition.

## **EQUIPMENT**

4. Mountain and Trail races do not imply the use of a particular technique, alpine or other, or the use of specific equipment, such as mountaineering equipment. The use of hiking poles could be permitted at the discretion of the Race organisation. The Race Organiser may recommend or impose mandatory equipment due to the conditions expected to be encountered during the race, which will allow the athlete to avoid a situation of distress or, in the case of an accident, to give the alert and wait in safety for the arrival of help.

## **RACE ORGANISATION**

5. The Organiser shall, prior to the race, publish specific regulations of the race including at minimum:
- 5.1 Details of the organiser responsible (name, contact details)
  - 5.2 Programme of the event
  - 5.3 Detailed information about the technical characteristics of the race: total distance, total ascent / descent, description of the main difficulties of the track
  - 5.4 A detailed map of the course
  - 5.5 A detailed profile of the course
  - 5.6 Course marking criteria
  - 5.7 Location of the control posts and medical / aid stations (if applicable)

- 5.8 Allowed, recommended or mandatory equipment (if applicable)
- 5.9 Safety rules to be followed
- 5.10 Penalties and disqualification rules
- 5.11 Time limit and cut-off barriers (if applicable)

## **PART TWO: INTERNATIONAL TECHNICAL RULES**

### **SCOPE OF APPLICATION**

- 6. While strongly recommended for all international championships, the application of the following technical rules is mandatory only in World Championships. For all Mountain and Trail Running events other than World Championships, the specific event rules and/or the national rules shall have precedence. If a Mountain and Trail Running competition is held under “International Technical Rules”, it must be specified in the event regulations. In all other cases, if a referee is appointed by a Member, an Area Association or the authority that oversees the competition, this person must ensure compliance with the general rules of Athletics but shall not enforce the following International Technical Rules.

#### **Start**

- 7. The commands for races longer than 400m shall be used (Rule 16.2.2 of the Technical Rules). In races which include a large number of athletes, five-minute, three-minute and one-minute warnings before the start of the race should be given. A 10s countdown to the start can also be given.

#### **Race conduct**

- 8. If the Referee is satisfied on the report of a judge, or Umpire, or otherwise, that an athlete:
  - 8.1 has left the marked course thereby shortening the distance to be covered;
  - 8.2 receives any form of assistance such as pacing, or refreshments outside of the official aid stations;
  - 8.3 does not comply to any of the specific race regulations;
 he shall be disqualified or get the penalty stated by the specific race regulations.

**RULE T57 (251) S 1 UKA SUPPLEMENT  
FELL AND HILL RACE CATEGORIES**

**(1) Domestic Race Categories**

A fell race is one run on fell, hill or mountain terrain and shall be categorised as follows:

**Category A**

- (i) Should average not less than 50m of climb per km.
- (ii) Should not have more than 20% of the race distance on road.
- (iii) Should be at least 1.5km in length.

**Category B**

- (i) Should average not less than 25m of climb per km.
- (ii) Should not have more than 30% of the race distance on road.

**Category C**

- (i) Should average not less than 20m of climb per km.
- (ii) Should not have more than 40% of the distance on road.
- (iii) Should contain some genuine fell terrain.

**(2) International Races**

International races affiliated to the World Mountain Running Association, and selection races organised by National Associations for International Races.

**(3) Race Length Categories**

- (i) A Category “L” (long) race is 20km or over.
- (ii) A Category “M” (medium) race is over 10km but less than 20km.
- (iii) A Category “S” (short) race is 10km or less.

Official UKA Fell, Hill and Mountain Races must be organised to comply with the Safety Requirements.

**Safety**

- (4)** The National Committees for Fell, Hill and Mountain Running are empowered to determine the rules and requirements for Fell, Hill and Mountain Running, including the Safety Rules for Competition Providers and runners, in consultation with UKA.

**Veteran age limits in races (Men and Women)**

- (5) For Fell, Hill and Mountain Running a Veteran is a competitor aged at least 40 years on the date of the competition.

**Specific Provisions for Trail Races**

9. Specific provisions for Trail Races, as follows:
- 9.1 Sections of paved surfaces shall not exceed 25% of the total course.
- 9.2 Races are classified by “km-effort”; the km-effort measure is the sum of the distance expressed in kilometres and a hundredth of the vertical gain expressed in meters, rounded to the nearest whole number (forexample, the km-effort of a race of 65km and 3500m ascent is:  $65 + 3500/100 = 100$ ); accordingly races will be classified as follows:
- | category | km-effort |
|----------|-----------|
| XXS      | 0 – 24    |
| XS       | 25 – 44   |
| S        | 45 – 74   |
| M        | 75 – 114  |
| L        | 115 – 154 |
| XL       | 155 – 209 |
| XXL      | 210 +     |
- 9.3 World Championships races shall be based on the Short (S) and the Long (L) categories:
- in the Short race the distance must be between 35km and 45km and the minimum vertical gain 1500m or more;
  - in the Long race the distance must be between 75km and 85km.
- 9.4 Competitions shall be based on the concept of self-sufficiency, meaning that the athletes will have to be autonomous between aid stations in terms of gear, communications, food and drink.
- 9.5 A survival blanket (140cm x 200cm minimum size), a whistle and a mobile phone are the minimum items the athletes have to carry at all times. However, the LOC may

impose additional mandatory items due to the conditions expected to be encountered during the race.

- 9.6 Aid stations at official competitions shall be sufficiently spaced out so as to respect the “principle of self-sufficiency”. The maximum total number of aid stations, excluding start and finish line, including water points, shall be no more than the km-effort points of the race divided by 15, rounded to the lower integer (example of a race with a km-effort of 58:  $58/15=3.86$ , which means no more than 3 aid stations, excluding start and finish, are allowed).

*Note (i): In a maximum of half of the above aid stations, rounded to the lower integer, food, drinks and personal assistance may be given (e.g. maximum total number of aid stations 3,  $3/2=1.5$ , maximum number of aid stations where food and personal assistance may be given is 1); at the remaining aid stations only drinks, but no food nor personal assistance, may be given.*

*Note (ii): aid stations layout, where personal assistance is allowed, shall be organized in a way that allows each country to have an individual table or allocated space, identified with the flag of the Country (or Territory) and where their official staff will give assistance to the athletes. Tables shall be organized by alphabetical order, and each team is allowed to have a maximum of 2 officials per table.*

*Note (iii): Assistance to the athletes may only be given at complete (food and drinks) aid stations as defined above.*

- 9.7 A finishing position resulting in a tie is permissible when clearly evident by the athletes’ intention.

## **SPECIFIC PROVISIONS FOR MOUNTAIN RACES**

10. Mountain races are classified as follows:
- 10.1 “Classic Uphill”
  - 10.2 “Classic Up and Down”
  - 10.3 “Vertical”,
  - 10.4 “Long Distance”
  - 10.5 Relays

11. In all categories other than Vertical, the average incline should be between 5% (or 50m per km) and 25% (or 250m per km). The most preferable average incline is approximately 10%-15% provided that the course remains runnable. These limits do not apply to the Vertical category, where the incline shall be not less than 25%.
12. World Championships races shall be based on the following categories and distances:
  - 12.1 “Classic Uphill”: 5km to 6km for Juniors (men and women); 10km to 12km for Seniors (men and women)
  - 12.2 “Classic Up and Down”: 5km to 6km for Juniors (men and women); 10km to 12km for Seniors (men and women)
  - 12.3 “Vertical”: it should have at least 1000m of positive vertical elevation and be measured in a certified manner to an accuracy of +/- 10m.
  - 12.4 “Long Distance”: the race distance should not exceed 42.2km and the nature of the course maybe mainly uphill or up and down. The total amount of ascent in the race should exceed 2000m. The men’s winning time should be between two and four hours and less than 20% of the distance should be paved surfaces.
  - 12.5 “Relays”: Any course or team combinations, included mixed gender / age group, are possible as long as they are defined and communicated in advance. Distance and elevation gain of each individual leg should respect the parameters of the “Classic” categories.
 

*Note (i): Classic Uphill and Classic Up and Down events traditionally alternate at each edition of the World Championships.*
13. Water and other suitable refreshments shall be available at the start and finish of all races. Additional drinking / sponging stations should be provided at suitable places along the course.

### **RULE T57 (252) S 1 UKA SUPPLEMENT TRAIL RACE CONDITIONS**

- (1) **Support Stations:** Unless stated otherwise in the advertisement and competitors’ brief, refreshment stations with drinks as a minimum



requirement should be not less than 10km apart and stocked with sufficient for the whole field. In warm weather extra stations with separation as little as 5km may be necessary.

- (2) **Along Roads:** UKA Rules for Road Running shall apply for parts of a course that are on roads, e.g. competitors must run on the left side of the road.

### **RULE T57 (252) S 2 UKA SUPPLEMENT TRAIL RACE COMPETITORS' RESPONSIBILITIES**

- (1) **Safety:** Competitors have a primary responsibility for their own safety.
- (2) **Course:** Follow the whole of the course as designed, unless they are leaving it for the purpose of retirement, in which event they may proceed to the nearest control station by a practically convenient route without trespassing. If they get lost or take a wrong turning competitors must return to the correct course, without trespassing, where they left it. They may be assisted in regaining the correct course.
- (3) **Other Rights of Way Users:** Unless the appropriate authority has closed the route to all other users, recognise they have equal rights to be on the path and be courteous.
- (4) **Behaviour at Obstacles & Narrow Paths:** Competitors should not jostle at stiles and other obstacles. Nor should they push past slower runners on narrow paths. The correct etiquette is for the overtaking runner to shout 'track' and the slower to step out of the way as soon as practical, standing still if necessary.
- (5) **Countryside Code:** In England and Wales 'The Countryside Code' must be obeyed, and in Scotland, The Scottish Access Code.
- (6) **Injured Competitors:** If they come across another competitor who is ill or hurt they **MUST** offer assistance.
- (7) **Voluntary Retirement:** If they wish to retire from the race they must report this to the nearest race official and to the finish, and then remove their number. If they become physically incapable of personally reporting, they should endeavour to get a message passed to an official.
- (8) **Compulsory Retirement:** Retire immediately if asked to do so by a race official.

**RULE T57 (252) S 3 UKA SUPPLEMENT TRAIL RACE  
ASSISTANCE**

- (1) **Assistance Whilst Running:** A competitor may only be accompanied by an attendant for all or part of a race when the rules for that particular race authorise this. Any limitations, such as when and where along the course this is allowed, must be clear in the rules of the race. Failure to comply may lead to disqualification of the competitor being helped.
- (2) **Supporters' Cars:** When the competitors' brief states that handlers and supporters following the race may park their cars only at designated places, failure to comply may lead to the disqualification of the competitor being supported.

## UKA GENERAL RULES

### G1 (20) Definition of Eligible Athlete

Athletes are eligible to compete if they agree to abide by the Rules and has not been declared ineligible.

### G 2 (21) Restriction of Competition to Eligible Athletes

#### RULE G2 (21) S 1 UKA SUPPLEMENT ELIGIBILITY TO COMPETE

#### Eligible Athletes

- (i) All competitions under the rules of UKA and Domestic Competitions held under World Athletics Rules are confined to eligible athletes as defined by these rules. All athletes in Age Groups covered by these Rules (Age Group Under 13 upwards) must be registered with their National Association and comply with their terms and conditions including payment.
- (ii) Should the Competitor not be registered they will be liable to disqualification and in such a case the competition shall be decided as if the ineligible competitor had not taken part. In an Inter-Club or Inter-Team competition that disqualification does not necessarily disqualify the Club concerned.
- (iii) Any protest in respect of the registration of an athlete must be made within 5 working days from the formal declaration of issuing the result of the competition.
- (iv) To aid the registration process:
  - (a) Athletes being registered with their National Association for the first time will have the provision of one week's grace to enable clubs to register their athletes retrospectively beyond the athletes' participation in a competition in which they have taken part.
  - (b) In addition Home Country Associations may give relaxation in part or whole to the above regulations, in their absolute authority, through the meeting licence

(normally for Track and Field events this would relate to Level 1 meetings but in exceptional circumstances also to Level 2 meetings).

- (v) Registration payment arrangements are at the discretion of the Home Countries.
- (vi) Unattached athletes and any Club member participating as an individual and not as a member of any Club Team, competing in Road Walking, Road Running, Fell, Hill and Mountain Running and Trail Running are excluded from these regulations.

*NOTE: Athletes registered with the National Committees for Fell, Hill and Mountain Running and Trail Running, are eligible to represent their club in team competition.*

### **RULE G2 (21) S 2 UKA SUPPLEMENT CLUBS**

- (1) Each Club and Competition Provider must be affiliated either to UKA for UK wide Competitions or to the National Association in whose geographical area of responsibility the Club's headquarters are located.
- (2) An affiliated Club or Competition Provider must supply to the Association to which it is affiliated, and to the UKA itself, such information as that body requires.
- (3) A Club must be properly constituted with a constitution which provides, inter alia, for its democratic management by means of a managing committee and the holding of an annual general meeting of all its members.
- (4) Athletics is organised within the following disciplines:
  - (i) Track and Field
  - (ii) Race Walking
  - (iii) Cross Country
  - (iv) Road Running
  - (v) Fell, Hill and Mountain Running
  - (vi) Trail Running

A club may only compete in Open Team Competitions if that Club is specifically affiliated for that discipline (not applicable to Trail Running).

WORLD ATHLETICS AND UKA GENERAL RULES 2020 EDITION  
**RULE G2 (21) S 3 UKA SUPPLEMENT**  
**CLUB MEMBERSHIP**

## Types

### (1) **First Claim Club Member**

- (i) The First Club joined by athletes will be known as their First Claim Club and such athletes are defined as a **First Claim member**. This status will remain in place until they give notice that they wish to terminate their membership of that Club. Such termination shall only be effective once all outstanding tangible assets of the former Club held by the athlete have been returned. If athletes wish to commence membership of a new First Claim Club then they must comply with the requirements set out in paragraphs (8) to (10) below.
- (ii) Once athletes have represented a Club in any Competition they are ineligible to compete for another Club in Open Team Competition immediately after resignation from that Club and until the transfer process to that Club has been completed in accordance with these Rules. For the avoidance of doubt, an athlete may compete as an individual during that period of ineligibility from team competition once their resignation and new membership have been accepted by both the respective Clubs.

(2) **Other Discipline First Claim Club Member:** Where a Club has not registered that Club for Open Team Competition in a particular discipline as set out in Rule G2 S2(4) above then that athlete may join another Club for First Claim Open Team Competition solely for the purpose of competition in that discipline. Should an athlete wish to register for this membership they must first complete the appropriate “Other Discipline Form” available from the National Associations and have that application confirmed by that Association.

(3) **Second Claim Club Member:** In addition to an athlete having a First Claim Club as defined in (1) above they are permitted to become a member of a Second Claim Club. Whilst this may be for social, coaching or other reasons that athlete may compete for that Club in competitions which specifically state in its rules that its competition is open to **Second Claim members**. Such an athlete is

hereafter defined as a Second Claim member. Any affiliated Club accepting a Second Claim or First Claim other member as a competing athlete must satisfy themselves that the athlete is already registered with their National Association.

- (4) **Higher Competition Club Member (HCA):** This category only applies to Senior and Under 20 Track and Field athletes who may apply for registration to compete for a ‘Higher Competition Club’ in **Senior Track and Field league competitions only**. The application, which shall be made to UKA, must be accompanied by the requisite fee which will be determined annually by the Board of UKA, but the fee shall only be payable in the first year of registration. The application will require approval and endorsement by UKA and once approved the athlete will be deemed to be a HCA member of that Club

All applications must be received by UKA on or before 1st March in the year of competition and will be effective for that calendar year only. Such application will only be accepted from athletes who, at the time of registration, are eligible to compete for their First Claim Club in open team competition. The registration will take effect from 1st April of the year in question. The registration must be renewed with the same or another Club for each and every year that the athlete wishes to benefit from such higher level competition.

Three tiers of league competition are recognised:

- (i) UK level (National Athletics League)
- (ii) Northern Irish; Scottish; Welsh; Midland; Northern and Southern Leagues
- (iii) Other Lower Level Leagues

Athletes may only join the ‘Higher Competition Club’ if their own First Claim club does not, in that season, compete in that league. Athletes may, at their discretion, decide whether to compete for their Higher Competition Club or their First Claim Club on any one day but not for both.

### **Process of becoming a member of a club, transferring clubs and resignation**

- (5) **Membership of a Club**, whether under (1), (2) or (3) above commences on the actual day of election by the Committee of that Club at a properly convened meeting.
- (6) **“Unattached”**: An athlete who is not a member of an affiliated Club shall be regarded as ‘unattached’. After one year of competition an athlete taking part in any event within disciplines listed in Rule G2 S2(4)(i) and (iii) must be a member of a Club affiliated to UKA and be registered with a National Association. Once an athlete has been registered with a National Association then it is not possible to return to “unattached” status. For the avoidance of doubt, this condition does not apply to athletes who participate solely in Road Walking, Road, Fell, Hill and Mountain or Trail events.
- (7) **Communication**: All communications between clubs or by athletes or clubs with UKA or National Associations may be either by letter or by electronic communication
- (8) **Transfer from one club to another**: Athletes desiring to change their First Claim Club must complete the form approved by UKA in every detail and submit it to the Home Country Eligibility Committee in which the headquarters of the Club they now wish to represent is located. This application must be accompanied by an administration fee of £10. (This fee is waived for athletes who are in the Under 13 or Under 15 age groups at the time of receipt of the application, although the necessary form needs to be completed and submitted to the relevant Eligibility Committee to register the change of first claim status)

An athlete who has taken part in any competition and / or has been registered at any time with a National Association must complete the change of club process as set out above. Former club members whose membership has lapsed by not paying a club fee, not being registered with a National Association or having not competed as a member of that club) for a period of 3 years from the date their membership lapsed may apply to join a different club on the basis that their previous membership has lapsed and the administration

fee will not be payable.

Provided that the applicant has not made a successful application for change of first claim status within a twelve month period and the completed application form and administration fee are received by the appropriate Eligibility Committee by the 10th day of the month, the change of first claim status, subject to the succeeding paragraph, will be operative from the 1st day of the following month. Applications received after the 10th of the month will not be reviewed until the following month and the change of first claim status will be operative from the first day of the month following acceptance.

Where an online eligibility transfer process is operated, the resignation is accepted unconditionally by the athlete's First Claim Club, no disputes or issues are identified and all interested parties agree, the athlete may be granted immediate clearance to compete as a First Claim Member of their new Club. Notification of clearance will be made to all affected Clubs. In all other cases the conditions expressed in the previous paragraph will apply.

Any athlete making a false declaration in support of such an application will be subject to at least a waiting period as outlined in (9) below and may be subject to more severe penalties.

- (9) If an athlete makes a second or subsequent application to change their first claim status within a twelve-month period then the process of applying is as outlined in G2 S8. If the application is in order and submitted by the 10th of the month then clearance will become operative on the first day of the fourth month following that acceptance.
- (10) An athlete wishing to claim partial or complete exemption from the imposition of the four-month waiting period may make application to the National Eligibility Committee in the manner identified in (8) above.
- (11) **Resignation from a Club:** A notice of resignation from a Club must be made in writing by the athlete, or by a parent/guardian of an athlete under the age of 16 and shall be determined by the Club Committee within one calendar month of receipt. In default of the appropriate National Eligibility committee shall determine that



resignation. Membership shall be deemed to have ceased on the actual date of submitting the resignation, (but see restriction identified in (1) above). Members wishing to join another Club following resignation must comply with the conditions within (8 - 10) above as applicable. After 28 days from ceasing to be a member of a Club or Association, having competed in disciplines listed in Rule G2 S2(4) (i), (ii) or (iii), athletes shall not be eligible to compete in Open Competition until they have again become members of an affiliated Club or Association.

- (12) Amalgamation or Absorption of a Club:** In the case of a Club amalgamated with, or absorbed by, another Club membership shall be regarded as continuous. If, however, members on receiving notice of the amalgamation or absorption of the Club, shall within 28 days notify in writing the Secretary of the Club, or other persons issuing such notice that they do not intend to continue in membership, such membership shall be regarded as having ceased on the date of amalgamation or absorption. The position of the athlete in regard to Open Team Competition shall be the same as if the original Club had been disbanded.
- (13) Membership arrangements where a Club is disbanded:** Athletes whose former Club has been officially disbanded may seek approval from the appropriate Eligibility Committee to represent another Club in Open Team Competition with effect from the first day of the following month.
- (14) Expulsion from Membership from an Affiliated Club:** The Management Committee of an affiliated Club shall have the power to expel any member whose membership is twelve months in arrears, provided that a month's notice in writing shall have been sent to the member's last known address giving information of the proposed action of the Committee.
- (15) Disputes between Athletes and their Clubs** relative to competition matters may be referred to the appropriate National Association Eligibility Committee for arbitration under its appeal procedure.
- (16) Expulsion from Membership by UKA:**
- ① In its consideration of matters referred to it by National Associations or Appeals received in accordance with Rule T8 S1, UKA may deem that the conduct of a member of an

Affiliated club in relation to any competition matter is sufficiently serious to demand that the affiliated club concerned expel that person from club membership in perpetuity or for such period of time that UKA may determine, including when that person:

- (a) has committed a serious criminal act
  - (b) is guilty of a serious breach of an anti-doping rule
  - (c) is guilty of a fundamental breach of UKA licensing conditions
- (ii) The above clause will also relate to any club member who is an Official, Coach or athlete support personnel considered to have offended under 16(i) above. Such expulsion to extend also to the removal of an Official or Coach UKA Licence.
- (iii) An affiliated Club which refuses to sanction the exclusion of such a person in turn renders itself liable to expulsion from membership of UKA, as does any other affiliated Club which allows the person concerned to become a member or to become associated with any of the Club's activities.

#### **RULE G2 (21) S 4 UKA SUPPLEMENT COMPETITION CONDITIONS**

- (1) **Birth qualification:** For the purpose of determining place of birth for a competition qualification this may be either at the location of actual birth or at the domicile of the mother at the time of birth, if different. In the event that the different locations are in different Counties or Districts then the athletes may make an irrevocable selection for which County or District they wish to be eligible. Once an athlete has made a decision as to their County or District of birth this may not be changed.
- (2) **Individual Open Competition:** An Open Competition is one which is open to all athletes who have registered with their National Association. The Association/ Competition Provider may define a particular geographical location and/or age group. Exemptions apply to Road, Hill and Fell and Trail races
- (3) **Open Team Competition:** Open Team Competitions are competitions open to all eligible Clubs affiliated for that discipline, including all Clubs in a particular Area, County, District and/or age group.

Only First Claim Members and Other Discipline First Claim Members of a Club may represent that Club in Open Team Competition unless the Competition Provider has stipulated that such competition is also open to Second Claim Members and Higher Competition Members as defined in 21 S3 and S4.

The Competition Providers of such competitions or races may make such qualifying conditions as they think fit, including the right to stipulate in Senior Track and Field League Competition that they shall be for First Claim and Higher Competition Club members only, but not at the exclusion of either. Notwithstanding the above, Senior Track and Field League Organisation rules may limit the number of Higher Competition Athletes allowed to compete per Club in any one fixture. This number must be at least two per Club. The rules of specific Leagues may permit a larger number to compete. Higher Competition Club members competing under these rules shall not have their points disallowed from their club's score because of their status as Higher Competition Club members unless the maximum allowed has been exceeded.

There is no restriction to the total number of Higher Competition Members that a club may have registered at any one time.

- (4) **Composite Teams:** Clubs may apply to become a Composite Team where from 2 to 5 Clubs wish to combine for specific competitions, usually Track and Field Leagues. Applications must be submitted to the relevant Competition Provider who may accept or reject such an application. Requests for the registration of a Composite Team must be received by the Competition Provider no later than 30th November of the preceding year. Applications approved by a Competition Provider, subject to compliance with application guidelines, will be notified to UKA. The relevant fee, which will be determined annually by the Board of UKA, is payable with the application. The Competition Strategy Group may agree, at their sole discretion, to vary these conditions.

*NOTE: Such an amalgamation of teams for competition purposes specifically does not require the Constitution of the Clubs concerned to be amalgamated.*

- (5) **Jurisdiction:** Every Competition Provider of an athletics meeting or competition under UKA rules, and every person tendering an

entry for such meeting or competitions shall be considered to have submitted to the jurisdiction of UKA on all questions which may arise concerning the application, construction, meaning or effect of the rules of UKA.

- (6) **Additional Rules & Conditions:** Any Competition Provider may apply additional rules and conditions to those required in UKA rules but must not relax any Rules.

*NOTE: A National Association may apply additional rules and conditions to competitions within their area of governance.*

- (7) **Health and Safety:** if the relevant Referee or Medical Officer of a Competition considers that the performance of any athlete may be injurious to their health and safety then that Referee can refuse to allow that athlete to start or continue to compete in a Competition at their sole discretion.

### **RULE G2 (21) S 5 UKA SUPPLEMENT FIRST CLAIM STATUS**

- (1) Where eligibility is not defined in the paragraphs 2 - 5 below, athletes who are registered with their National Association under Rule G2 S1 are eligible to represent a Club in Open Team Competition when they join their first Club as a first claim member.
- (2) **Where athletes are at school,** that school shall always have first claim on their services, irrespective of any other claim on them.
- (3) **When at University or Recognised Establishments of Higher Education**
- (i) Full time students at recognised establishments of Higher Education shall be eligible to compete in Open Team Competition for their College or University provided that their first claim club is not competing in that competition. In the case of a league where there is more than one division, this will be deemed to be the same competition for the purpose of this rule.
- (ii) An establishment of Higher Education can only invoke the provisions in (1) above if membership of its Club is solely restricted to students and staff of that establishment.
- (4) **Other Discipline Membership:** Where athletes' First Claim Clubs

do not affiliate to a particular discipline listed in Rule G2 S2(4) above, they are eligible to represent an Other First Claim Club in that discipline of athletics as defined in 3 above for which their First Claim Club does not affiliate, following approval from the appropriate National Eligibility Committee.

- (5) **Foreign Athletes:** Foreign Athletes: Under 20 and Senior athletes who are not eligible to compete for Great Britain and Northern Ireland under World Athletics Rules are only permitted to represent a Club in Open Team Competition as a first claim member if they:
- (i) satisfy the criteria for eligible residence set out below, and
  - (ii) have been registered as an eligible foreign athlete with UKA in the year of competition in accordance with the procedures then applied by UKA or have successfully applied under rule G2 S8 to the appropriate National Eligibility Committee for relaxation of or exemption from the above.

When applying for registration, the athlete must provide as much evidence as may reasonably be required in order to demonstrate their eligible residence and will be required to pay a registration fee in an amount from time to time determined by the Board of UKA. Application must be made to renew registration annually, but a fee shall only be payable in the first year of registration. Should an athlete change their World Athletics eligibility during the year from GB & NI to another Country (except as set out in the “Note” below) an application under this rule to register as an eligible foreign athlete is required and have that approved under this rule before they are eligible to resume Open Team Competition for their first claim club.

An athlete shall satisfy the criteria for eligible residence for the purposes of these Rules if they:

- (iii) have been continuously resident in the UK for a period of at least 4 weeks and
- (iv) their presence would not reasonably be regarded as temporary.

For these purposes, presence shall be regarded as temporary,

irrespective of the intended length of stay, if the primary purpose of that presence would reasonably be considered to be for any of the following: holidays, attending sports training or competition, visiting family members and work and educational visits, Provided that presence for the purposes of performing an employment contract or a formal course of education, in each case for a continuous period of at least 3 months, shall not be regarded as temporary.

Competition Providers may choose to apply more restrictive restrictions as allowed in G2 S4(6) Additional Rules & Conditions above.

When registered as an eligible Foreign Athlete, the registration may be revoked (with retrospective effect) if false information has been provided during the application process or the athlete's situation changes and the relevant Eligibility Committee deems that the athlete no longer satisfies the criteria for eligible residence.

*NOTE: Athletes possessing dual nationality of Great Britain and Northern Ireland and another country recognised by World Athletics will be regarded as eligible to seek to represent any Club under the jurisdiction of UKA unless they represent that other country in international competition when they will henceforth be regarded as an athlete governed by this Rule and will need to seek registration for subsequent seasons. Athletes born in Northern Ireland and resident within the United Kingdom are exempt from the requirement to register even if they have represented the Republic of Ireland in international competition.*

## **RULE G2 (21) S 6 UKA SUPPLEMENT COUNTY, DISTRICT AND AREA QUALIFICATIONS**

### **(1) English County Qualification**

- (i) County Championships are open to all eligible athletes possessing a County qualification.
- (ii) A County qualification may be acquired as follows:
  - (a) By birth (see also Rule G2 S4(1))
  - (b) By nine month's continuous bona fide residence in the

County immediately prior to the competition.

- (c) By service in a Unit of HM Forces stationed in the County for nine months immediately prior to the date of the competition. Temporary absence on duty shall not break a qualification acquired under this paragraph.

*NOTE: Membership of a Club affiliated to a County Association does not, of itself, provide an athlete with a County qualification unless at least one of (a) – (c) is above is satisfied.*

- (iii) Competitors who have qualified and competed, under (1)(ii)(b) or (c) above retain that qualification until they have acquired a residential qualification and competed in the Championship of another County or represented another County in an Inter-County Championship.
- (iv) A student at school, college or university does not acquire a residential qualification by residence in the County during term time only (See also (x) below)
- (v) An athlete who has competed in a County Championship (other than is allowed under (x) below) or represented a County in an Inter-County competition, may not compete in the Championships of, nor represent, another County in that Competition Year.
- (vi) County Inter-Team (including relay) Championships are open to:
  - (a) Any Club affiliated to the County Association, fulfilling the appropriate requirements of Rule G2 S2(4)
  - (b) Any Unit of HM Forces stationed in the County
  - (c) Any school, college or business house in the County

*NOTE: Every member of a team must hold a County qualification for that event as defined in (ii) above.*

- (vii) A County may at its discretion limit Team Championships to affiliated Clubs.
- (viii) Athletes whose first claim Club is not affiliated to the County Association may compete for their second claim Club in a County Inter-Team Championship if they possess the necessary County qualification.
- (ix) A Club may affiliate to more than one County.
- (x) A County may at its discretion relax the qualification in the

case of athletes in term-time residence at a school, college or university within its boundaries, but competition in any such events shall not be deemed to have established a County qualification for any inter-county competition. This discretion is not extended to include athletes of any age attending only as day students at the institution concerned.

- (xi) Where County boundaries are changed by law, affecting the place of birth or residence of an athlete, thereby moving it from County A to County B the following shall apply:
- (a) if athletes have already competed for County A, or in the Championships of County A, under (ii) above, they shall retain the existing birth or residential qualification unless notice is given in writing to the Honorary Secretary of County A that they wish henceforth to be qualified for County B.
  - (b) if athletes have not competed for County A or in the Championship of County A under (ii) above, the place of birth shall be deemed to have been in County B and any period of residence in County A to have been in County B.
- (xii) Competitors in an Inter-County Championship must possess a County qualification under (ii) above for the County they represent.

## **(2) English Area Championships and Representation**

- (i) Individual competition
- (a) An Area qualification to compete shall be acquired as follows:
    - By birth (See also Rule G2 S4(1))
    - By nine months' continuous bona fide residence within the Area boundary immediately prior to the date of competition.
    - By nine months' service in HM Forces stationed within the Area boundary immediately prior to the date of the competition.
  - (b) A student at school, college or university does not acquire a residential qualification by residence during term time alone. An Area, though, may, at its discretion, relax the



residential qualification in the case of Under 20 and younger athletes, and of Seniors in residence at college or university, but any competition shall not be deemed to have established an Area qualification.

- (c) An athlete may not compete in events within the same discipline in the Championships of more than one Area Association in any one nine-month period.

### **(3) Team Competition**

Area Competition: eligibility to compete shall be by first claim membership of a Club affiliated to that Area.

### **(4) Area Representation**

Athletes may compete for an Area provided they are eligible to compete in that Area's Championships as defined in 2(i) (a) above

### **(5) Scottish District Championships**

- (i) A District qualification shall be acquired as follows:
  - (a) By birth.
  - (b) By residence in the District.
  - (c) By first claim membership of an affiliated Club with its headquarters within the District boundary.
- (ii) Athletes may only compete at District Championships within one District in any six month period (commencing 1st April and 1st October)

### **(6) Welsh Regional Championships**

- (i) A Regional qualification may be acquired:
  - (a) By birth.
  - (b) By nine month's continuous bona fide residence in the Region
  - (c) By attendance at a school, college or university in the Region

NOTE: Students qualified under (c) above do not acquire qualification to participate in UK Inter-County competitions.

- (ii) An athlete who has competed in a Regional Championship or represented a Region in an inter-regional event may not compete in the championships of, nor represent another region, in the same year of competition.

**RULE G2 (21) S 7 UKA SUPPLEMENT  
HOME COUNTRY CHAMPIONSHIPS AND CLOSED  
CHAMPIONSHIP QUALIFICATIONS**

**(1) Home Country Closed Championship Qualifications**

Qualification to compete in a closed Home Country Championship shall be as identified in (2) below.

*NOTE 1: Athletes who have competed for one Home Country may only subsequently compete for another Home Country or at a closed Home Country Championship after a period of at least one year from their last representation for the previous Home Country, unless varied by agreement between both of the Home Countries involved.*

*NOTE 2: Athletes must be both a member of Club affiliated directly or indirectly to UKA and registered as an individual with a National Association in order to compete in national championships.*

**(2) Home Country Representation**

Qualification to compete for a Home Country in competitions within the United Kingdom shall be acquired:

- (i) by birth in the respective Home Country
- (ii) by birth of one or both parents in the respective Home Country
- (iii) by two year's continuous bona fide residence in the respective Home Country immediately prior to the date of the competition concerned.

*NOTE 1: Having qualified under (iii) above and competed for a Home Country at full Senior International level, such qualification may continue until the athlete qualifies and competes for another Home Country Association,*

*NOTE 2: A student at school, college or university does not thereby acquire a residential qualification by residence during term time alone.*

**RULE G2 (21) S 8 UKA SUPPLEMENT  
ELIGIBILITY AND EXEMPTION APPLICATIONS**

- (1) Each National Association shall appoint a Committee consisting of not fewer than five members which shall be called the Eligibility Committee. The Committee shall be responsible for deciding all matters relating to eligibility, including all first claims issues.
- (2) The Eligibility Committee shall have the powers:  
in any case where it considers that the general welfare of athletes or

athletics will be best served, to make an exception to the eligibility rules. They may grant exemption, either wholly or in part to these Rules.

For the avoidance of doubt issues arising in respect of Composite Teams, Foreign Athletes and Higher Competition Athletes will be dealt with by the UKA Eligibility Committee defined in (4) below.

Guidelines for considering claims for relaxation or exemption may include:

- (i) Where the change of Club is related to a genuine and significant change of residence. Such grounds are only considered if the application is made within twelve months of the change of residence provided that the new Club is nearer to the new residence. Or
  - (ii) Where the original Club is unable to provide the athlete with adequate competition or facilities, or
  - (iii) Where the Club from which the athlete has resigned gives its written support to the move. Such exemption, in whole or in part, may be granted on one occasion only, or
  - (iv) Where a specific welfare issue affects the ability of athletes to compete for their original Club.
  - (v) Where an application for registration as a Foreign Athlete is received at any time other than as defined in Rule G2 S5(5).
- (3) All applications for relaxation or exemption from the operation of any of the Rules must be accompanied by a fee of £10 to the relevant National Association, which may be refunded at the discretion of the Committee.
- (4) **Appeals:** In the event that an athlete or a Club is dissatisfied with the decision of the Eligibility Committee they shall write to the Chief Executive of UKA, together with a fee of £30 and complete documentary evidence for the application for exemption. The Chief Executive will immediately pass the papers to the UKA Eligibility Group (comprising Chair appointed by UKA, one member from each National Association Eligibility committee, and the members of the appeal panel together with ex-officio the leading member of UKA staff responsible for Eligibility within UKA and the leading member of England Athletics who acts as UKA's Agent in managing the eligibility processes on behalf of UKA). The Chair of the UKA Eligibility Group will convene the Appeal Panel comprising three members of the Group who are not members of the Clubs involved, who will consider and determine the Appeal within four weeks of receipt of the Appeal. The

decision of the panel will be final and binding. A refund of the application fee may be made at the discretion of UKA. No new evidence will be accepted by UKA that has not been submitted to the Association concerned [unless so agreed by the Appeal Panel]

**RULE G2 (21) S 9 UKA SUPPLEMENT  
OPEN TEAM COMPETITION**

- (1) Generally in any Open Relay Race Clubs shall not be allowed to enter more than three times the number entitled to compete. A Club entering more than one team in a race shall be allowed to select their teams from the Club entry for that event, but no athlete may compete for more than one team. Teams must be declared before the start of the race.
- (2) Ineligibility of a competitor in an Inter-Club or Inter-Team competition does not necessarily disqualify the Club concerned and in such a case the competition shall be decided as if the ineligible competitor had not taken part.
- (3) No athletes shall be allowed to compete in a team unless their names have been declared prior to the event. If it is impracticable to issue a programme a complete list of the entries should be provided for the Referee.
- (4) **Track & Field**
  - (i) In any Open Team Race Clubs shall not be allowed to enter more than twice the number entitled to compete.
  - (ii) A Club entering more than one team in a race shall be allowed to select their teams from the Club entry for that event.
  - (iii) Competition Providers must specify, prior to the event, whether Clubs are to declare their teams before the start of the race.
  - (iv) At the discretion of the Referee a team may be permitted to start fewer competitors than the minimum number required to score.
  - (v) Stations shall be drawn and the members of each team shall, if necessary, be lined up behind each other at the start of the race.
  - (vi) The team scoring the least number of points, according to the positions in which the members of the team finish whose positions are to count, shall be the winner; the positions of the non-scoring members of a team, whether it finishes all its

members or not, shall be scored in computing the totals of the other teams. In the event of a tie on points, the team whose last scoring member finishes nearest first place shall determine the result.

- (vii) Alternatively, team position may be decided on the aggregate time of the scoring members of the team, the team having the lowest aggregate being the winner. Time aggregates shall only be used if the Competition Provider has announced in advance that this method will be used.
- (viii) In the case of a tie between two or more individual competitors each shall score for the team a number of points obtained by dividing the total sum of their position numbers, reckoned as if they had, instead of being tied, finished regularly in a file, by the number of such competitors. (Thus, for instance, if two competitors finish tied for second place, each of them shall score 2 1/2 points).

#### **(5) Cross Country**

Unless otherwise specified by the Competition Provider, the team scoring the least number of points, according to the positions in which the members of the team finish whose positions are to count, shall be the winner; the positions of the non-scoring members of a team, whether it finishes all of its members or not, shall be scored in computing the totals of the other teams. In the event of a tie on points, the team whose last scoring member finishes nearest first place shall determine the result.

In cross country relay races where a team includes a runner who has already run a stage of the race, that team shall not, subject to the entry conditions of the race, be included in the official results.

#### **(6) Road Races**

- (i) Competition Providers must specify, prior to the event, whether Clubs are to declare their teams prior to the start of the race.
- (ii) Competition Providers may nominate a time before which all team declarations must be submitted.
- (iii) Team positions in road race team competitions may be decided by the total achieved by adding the times of all scoring members together, the team with the lowest aggregate time taking precedence. When transponders are used to record

times the gun to finish mat time should take priority in deciding team positions, however when wave starts are used then transponder times may be used. Alternatively, the competition may be decided according to the finishing positions of the scoring members of the team.

The team scoring the least number of points, according to the positions in which the members of the team finish whose positions are to count, shall be the winner; the positions of the non-scoring members of a team, whether it finishes all of its members or not, shall be scored in computing the totals of the other teams. In the event of a tie on points, the team whose last scoring member finishes nearest first place shall determine the result.

- (iv) All teams in a Road Relay must be declared before the start of the race and the stage order of runners specified in the manner laid down by the Competition Provider. No changes may be made in the declared order of running without the prior approval of the Race Referee and the Competition Provider.

**(7) Road Relays**

Where a team includes a runner who has already run a stage of the race that team shall not, subject to the entry conditions of the race, be included in the official results.

**(8) Fell, Hill and Mountain Running**

Fell, Hill and Mountain Running Runners may count in team races for their first claim Club only. This Club may be different from their first claim road, cross country or track Club but must comply with Rule G2 S3.

**G3 (23) Persons Subject to Declaration of Ineligibility**

4.1 Subject to Rule 4.2, any athlete, Athlete Support Personnel or other person:

4.1.1 who takes part in an athletics competition or event in which any of the competitors were, to their knowledge, suspended from participation or ineligible to compete under these Rules, or which takes place in a Country or Territory of a suspended Member. This does not apply to any athletics competition which is restricted to the Masters' age group (in accordance with Rule 3 of the Technical Rules);

- 4.1.2 who takes part in any athletics competition which is not authorised in accordance with Rule 1 of the Competition Rules;
  - 4.1.3 who contravenes the Requirements to Compete in International Competitions Rules or any Regulations made thereunder;
  - 4.1.4 who contravenes the Eligibility to Represent a Member Rules or any Regulations made thereunder;
  - 4.1.5 who contravenes the Payments to Athletes Rules or any Regulations made thereunder;
  - 4.1.6 who contravenes the Athletes' Representatives Rules or any Regulations made thereunder;
  - 4.1.7 who contravenes the Advertising and Displays during International Competitions Rules or any Regulations made thereunder;
  - 4.1.8 who commits a breach of any other Rule (other than as set out in Rule 2 of the Disputes and Disciplinary Proceedings Rules);
- may be declared ineligible under Rules 4.2 to 4.22 of these Rules.

### **RULE G3 (23) S 1 UKA SUPPLEMENT INELIGIBILITY TO COMPETE**

The following are ineligible to take part in Competition under UKA Rules: Any person who:

- (i) is not registered with their National Association and conformed with their requirements as set out in Rule G2 S1(1) above.
- (ii) is ineligible to compete in competitions under the jurisdiction of any National Governing Body of athletics affiliated to World Athletics.
- (iii) takes part in any athletics meeting which requires to be sanctioned but has not been permitted / licensed by UKA or other appropriate Association.
- (iv) has been declared ineligible to compete by World Athletics.
- (v) has committed any acts or made any statements either verbally or in writing or has been responsible for any breaches of the Rules, or other conduct which, in the opinion of a National Association is considered to be insulting, improper or likely to bring the sport and/or UKA into disrepute.
- (vi) Unless the period of ineligibility is stated in the relevant Rule or Regulation of World Athletics or UK Athletics, those

ineligible under this Rule shall be deemed ineligible for a period set down in guidelines produced by the Board of UKA, or, in the absence of such guidelines, for such period as the Board of UKA (for doping matters) or the National Association (for all non-doping matters) shall decide.

- (vii) If athletes compete whilst suspended or ineligible, the period of this ineligibility shall be deemed to recommence from the time they last competed as though no part of a period of suspension or ineligibility had been served.

**ANTI-DOPING and BETTING**  
**RULE G4 (30) S 1 UKA SUPPLEMENT**  
**ANTI-DOPING**

Doping by anyone under the jurisdiction of the UKA Anti-Doping rules, whether committed in or out of competition, is strictly forbidden and is an offence. The full UKA Anti-Doping Rules, including details of the various anti-doping rule offences and the sanctions, along with other relevant information about the UKA “Clean Athletics” programme, can be found at [www.uka.org.uk/cleanathletics/](http://www.uka.org.uk/cleanathletics/). The UKA Anti-Doping Rules, which may be amended from time to time, shall be deemed to form part of these Competition Rules as if set out in full in these Rules as so amended.

**RULE G5 (60) S 1 UKA SUPPLEMENT**  
**BETTING**

*NOTE: Please refer to the World Athletics Integrity code of conduct which can be found at <https://www.worldathletics.org/about-iaaf/documents/book-of-rules> for full information on processes to be adopted in the event of an investigation in the UK. All betting at the venue of an event is strictly prohibited.*

UKA has the jurisdiction to investigate any allegations of misconduct within the terms of this Rule in so far as they apply to competitions permitted or licensed by UKA or one of the National Associations and, if proven, may apply appropriate sanctions within the terms contained in UKA Supplements to these Rules.

Upon request by the UKA Anti-Corruption Officer or the UKA Chief Executive Officer, a person subject of the Code shall cooperate fully,



accurately and promptly with and shall provide all necessary assistance to the UKA Anti-Corruption Officer with respect to any matter pursuant to this regulation (including answering the questions of and furnishing the Anti-Corruption Officer with, all relevant and/or requested documentation and information).

### **RULE G6 (6) PAYMENTS TO ATHLETES**

Athletics is an open sport and, subject to the Rules and Regulations, athletes may be paid in cash or in kind in any way appropriate for appearing, participating or performing in any athletics competition or engaging in any other commercial activity related to their participation in Athletics.

### **RULE G7 (7) ATHLETES' REPRESENTATIVES**

1. Athletes may use the services of an Athletes' Representative to assist them in the negotiation of their athletics programme and in such other matters as they may agree. Alternatively, athletes may negotiate their own Athletics programmes.
2. Athletes in the World Athletics Top-30 List in a standard event as of the end of a calendar year shall not, during the following year, enter into or extend an agreement to use any person in respect of the above services who is not an Athletes' Representative.
3. Members, acting reasonably, shall be responsible for the authorisation and recognition of Athletes' Representatives. Each Member shall have jurisdiction over Athletes' Representatives acting on behalf of their athletes and over Athletes' Representatives acting within their Country or Territory or over Athletes' Representatives who are nationals of their Country.
4. To assist Members in this task, the Council shall publish Regulations governing Athletes' Representatives. The Athletes' Representative Regulations shall provide for mandatory requirements to be included in each Member's regulations governing Athletes' Representatives.
5. It is a condition of Membership that each Member includes a provision in its constitution that all agreements between an athlete and an Athletes' Representative shall comply with the Rules and the Athletes' Representative Regulations.

6. An Athletes' Representative shall have integrity and good reputation. If required to do so, he shall demonstrate sufficient education and knowledge for the activity of Athletes' Representative by successfully completing an examination established and organised in accordance with the Athletes' Representative Regulations.
7. Each Member shall annually provide to World Athletics a list of all Athletes' Representatives that it has authorised or recognised. World Athletics shall annually publish an official list of all Athletes' Representatives.
8. Any athlete or Athletes' Representative who does not comply with the Rules and Regulations, may be subject to sanctions in accordance with the Rules and Regulations.

### **RULE G7 (7) S 1 UKA SUPPLEMENT ATHLETES' REPRESENTATIVES**

An athlete's representative is any individual who advises or assists athletes in the planning, arranging and negotiation of their athletic programme.

- (1) UKA shall authorise, register and have jurisdiction over all Athletes' Representatives acting within its territory, under the terms of World Athletics Rule 7, together with any Regulations and Guidelines published by UKA. UKA will only authorise individuals to be Athletes' Representatives.
- (2) No athlete is permitted to use the services of any Athlete's Representative not authorised by UKA and any athlete who does so may be subject to sanctions in accordance with UKA and/or World Athletics Rules together with any Regulations made there under. Athlete's Representatives require authorisation from UKA when acting as an Athlete's Representative in relation to any athlete, whether or not the athlete concerned is subject to the jurisdiction of UKA or competing within the United Kingdom.
- (3) UKA shall establish such procedures as it thinks fit for the authorisation and regulation of Athlete's Representatives. UKA shall be empowered to withdraw, cancel or suspend the authorisation of any Athlete's Representative and all authorised Athlete's Representatives shall comply with such direction(s) that UKA may issue from time to time.

- (4) Athletes may use the services of any authorised Athlete's Representative with the prior consent of UKA but no such consent shall be granted and no Athlete's Representative shall receive authorisation unless a contract exists between the athlete and his/her Representative which contains the minimum terms set out in the Guidance Notes issued both by World Athletics and UKA referred to in paragraph Rule 7 S1(2) above.

### **RULE G8 (8) ADVERTISING AND DISPLAYS DURING INTERNATIONAL COMPETITIONS**

1. Advertising and displays of a promotional nature shall be permitted in all International Competitions as specified in Rule 1.2(c), provided such advertising and displays comply with the terms of this Rule and with any Regulations that may be passed hereunder.
2. The Council may pass Regulations from time to time giving detailed guidance as to the form advertising may take and the manner in which promotional or other material may be displayed at International Competitions conducted under these Rules. These Regulations shall adhere to at least the following principles:
  - 2.1 Only advertising of a commercial or charitable nature shall be allowed at competitions conducted under these Rules. No advertising which has as its objective the advancement of any political cause or the interests of any pressure group, whether domestic or international, shall be allowed.
  - 2.2 No advertising may appear which, in the opinion of World Athletics, is tasteless, distracting, offensive, defamatory or unsuitable bearing in mind the nature of the event. No advertising may appear which obscures, either partially or otherwise, the television camera's view of a competition. All advertising must comply with any applicable safety regulations.
  - 2.3 The advertising of tobacco products is prohibited. The advertising of alcohol products is prohibited, unless expressly permitted by the Council.
3. The Regulations under this Rule may be amended by the Council at any time.

**RULE G8 (8) S 1 UKA SUPPLEMENT  
ADVERTISING AND SPONSORSHIP**

See the UKA Supplements in Rule T5 for conditions applying to clothing, advertising and sponsorship.

## **RULE G9 (Appendix 1) UKA SUPPLEMENT ULTRA DISTANCE ROAD AND TRACK EVENTS**

The following rules include the use of transponder technology and are now recognised by UKA for the conduct of track and road events over 30km. Long distance track events must be conducted according to the Rules of World Athletics and UKA, which shall apply except where specifically modified within these Rules.

### **G9 ULTRA 1 RECORDS**

UKA authenticates track and road records and maintains lists of best performances as shown below in (i) to (iii). The categories maintained are: World Record/Best Performances for distances accepted by the World Athletics, United Kingdom (All Comers) Record/Best Performances and United Kingdom (National) Record/Best Performances for all categories. Any application for a Best Performance shall be sent to UKA and the UKA Ultra Running Advisory Group without undue delay, together with the supporting documents required. After the Record/Best Performance has been ratified by this group it will be included when the list of Best Performances and Records is next published.

Records will only be ratified if the performance has been achieved in a race that has been awarded an IAU label (licence).

Note: IAU (International Association of Ultrarunners) Labels confirm that race courses are measured to conform to World Athletics regulations, and races are recognised by their own National Athletics Federation

The distance/time periods for which records and/or best performances are recognised are the following:

- (i) 50km, 100km and 100 miles
- (ii) 1,000 miles, 6 hours and 12 hours
- (iii) 24 hours, 48 hours and 6 days.

### **G9 ULTRA 2 TRACK SPECIFICATION AND PACING**

Track races must be held outdoors on a 400 metre track (with raised border as identified in Rule 14 S1(1)) and in bona fide competition, i.e. more than one competitor and no pacing.

- (1) Pacing may be interpreted as taking place when a runner not officially entered in the competition, or a runner entered in the competition who does not start, or a runner who has dropped out of the competition, runs more than 200 metres with the record claimant. The Race Referee has discretion to decide whether the claimant has received unfair assistance.
- (2) The event must have been advertised beforehand and a programme must have been produced bearing the claimant's name.

### **G9 ULTRA 3**

#### **ROAD – SET DISTANCE/FIXED TIME**

Transponder timing may be employed as an alternative to manual timekeeping for road and track races. Ultra Rule 9 will apply and must be included in the event organisation in the case of a technical fault or loss of power with a transponder system.

#### **Transponder Timing**

- (1) The use of transponder timing systems is permitted provided that:
  - (i) the system requires no action by an athlete during the competition, at the finish or at any stage in the result processing.
  - (ii) the weight of the transponder and its housing carried on the athlete's uniform, race number or shoe is not significant.
  - (iii) none of the equipment used at the start, along the course or at the finish line constitutes a significant obstacle or barrier to the progress of the athlete.
- (2) At the finish the athletes shall still be placed in the order in which any part of their bodies (i.e. the torso as distinguished from head, neck, arms, hands, feet and legs) reaches the vertical plane of the nearer edge of the finish line. The Referee shall be final arbiter regarding the finishing order of the athletes.
- (3) In competitions where the Competition Provider chooses to use a transponder timing system, each competitor must wear the necessary equipment, as directed by the Competition Provider. Failure to wear the necessary equipment as issued may result in disqualification.

#### **Manual Timing**

- (4) In every long distance road race the lap times of every competitor must be taken and recorded on a lap scoring board.
- (5) Each competitor should have a lap scorer, though a skilled lap scorer

may record more than one competitor. A lap scorer may be replaced by another during the race. Lap scorers must sign the boards/sheets they have completed any part of.

- (6) A display clock should be placed at the finish of each lap so that the lap scorers and competitors may read the time. If this is not available, a Timekeeper must call out lap times of all competitors during the race.
  - (7) An additional record should be kept of the leader's lap times during the race.
  - (8) Any application for a Best Performance must be accompanied by the lap scoring board of the claimant and of the race leader.
- (These Rules do not apply to point-to-point races).

## **G9 ULTRA 4 TRACK – LAP TIMES – SET DISTANCE**

### **Transponder Timing**

- (1) The use of a transponder timing system is permitted for pre-set ultra-distance track events provided that:
  - (i) In competitions where the Competition Provider chooses to use a transponder timing system, each competitor must wear the necessary equipment, as directed by the Competition Provider. Failure to wear the necessary equipment as issued may result in disqualification.
  - (ii) the weight of the transponder and its housing carried on the athlete's uniform, race number or shoe is not significant.
  - (iii) none of the equipment used at the start, along the lap or at the finish line constitutes a significant obstacle or barrier to the progress of the athlete.
  - (iv) The lap times of every competitor must be recorded on a lap scoring board, visibly accessible LCD screen at track side and/or other lap scoring systems linked to the transponder process.
  - (v) A display clock should be placed at the finish of each lap so that competitors may read the elapsed time and distance.
  - (vi) At the finish the athletes shall still be placed in the order in which any part of their bodies (i.e. the torso as distinguished from head, neck, arms, hands, feet and legs) reaches the vertical plane of the nearer edge of the finish line. The Referee shall be

final arbiter regarding the finishing order of the athletes.

### **Manual timing**

- (2) In every long distance track race the lap times of every competitor must be taken and recorded on a lap scoring board.
- (3) Each competitor should have a lap scorer, though a skilled lap scorer may record more than one competitor. A lap scorer may be replaced by another during the race. Lap scorers must sign the boards/sheets they have completed any part of.
- (4) A display clock should be placed at the finish of each lap so that the lap scorers and competitors may read the time. If this is not available, a Timekeeper must call out lap times of all competitors during the race.
- (5) An additional record should be kept of the leader's lap times during the race.
- (6) To reduce the likelihood of human error, lap recorders must be in an elevated, tiered seating area sited directly opposite the lap start/finish line. This should give each one a clear unobstructed view of the line and the race clock.
- (7) Any application for a Best Performance must be accompanied by the lap scoring board of the claimant and of the race leader.

## **G9 ULTRA 5 FIXED TIME RACES**

- (1) Some long-distance road/track races are held over a fixed period of time (e.g. 24, 48 hours) rather than a fixed distance. In such races, a competitor need not necessarily be on the road/track at the end of the race, the winner being the competitor who covers the greatest distance during the period of the race.
- (2) On completion of the fixed time, a recorder/official is responsible for marking the exact spot of each runner on the lap, which is to be taken at the rear of the runner's foot. The distance is measured by steel tape from the nearest convenient marker. All distances are to be rounded down-wards to the nearest metre.

(Rule G9 4(1) (i) to (iv) also applies to these events)



## **G9 ULTRA 6 MULTI-DAY RACES**

In some multi-day track races and Ultra-distance track races the runners reverse direction every 3–4 hours. This has been found to reduce the risk of injury. When the signal is given, each runner should complete the lap currently in progress and then reverse direction. During this procedure, runners who have not yet reversed have priority in the inside lane.

## **G9 ULTRA 7 GENERAL CONDITIONS TRACK – SET DISTANCE / FIXED TIME**

Minor departures are allowed from normal World Athletics and UKA Rules in view of the special nature of long distance track races.

- (1) The maximum number of starters for any event over 30 miles should not exceed 60 in number.
- (2) Race numbers must be worn by runners, above waist height to the front and rear and clearly visible, on all clothing, at all times for the duration of any type of event.
- (3) Each runner/lap recorder should be made known to each other prior to the event start. They should agree two signals: one to acknowledge to each other at the end of a lap that the lap has been completed/recorded and the other to indicate to the recorder that the runner's next lap time will be extended because they will be leaving the track for a short time. This extended lap should be indicated on the scoring board/sheet by the lap recorder (see also (6) below).
- (4) There are no restrictions on the supply of refreshments during the race.
- (5) A runner may be accompanied by an attendant for such purposes as refreshments and changes of kit. The attendant is not permitted to render any direct assistance to the runner's progress (this includes pacing: see G9 2(2)), and must not interfere with other competitors or officials.
- (6) A competitor may leave the track and return to the same place on the track provided, in the opinion of the Referee, the time off the track is not excessive.
- (7) A competitor may claim a Record/Best Performance at a distance less than the advertised distance of the race.

- (8) Women may compete in the same race as men, and female performances shall be eligible for ratification as Records/Best Performances.
- (9) Lapped runners are not eliminated from the race.
- (10) The runner with the greatest distance achieved during the fixed time does not have to be on the track when the fixed time ends.

### **G9 ULTRA 8 MANUAL TIMEKEEPING**

- (1) There should be three UKA qualified Timekeepers, one of whom is appointed Chief Timekeeper, all using timers of a kind approved by UKA.
- (2) The Timekeepers must time the race independently, and exhibit their times to the Chief Timekeeper. Each of the three times must be entered on the record application form. The Chief Timekeeper shall return the time of the race, if two timers agree and the other disagrees, as the time of the two which agree. If all three timers disagree, the middle of the three times shall be recorded as the official time. If for any reason only two timers record the time, the longer of the two shall be taken as the official time.
- (3) All times shall be rounded up to the next whole second.
- (4) In longer races, where the guaranteed accuracy of watches is greater than +/-0.5 seconds over the period of the race, the BBC radio signal received by an AM or FM receiver should be used to judge if any correction factor is required.

**APPENDIX 2 & 3**  
**TECHNICAL OFFICIALS PATHWAY**  
**(Track & Field)**

and

**APPOINTMENT OF, DUTIES OF & SELECTION OF**  
**OFFICIALS**

Located at <https://www.uka.org.uk/competitions/rules/>  
from 1<sup>st</sup> April 2020

## APPENDIX 4

### ENDURANCE RUNNING

#### Endurance Disciplines and Definitions

UKA and the four National Associations (England Athletics, Athletics Northern Ireland, Scottish Athletics and Welsh Athletics) regulate competition, either directly or indirectly, for the disciplines of Road Running (Rule T55), Cross Country (Rule T56), Race Walking (Rule T54), Fell and Hill Running (Rule T57) and Trail Running (Rule T57). Mountain Running events, under World Mountain Running Association (WMRA) Rules, are promoted in the UK (see the section below where we define the different disciplines).

The term “multi-terrain race” is in common usage but these events should be classified within Road Running for licensing standards.

Ultra races are held at distances exceeding the Marathon. Races may be hosted on road, trail or track and may be based on either distance or time. Ultra races shall be held under the UKA Rules for Competition for the endurance discipline that most closely reflects the nature of the event.

Fun Runs and parkruns are further additions to the accepted disciplines and definitions are offered below.

#### Road Running

Road Races shall be run on tarmac, concrete or paved surfaces. When traffic or similar circumstances make it unsuitable the course, duly marked, may be on a bicycle path or footpath alongside the road, but should not be on soft ground such as verges or the like. (UKA Rule T55 S1(2))

Guidance provided by the Association of UK Course Measurement is available at: <http://www.coursemeasurement.org.uk/>

A firm off-road surface such as smooth grass or dirt can be measured with an accuracy of about 1% using a calibration done on a road surface. The maximum amount of such off-road surface which could be used and still retain the overall accuracy of measurement of a road race:

- Up to 10kms: 10% off-road allowed (on “smooth grass or dirt”).
- Excess amount over 10kms: 5% off-road allowed

For a number of popular race distances this gives the following lengths of off- road surface:

- 5k: 0.5 km
- 10k: 1 km
- 10 miles: 1.3 km
- Half marathon: 1.6 km
- 20 miles: 2.1 km
- Marathon: 2.6 km

For races which exceed the above amounts of off-road surface it may be impossible to issue a certificate of course accuracy. These races should therefore be classed as multi-terrain on the licence application form.

### **Multi Terrain**

Multi Terrain, although not a discipline recognised within UKA Rules for Competition, is closely aligned to Road Running. Multi Terrain races are defined as those up to and including marathon distance which do not meet the full definition of Road Races within the rules, but are run over at least 40% tarmac, concrete or paved surfaces.

Road Running rules and standards, where applicable, are applied to Multi Terrain races. Multi Terrain races shall be licensed by runbritain. Where a Multi Terrain licence has been issued the race prospectus and entry form should state that the event is held under UKA Rules for Road Running, where applicable to Multi Terrain events.

Any off-road race that falls outside the definition of Multi Terrain shall be held under the UKA Rules for Competition for the endurance discipline that most closely reflects the nature of the event, and licences for such races shall be issued by the organisation that manages and regulates that endurance discipline.

### **Trail**

UKA defines Trail races as follows:

- (1) Trail races are races that are predominantly along:
  - (i) footpaths, bridleways and towpaths over which there is a public right of way.
  - (ii) private paths with the consent of the owner or occupier as appropriate.
  - (iii) trails across land and coastal margins where relevant legislation

- grants the right of public access on foot. (Such legislation includes the Countryside and Rights of Way Act 2000, and the Land Reform (Scotland) Act 2003)
- (2) Trail race routes may include connecting stretches of public road and/or private or public land without a path when the owner's permission has been obtained, if required for legal access.
  - (3) Courses of up to marathon distance, i.e. 42.2km, which are less than 60% are not to be classified as Trail Races.
  - (4) For Championship events the courses must be at least 60% trail if the race is 40 miles or more, 70% if the race is over 20 miles but less than 40 miles, and 80% if 20 miles or less.
  - (5) Trail races may be of any length. Their length and the total climb should be measured using accurately scaled maps, such as Ordnance Survey maps, or GPS systems.
  - (6) Most trail races are traditional point to point races, but some involve unusual features:
    - (i) 'Supported Races' are those where coaches, families or team managers are permitted to give competitors refreshments or provide changes of clothing along the course.
    - (ii) 'Self Sufficiency Races' require competitors to carry everything they need, except that in ultra races and in hot weather the organiser may provide water at intervals to prevent dehydration.
    - (iii) 'Kanter Races' require competitors to choose their own routes using trails and a sequence of visiting check points. These are given as grid references on Ordnance Survey maps. Any restrictions about the choice of route should be made clear in the rules of the particular race.
    - (iv) 'Staged Races' are those where the course is broken into separate stages with rests at the end of each stage. Competitors run every stage and their times are aggregated to determine the winner.
    - (v) 'Extreme Races' are self-sufficiency races of over 100km that include a section most competitors will run at night.
  - (7) 'Waymarks' are permanent official signs.
  - (8) 'Routemarks' are temporary signs placed out by race organisers.
  - (9) 'Ultra Distance' is defined as further than a marathon, ie over 42.2km.

### **Cross Country**

A cross country course is designed to be appropriate for a number of races held on one day over varying distances and as such will be on a lap course that will usually be between 1,500 and 5,000 metres in length. The course will normally be suitable for spiked shoes and should not include road or other hard surfaces although it is recognised that non-championship races may include sections that make the course more suitable for studs. When an event is held under World Athletics Rules then World Athletics Rule T56 provides a definition of the nature of course required.

### **Fell and Hill**

Fell Running is a traditional activity in the UK with a long history; races are held on a wide variety of courses on mountains, hills and fells. Courses are graded into categories which are defined in UKA Rules for Competition; the grading is determined by the race distance and severity of climb. Some courses may require runners to have navigational skills and many “A” category races may prove hazardous and should only be attempted by those with the necessary experience to cope with the adverse conditions that may occur in remote mountain locations.

### **Mountain Running**

Mountain Running is recognised internationally by World Athletics (via its association with the WMRA) and European Athletics. Mountain Running races take place on primarily off road terrain on well-defined routes, requiring no navigation or route choice. The profile of the course involves either considerable amounts of ascent (for mainly uphill races), or ascent/descent (for up and down races with start and finish at the same level), with no dangerous sections. The average incline of the course should be a minimum of 5% (or 50 meters per kilometre) and not exceed 20% (or 200 meters per kilometre). Runners are not allowed to use supplementary aids such as poles.

### **Race Walking**

Race Walking is a progression of steps so taken that the walker makes contact with the ground, so that no visible (to the human eye) loss of contact occurs. The advancing leg must be straightened (i.e. not bent at the knee) from the moment of first contact with the ground until in the vertical upright position. (Rule T54(2)).

Race Walking events are held on surfaces that allow for the judging of

the event. This should normally be either track or road surfaces following the requirements and standards applied to track or road running events respectively.

### **Mass Participation Race**

A road race which accepts entries from runners of all abilities where the 'race' is for runners wishing to compete against others and the clock. Age group categories may be incorporated.

### **Parkrun**

Not considered races (ie not licensed or operated under UKA Rules), parkrun events are free to attend, weekly, timed 5km runs. Results are presented in time order however there are no performance related prizes or medals and the first person across the line is termed the 'first finisher' not the winner. They may cover any reasonable surface such as tarmac, gravel paths, grass, forest trails, pavement and meadow but they do not run on public highways. Although some parkrun events will be certified as 5km, in most cases this is not guaranteed especially as courses can change from week to week in order to accommodate local conditions such as flooding or fallen trees.

parkrun events seek to support rather than compete with paid races and although runners of all abilities are welcome, the focus is on recreational running and increasing participation.

### **Fun Runs**

Fun Runs do not usually operate under rules for competition in respect of age groups, gender and distances. There will be no official timing and prizes for performance (1st, 2nd, 3rd etc.) for individuals or teams. If there are awards (other than spot prizes) then all participants must receive the same award. An event cannot be considered to be a Fun Run if awards are made based on performance or results published with times. (see also Pushed Wheelchair and Buggy section below)

### **Closed Road**

- All roads on which participants are running are closed to all traffic.
- A road (dual carriageway or road with multiple lanes) with the running route segregated by cones and or barriers, would be deemed as a closed road.



## Open Road

- The carriageway on which participants are running is open to traffic.
- Where the start / finish area is closed to traffic, and the remainder of the course is shared with live traffic
- Where a section of the course is closed within the course and the remainder shared with live traffic.

## Pushed Wheelchairs and Buggies

### Guidance for Mass Participation Races and Fun Runs

All races operated under World Athletics, IPC and UKA Rules for Competition require all competitors to complete a course without assistance from any other person or source. Road Running has expanded to incorporate “Fun Runs” and fund raising activities and as such frequently generates entries from persons wishing to push a wheelchair or buggy and these entries may include entering the person being pushed as a competitor. To help accommodate entrants, please note the following guidance:

1. Buggies, pushchairs or strollers may participate in ‘fun runs’ held on Closed Road, Traffic Free Parks and Estates.
2. Buggies / pushchairs / strollers or other wheeled apparatus, including electric and hand-cranked chairs may participate in ‘fun runs’ on condition that the event organiser has undertaken a full risk assessment to determine that they can participate safely in accordance with that assessment.
3. Pushed participation in the mass participation element of Closed Road Races, Traffic Free Parks and Estates in any UKA Licensed Race held under UKA Rules for Competition will be considered on an event by event basis under the following conditions:
  - The Competition Provider must undertake a full risk assessment for all aspects of the event, see guidance that follows in this Appendix.
  - The Competition Provider has made such adjustments as are reasonable and required to accommodate wheelchair participation.
4. Competition Providers must make such adjustments as can be reasonably made to accommodate all participants, but Competition Providers must, in doing so, remember to also observe their duty of care responsibilities.

## **Risk Assessment**

The Competition Provider must undertake a Risk Assessment to determine whether their event is suitable for wheelchair and / or pushed wheelchair participation.

### **Risk Assessment: Wheelchairs**

#### Considerations when undertaking a risk assessment for wheelchair athletes and pushed wheelchairs:

- Number of participants
- Race distance
- Cut off times
- Should they start before the main race, and if so, by how long?
- Is there room for the lead vehicle to overtake when it catches the wheelchair athlete?
- Consider putting a cyclist with the wheelchair athlete if a racing wheelchair
- Width of running route (should be single file on open roads)
- Is it better for a non-racing wheelchair to start at the rear of the field?
- What is the terrain of the course, is it hilly, is it suited for wheelchair participation?
- Are the surface conditions suitable for a wheelchair? (For example, speed humps/potholes etc)
- Is your event a two-lap course? If yes, you will need to consider the risk of collision with other athletes
- Is your course out and back? If yes, then you may need to consider segregating runners going out and returning.
- If a racing wheelchair/s are participating and the race organisers must determine whether they have the resources or the course design to allow the wheelchair racer to start before the rest of the field.

#### Considerations when undertaking a risk assessment for the pushing of persons in buggies / pushchairs / strollers / other wheeled apparatus: Fun Runs Only

- Emphasise that it is not a race and is non-competitive.

- Have all reasonable adjustments been made to accommodate all participants?
- Is the buggy / pushchair / stroller / other wheeled apparatus designed for being pushed by a runner?
- The terrain of the course - is it hilly, is it suited for buggy / pushchair / stroller / other wheeled apparatus participation?
- Are the surface conditions suitable for a buggy / pushchair / stroller / other wheeled apparatus?
- If it's a multi lap course it may prove a collision hazard for other athletes on subsequent laps, or if an out and back course, is there a need for segregating runners going out and returning?
- If there are steep descents does the buggy / pushchair / stroller / other wheeled apparatus have brakes?
- Is the child securely harnessed in the buggy / pushchair / stroller / other wheeled apparatus and is it well maintained? The parent / guardian should confirm that they are satisfied that the person is securely harnessed, and the equipment is fit for purpose.
- Does the person pushing the buggy / pushchair / stroller / other wheeled apparatus know the course?
- Considerations for powered wheelchairs within a Fun Run:
  - Battery life and the possibility of loss of power during the run
  - Weight of the wheelchair should recovery be required
  - Physical recovery of the person and chair.
- Considerations for hand-cranked chairs within a Fun Run:
  - Potential speed of the machine and the effect on other participants.
- General considerations:
  - Punctures

**Worked examples of Risk Assessment documents can be found in runbritain Fact Sheet 4.**

### **Event Day Actions**

An athlete given permission to compete in a wheelchair, upon arrival to the event may still be refused entry by the Race Organiser on the following grounds:

- That a wheelchair and / or the athlete by using it represent a health and safety risk based on unforeseen circumstances on the day i.e. weather conditions
- It is hand-cranked, electric or propelled by any another means and not self-propelled.
- If the Race Organiser has not been made aware in advance of any specific requirements so that provisions can be put in place ahead of the event, unless those specific requirements cannot be met by the race organiser carrying out reasonable adjustments.
- If the wheelchair appears to have noticeable defects.

## GOVERNANCE AND COMPETITION PROMOTION RESPONSIBILITIES

The following table provides guidance on the role of each of the national bodies responsible for the management of Endurance disciplines and the promotion of competition. The function of management includes: regulation of competition; disciplinary issues; licensing of events; and producing fixture calendars. UKA recognises the role of a number of independent organisations in the management and regulation of competition, including the Fell Runners Association (FRA), Trail Running Association (TRA) and Race Walking Association (RWA).

	<b>Governance</b>	<b>Competition Promotion</b>
UKA	Yes	No
British Athletics	No	Yes
Athletics Northern Ireland	Yes	Yes
England Athletics	Yes	Yes
Scottish Athletics	Yes	Yes
Welsh Athletics	Yes	Yes
English Cross Country	No	Yes
English Road Running	No	Yes
runbritain	Yes	No
FRA	Yes	Yes
Northern Ireland MRA	No	Yes
Scottish Hill Runners	No	Yes
Scottish Hill Racing	No	Yes
Welsh FRA	No	Yes
RWA	Yes	Yes
TRA	Yes	Yes
UK Counties Athletic Union	No	Yes

### Licensing Processes

All races in the UK are required by UKA Rules for Competition to be licensed. Licensing processes differ from discipline to discipline and the table below indicates which body you will need to make an application to. The race licence demonstrates to competitors and insurers that the race is promoted to governing body standards and that UKA Rules for Competition will apply; it does not mean that UKA public liability insurance will apply – insurance cover only applies when the organising body is affiliated to one of the four National Associations and a licence awarded to the race.

Cross Country Licence standards have been introduced in the 2019 - 2020 season. A copy of the Standards is available at <https://uka.org.uk/competitions/useful-documents/>.

	Cross Country	Fell	Mountain	Road (inc MT)	Trail	Ultra	Walks
England	EA*	FRA	UKA	runbritain	TRA	UKA	RWA
Northern Ireland	ANI	NIMRA	NIMRA	ANI	ANI	UKA	ANI
Scotland	SA	SA	SA	SA	SA	UKA	SA
Wales	WA	WA	WA	runbritain	WA	UKA	WA

EA\* Cross Country licences in England are issued by Midland Counties AA, Northern Athletics and South of England AA respectively.

### Key

ANI: Athletics Northern Ireland

EA: England Athletics

FRA: Fell Runners Association

NIMRA: Northern Ireland Mountain Running Association

RWA: Race Walking Association

SA: Scottish Athletics

TRA: Trail Running Association

## **HEALTH AND SAFETY GUIDANCE FOR OFF TRACK ENDURANCE EVENTS**

To help support the delivery of safe, enjoyable endurance activity the UKA Endurance Advisory Group has produced the following good practice guidance document for organisers of off track events (Fell, Mountain Running, Cross Country, Trail, Race Walking and Road), Club Secretaries and County Secretaries.

NB. This document sets general standards and more detailed discipline specific guidance can be found in the documents referenced at the end of this section.

### **Marshal Instructions:**

Marshals play a hugely important part in the successful management of safe endurance events and it is critically important that all marshals are provided with details of their specific role and responsibility via a pre event briefing AND clear written instructions. Key areas that should be covered in the briefing and written instructions include:

- A map of the course/route showing – start/finish, direction runners are coming from and going to, position of first aid points, entrance and egress point of venue, access point for emergency vehicles giving either grid reference and or post code.
- A map of the course showing relevant Marshal Positions.
- A description of Marshal Positions, including street/road name and post code, grid reference or GPS coordinates as appropriate.
- The method of communication – for example: mobile telephone or two way radios (whatever systems you are using check that you have full course coverage before the event).
- Emergency contact telephone numbers and procedures to follow in the event of an incident/emergency.

## Medical Provision:

Extensive medical guidance for road running events is available at <http://events.runbritain.com/rdp/>; all event organisers should provide the following information to their medical provider:

- Number of participants.
- Age Groups.
- Distance.
- Terrain – Road / Cross Country / Fell / Mountain / Trail.
- Map of the Course.
- Emergency procedures.
- Event Risk Assessment.
- Date and time of the event – Helpful for indicating types of weather you are likely to encounter.
- Any past history of accidents, incidents, hospitalisation or deaths.

Using this data, your medical provider will determine the number of personnel they recommend to support your event; what equipment they will bring; their staff qualifications and the number and type of vehicles. The provision should also take account of anticipated weather conditions. This, in effect, provides you with a medical plan that supplements your medical risk assessment.

It may be appropriate for certain events where large numbers are involved or where there is a particular risk to notify your nearest Accident & Emergency Hospital and Ambulance Trust giving details of the event and its venue, including access points (post code/grid reference). For Fell and Trail it may also be appropriate to inform Mountain Rescue or HM Coastguard.

Once the Medical Provider has been appointed you will need to agree:

- The most effective way of reacting to and reaching the casualty – medical positions spread around the course or mobile units working from a specified central position.
- The method of communication between the race organiser and medical provider.



## Risk Assessment:

UKA has produced a standard risk assessment template that is to be used across all disciplines. The template, which can be found in Fact Sheet 4 at <http://events.runbritain.com/rdp/>, provides examples of the key areas that event organisers should be covering when undertaking a risk assessment.

The risk assessment is a dynamic document and needs to be compiled pre-event and regularly reviewed and updated, even on event day. When the document is updated note the amendment date or reference.

It should identify who is responsible for various actions but ultimately the Competition Provider / Race Director owns the document and process. A risk assessment should account for specific conditions that are likely to be in place on the day of the event and must be conducted at the time your event is being staged to check on features such as shop opening times and church services. For disciplines such as Fell and Mountain Running it will be important to make an assessment of risks based upon anticipated weather conditions.

- It should include (or reference) other supporting organisations risk assessments, as described above – Medical Provision.
- The risk assessment is unique to your event.
- Whilst there is no direct legal requirement upon volunteer groups to carry out a Risk Assessment they most certainly have a duty of care to participants which (in the event of a civil claim) would require the group/ organisers to demonstrate that a suitable and sufficient assessment of risks had been carried out by a competent person; the simplest way of which would be to conduct a risk assessment.

The Referee is the final arbiter at all times at Cross Country events.

The event risk assessment should be fully integrated with the Event Plan and available for inspection as required.

### **Athlete Screening:**

There are times when heart disease or problems remain unknown or undetected. Many sports already use screening for funded or elite athlete programmes. Athletics would like to bring to your attention the availability of Cardio Screening through [www.c-r-y.org.uk](http://www.c-r-y.org.uk) (Cardiac Risk in the Young)

### **Reference Documents:**

This guidance document has been produced to help organisers implement the essential elements of a safe endurance event. The nature of the different disciplines of endurance running inevitably means that different events will have differing safety requirements and further details can be found in the reference documents listed below. Specific circumstances particular to Fell & Hill and Trail races may apply as a consequence of the nature of terrain used and the length of races. You should refer to the Fell and Trail sites below for further guidance and note that FRA Safety Guidelines take precedence when planning Fell and Hill races.

**Road Race:** Handbook and Medical Guidelines :

<https://www.runbritain.com/race-directors-club>

**Cross Country Handbook, Licence Application and Standards & Risk Assessment:**

<http://www.uka.org.uk/competitions/useful-documents/>

**Fell Running:** Safety Requirements, Organisers Safety Checklist and Guidelines for Organisers:

<http://fellrunner.org.uk/organisers.php>

**Trail Running:** <https://www.tra-uk.org/organisers>

**Race Walking:** apply road running standards.

## ROAD RUNNING

### The Event Adjudicator

An Event Adjudicator must be appointed for all Road and Multi Terrain races licensed by runbritain. Where a race series is staged at the same venue over the same course then only one race will need to be covered unless there are concerns raised within the Event Adjudicator's Report. The Event Adjudicator is responsible for assessing whether the Race Organiser delivers the event to runbritain Licence Standards. The Event Adjudicator reports to the Regional Panels and should issues be raised these are flagged for action. Subsequent licence applications by the race or race organiser cannot be considered until the Chair of the Regional Panel is satisfied that all issues have been addressed and resolved.

Experience and Knowledge requirements:

- Current Endurance Official (Level 2)
- BARR Scrutineer (BARR to identify and provide list)
- Current Race Promoters
- A good knowledge of Race Organisation
- Understanding of Risk Assessment
- A good communicator
- Awareness of Road Race Licence Standards
- Able to pass an online test if there are any concerns about an applicant's level of competence
- A buddy system operates for when undertaking their first event.

The Event Adjudicator will:

- Be covered by UKA Public Liability Insurance
- Be issued with Accreditation, access code to Race Director Portal and URL Number\*
- Be DBS Checked
- Submit the report online within 7 days of the race

\*This will need to be quoted by Competition Providers on application for a Licence. It will also provide access to complete Race Reviews online.

It will be The Event Adjudicator's role to:

- Undertake the review and make comment of the current "Checklist" against Licence Standards
- Understand the demands on the Race Promoters on race day and not to be a burden on this role
- Communicate with the Race Promoter pre and post event as well as on event day
- Offer advice, if sought, in a constructive manner

Note: For smaller races (entries less than 300) the role of the Event Adjudicator and Race Referee can be undertaken by the same person provided they hold the appropriate Endurance Official's qualification and feel able to undertake both roles.

### **Role of Regional Panel**

- Review Event Adjudicator's Report
- Review standards of Event Adjudicator Reports
- Make recommendations to Race Promoter and runbritain for agreement and implementation of recommendations prior to issue of Licence to his/ her next event.
- Emphasis should be given to areas such as:
  - Was start / finish traffic free?
  - Was there a risk assessment undertaken and available?
  - Was the measured course run on the day?

### **Regional Panel Chair's Role**

- Liaise with the Race Promoter for feedback
- Implement flagging on the system where agreement can't be reached with the Race Promoter and concerns continue to stop automatic approval of future licences. Any restrictions on future licences must cover the individual, the race and organisation to cover all eventualities.
- Liaise with runbritain
- Ensure reports and close outs are undertaken in a timely

manner

### **Competition Provider/Race Organiser**

The Race Organiser has overall responsibility for the event. All pre-event, event day and post event decisions will be under his or her jurisdiction.

Pre-Event Planning will cover;

- The management structure and delivery mechanism
- Obtaining UKA Road Race Licence and Course Measurement Certificate (if required)
- Consultation and agreements with landowners, local authorities, safety advisory group, emergency services, the community, engagement of contractors, appointing medical services, obtaining consents, obtaining licenses if required, provision of event infrastructure
- Undertaking written risk assessments

### **Race Referee**

Appointment: the Referee and all other officials are appointed by the Race Organiser

The Race Referee is responsible for ensuring that UKA and any local rules of competition are interpreted and implemented in a fair manner. He / she may assist the Race Organiser to provide sufficient endurance officials (or volunteers) to cover timing and time recording, judge / recorders, funnel controllers and other duties that may be required.

- Receive any objections/appeals regarding published results
- If published at the event – Appeal to be lodged at the event
- If published after the event – Appeal, via The Race Organiser, to be lodged within 14 days of the results being published
- The Race Referee will receive a copy of the entry list, to include late entries
- In road relays no changes may be made in the declared order of running without the prior approval of the Race Referee and

the Promoter

- The Race Referee may disqualify any runner who does not follow the correct course or obey the instructions of Police or race officials
- The Race Referee should verify results before they are published

Endurance Officials, including those qualified to referee, can be identified and contacted through the appropriate County Officials Secretary.

## **COMPETITION ISSUES**

### **Gun and / or Chip Timing**

UKA Rules for Competition do not include a rule that requires the use of either gun or chip times for age group awards. The only rule included (T19.24) requires the use of gun times for any race. Races may use either system but whichever is in use should be clearly notified to all competitors, before the day of the race. In races where wave starts or high numbers of runners are participating, resulting in runners taking some time to cross the start line, then it is advisable to use chip times for team and age related awards.

### **Awards and Prizes**

The Competition Provider will determine the nature of awards based on the status of the event (eg championship or open race), the profile of entrants and available budget. In all cases, equality of awards and prizes across all categories including gender and age should be achieved. (See the note in the paragraph below – Additional Gender Categories)

### **Additional Gender Categories**

Competition Providers promoting road races may offer a third non binary gender option within their events and present awards and prizes in line with other categories of competitor. For ranking purposes, only Male and

Female gender categories will be recognised.

### **Use of Audio Headsets and Mobile Telephones by Runners**

World Athletics Rules do not permit the use of any form of audio headset or mobile telephone within the competition area (which includes road and cross country races). From April 2016 UKA Rules for Competition do not allow the use of headsets in any road race that is held on single carriageway roads that are open to traffic. (Rule T55 S5). Bone conducting headsets may be allowed in some races but it is possible that all headsets will be prohibited. UKA will support the Competition provider when applying this condition

The advice to Competition Providers is that their race risk assessment should take account of the possibility of runners wearing headsets or using telephones and apply local conditions appropriate to the findings of the risk assessment. If it is deemed unsafe then promoters may restrict use and disqualify any runner found to be contravening the instruction. UKA will support any race promoter taking such action.

Races in which audio headsets and mobile telephones should not be used include:

- Championships
- Cross Country
- On roads that are open to traffic
- On lap courses – including when closed to traffic
- Where runners must be alert to marshals' instructions

### **Guidance for Distances Appropriate for Young Runners**

UKA have clear rules (Rule T3) on the maximum race distances that are recommended for young athletes. These are in place to ensure that the health and wellbeing of the young person is paramount and that good practice in developing athletic skill and ability is followed. The best place to seek advice on running distances and training methods is through a local running club or group with qualified coaches and/or leaders. UKA recognises that some young people may participate in a race over a distance longer than that stated in the rules/guidance for purposes of a charity run or something similar. A one off race completed over distance

is unlikely to be a problem for a young person but repeated runs are not recommended.

### **Running with Dogs**

Dogs are not allowed in any licensed competition unless a special exemption has been granted to a runner accompanied by a medical assistance dog.

## **TECHNICAL OFFICIALS (ENDURANCE)**

An education and training process has been developed to assist Technical Officials who wish to work at endurance events to progress through the structure whilst acknowledging that many will want to achieve the basic level of qualification to help at their local club events. The process is managed at a policy level by the UKA Endurance Education and Development Sub-Group which is responsible to the UKA Technical Advisory Group. Delivery of courses is managed by the four National Associations.

The responsibility for the accreditation and upgrading of Endurance Officials up to Level 3 is delegated to six administrative areas within the UK: Northern Ireland, Scotland and Wales and three areas in England.

The three Tri-Regional groupings for England are the Northern group (North-East, North-West and Yorkshire and Humberside), the Southern Group (East, London and South East) and the Midlands and South Western Group (East Midlands, West Midlands and South West).

Accreditation of Endurance Officials to Level 4 and above is managed by the UKA Endurance Education and Development Sub-Group, and where appropriate, making recommendations for selection for major national meetings.

The range of duties incorporated in Endurance officiating includes: referee, line judge, funnel judge and recorder, timekeeper recorder, funnel control, chip management, clerk of the course (cross country), marshal, start management and lap recording. Qualification as a Starter and Timekeeper is managed through the track and field officials' process



as the duties are deemed to be similar.

All qualified Technical Officials must hold a current DBS certificate and receive a pass and licence that recognises their level of qualification. Licences must be renewed every three years by updating the DBS certificate.

Any changes to the process during the lifetime of the Rule Book will be published on the British Athletics website in Competitions / Officials / Endurance Officials. Details of planned courses may be obtained from your National Association.

### **Endurance Officials' Pathway**

The Endurance Officials' Pathway describes the process and requirements for progressing from Level 1 to Level 5 International Official; the effective level for operating at major domestic competitions in the UK is Level 4 and Level 4 Officials fill the majority of appointments in international races held in the UK.

The Pathway diagram, and other guidance documents, can be found at <http://www.uka.org.uk/competitions/officials/endurance-officials/> along with the record of experience form and the Health and Safety Guidance leaflet.

### **Getting started**

Having decided that you want to be involved in endurance events in an official capacity, contact should be made with your local club(s) and/or event organisers. Your initial involvement may be at what you might consider to be a basic level, for example, as a marshal. For those interested or who may develop an interest in being involved in a wider or at a higher level, the Endurance Officials' Pathway for development and licensing is described below. More comprehensive guidance can be found in the booklet "Getting Started as an Endurance Official" which can be found at: <https://www.englandathletics.org/officials> or through the appropriate National Association.

## **Level 1: Endurance Official**

For those with some experience of working at events and / or for those who wish to continue along the Endurance Officials Pathway, attendance at a Level 1 Endurance Officials' Course is essential. The Level 1 Endurance Officials course is a half day classroom based tutored course. In addition to attending a course it will be necessary to complete four separate competition experiences showing evidence of carrying out various roles and responsibilities. The experiences include course marshalling, stewarding, recording or assisting at the start or finish.

You should record your experiences, on an Annual Record of Experience (RoE) form, as these will need to be included in your Application for Accreditation as a Level 1 Endurance Official. You should aim to record these experiences immediately after an event. After completing the required number and type of experiences, submitting a UKA Application for Accreditation form as a Level 1 Endurance Official and completing a Disclosure and Barring (DBS) check you will then be eligible to be licensed as a Level 1 Endurance Official.

The RoE should be submitted annually to your National Associations' Officials Administrator.

## **Level 2: Endurance Official**

If you wish to progress to the next level, as a Level 2 Endurance Official, you will need to complete an additional six competition experiences and study three of the following Level 2 Modules:

- Race Referee
- Judging and Recording
- Race Director
- Start Director
- Finish Director
- Sector Marshal

If you are looking to referee at local / club races you must complete the

Race Referee module at this stage together with the Risk Awareness course (see below). You should also submit a UKA Application Form for Accreditation as a Level 2 Endurance Official. When licensed as a Level 2 Official you can referee local / club road races typically up to 600 runners and cross country races up to 300 runners.

### **Level 3: Endurance Official**

The next level of progression requires completion of an additional ten Competition Experiences detailed on a Level 3 Application for Accreditation, the obtaining of one positive report on how you performed your duties, together with completion of the remaining three Level 2 Course Modules (see above). After satisfactory submission of UKA Application Form for Accreditation as a Level 3 Endurance Official you would then become licensed as a Level 3 Official. This would enable you to referee regional races (or home country equivalent) typically up to 3,000 runners in a Road Race or 300-400 in a Cross Country race.

For these higher levels, relevant experience includes being the Clerk to the Course, Course Director, managing a sector such as the start or finish or group of marshals, lap recording, setting up the course or, for County and smaller races, acting as the referee.

### **Level 4: Endurance Official**

The UK Athletics Level 4 is a progression from Level 3 that both consolidates learning at Level 3 and prepares the official to operate at national and international level through the introduction of additional modules including meeting management.

Detailed guidelines for applicants for Level 4 are on the UKA website at <http://www.uka.org.uk/competitions/officials/endurance-officials/>

To achieve Level 4 officials must:

- Attend a generic workshop delivered by an approved tutor
- Complete a logbook.
- Work with an appropriate mentor

- Submit logbook for assessment and undergo assessment of competence and knowledge and understanding of UKA and World Athletics rules and the differences between them by an approved assessor.

Duplication of reports is not acceptable in any circumstance other than as described below where one report can be carried forward from a Level 3 application. To achieve progression to Level 4 positive reports on all the following duties are essential:

- Referee or Assistant Referee
- Start Area Coordinator / Start Director
- Finish Area Coordinator / Finish Director
- Clerk of Course / Course Director

All reports assessing an Official's competency to perform at level 4 must be completed by accredited Level 4 Officials who have been at that Level for at least 2 years.

Reports must be submitted by at least 2 different accredited officials, and the annual record of experience forms needs to show at least 20 experiences as a Technical Official over a designated period of time (as a guide this would normally mean a minimum of 3 years) across a number of County, Regional and National races in varying roles and should include evidence of at least 12 experiences in senior positions.

If the meetings are all local meetings the candidate is unlikely to have sufficient experience to move straight to Level 4 and if they have not travelled out of their local area this may show a limited commitment to travel. It is important that the candidate carries out the full range of duties relevant to their discipline.

All candidates must include sufficient detail on their Record of Experience so that it is clear which duties they have carried out. Experience of refereeing at a local level event is essential for progression to Level 4.

Tri-Regional Peer Groups will review applications for progression to Level 4 annually in September / October of each year. The outcomes of

the application will be communicated to applicants in January following the meeting and decisions of the UKA Endurance Education and Training Sub-group.

The National Endurance Peer Group requires evidence of competence to make a sound decision. Reports must be obtained from both road racing and cross-country races; however, there is no specific ratio of how many are required from each.

The positive report submitted for accreditation at Level 3 must demonstrate managerial experience and can be used as one of the 4 reports required for accreditation to Level 4 if it is less than 3 years old at the time the application for accreditation is made.

Officials who have satisfied the requirements of the Level 4 accreditation system will be listed as Level 4P for two years after qualification but will immediately become eligible to receive information regarding selection for national and international competitions under the auspices of UKA. This is a probationary period during which positive assessments are required for the Official to remain eligible for consideration for selection for such competitions. Should such assessments not be received the official will retain their Level 4 designation but will no longer be eligible for selections as mentioned above.

The Level 4 qualification recognises all Technical Officials at that level as National Technical Officials, equivalent to Level 1 officials under the World Athletics TOECS (Technical Officials Education & Certification System).

Any Level 4 official who has not submitted their records of experience and availability forms for a period of three years will be considered to be inactive at National level and will no longer receive availability requests. They may apply for re-instatement through their TRNG.

## **Risk Awareness Course**

All Endurance Officials must attend the Risk Awareness module – a half day course, usually held in conjunction with the Level 1 course, to qualify as an Endurance Official. Acknowledging that you have read and understand the Health and Safety Guidance Leaflet should be recorded in your log book.

The ultimate responsibility for risk assessment at road races rests with the Race Director but Race Officials should be aware of all implications should the need arise.

# INDEX OF TECHNICAL RULES

	<i>Rule references</i>
<b>A</b>	
Abbreviations (start lists, results) .....	C25.4
Absence during competition .....	T25.19
Accidents - Precautions: see Safety	
Adhesive tape .....	T24.4; T25.3.1, T27.2.2
Advertising – International Competitions .....	G8
Advertising and Sponsorship – UKA .....	G8 S1; T5 S1
Age Categories	
Masters .....	T3.1
Minimum ages .....	T3.1 (Note ii)
U18 .....	T3.1
U20 .....	T3.1
Age Groups: UKA .....	T3 S1
Cross Country and Road .....	T3 S3
Fell, Hill and Mountain Running .....	T3 S4
Track & Field and Race Walking .....	T3 S2
Trail Running .....	T3 S5
Amalgamation of Clubs .....	G2 S3 (12)
Announcer – Duties .....	C13
Anti-Doping UKA: Clean Athletics .....	G4 S1
Appeals – see Protests & Appeals	
Area Technical Officials (ATOs) .....	
Appointment .....	C3
Duties .....	C8
Assistance	
Cross-Country .....	T56.7
Field Events	
Bandage at the wrist .....	T6.4.3
Belt for support .....	T6.4.3
Elbow protection .....	T6.4.3
Gloves .....	T32.4.3
Knee support .....	T6.4.3
Taping of fingers and hand .....	T32.4.1
Throwing Events .....	T32.5
Use of substances .....	T32.4.4; T32.5.1
Wind sock .....	T25.4.2
General	
Advice .....	T6.3.5
Appliance .....	T6.3.3
Communication .....	T6.4.1
Mechanical aid .....	T6.3.4
Medical .....	T6.1; T6.4.2

	<i>Rule references</i>
Mobile phones .....	T6.3.2
Personal electronic equipment .....	T6.4.4
Personal safeguards .....	T6.4.3
Shoes .....	T5.2; T5.6
Technical device .....	T6.3.1
Mountain Races	T57.8
Race Walking .....	T54.10
Track Events	
Drinking and sponging .....	T17.15
Intermediate times .....	T17.14
Pacing .....	T6.3.1
Receiving Physical Support .....	T6.3.6
..	
Athlete bibs .....	T5.7-9; T5 S1
Perforations .....	T5.8
Worn as issued .....	T5.8
Road Races .....	T5 S2
Athletes' Representative – International .....	Definitions, G7
Athletes' Representatives - UK.....	G7 S1
<b>B</b>	
Banking (Indoor events)	
Angle .....	T43.3
Finish line in relation to banking .....	T44.7
High Jump approach from banking .....	T49.2
Horizontal Jumps approach from banking .....	T51
Pole Vault approach from banking .....	T50
Start position in relation to banking .....	T44.7
Baton	
Dimensions .....	T24.5
Dropping the baton .....	T24.6
Position in relation to takeover zone .....	T24.7
Starter's Assistant's responsibility .....	T16.5
Bell .....	C24.2
Betting .....	G5 S1
Bibs – see Athlete bibs .....	
Blocks – see Starting blocks .....	
Bona fide effort – see also Disqualification	T4.4.3 and Note; T17.2; C31.1
Break line	
Dimensions .....	T17.5
For 800m and appropriate relays .....	T17.5; T24.13-16
For starts split into two groups .....	T16.10
Indoor provision .....	T44.6
Use of cones to indicate line .....	T17.5



*Rule references***C****Cages**

Discus ..... T35

Hammer ..... T37; T37 S1-2

Joint hammer and discus ..... T37.6

**Calibrated bicycle**

Method intended for measuring road courses ..... T55.3 (Note (i), (ii))

**Call Room**

Call Room Referee / Judges. .... C18.5; C28

Failure to report ..... T4.5

Medical Assistance after leaving ..... T6

Relay Team Declaration ..... T24.11

UKA Technical Officials ..... Appendix 3

**Cartwheeling technique – see Shot Put****Caution – see Warnings and Disqualification****Centralised Landing Area**

T29.6 (Note)

**Certification**

Implements ..... T32.1-3

Road Race Courses ..... T55.3

Tracks ..... T2

**Change of competition area or time**

T25.20

**Check marks**

Field Events ..... T25.3

Relay ..... T24.4

Track events other than Relay ..... T17 (7)

**Clerk of the Course - Duties**

Appendices 3-4

**Clothing**

General regulations (including Indoors) ..... T5.1

**Clothing: UKA Competition**

Lettering and Logos ..... T5 S1

Race Walking Conditions ..... T5 S1

Track and Field Footwear ..... T5 S1

**Colleges – see Eligibility to compete****Combined Events**

Age Groups Younger than WA Age Groups ..... T39 S1

British Records ..... C33 S1

Competing order ..... T25-6, T25 S2

Conditions for Records ..... T39.8; C31.18

**Decathlon Event Order**

U18 Boys, U20 &amp; Senior Men ..... T39.2

U20 &amp; Senior Women ..... T39.4

Delay a trial ..... T25.18

Failure to attempt to start ..... T39.10

False start ..... T16.7; T39.8.3

Height progression ..... T39.8.4

**Heptathlon Event Order**

	<i>Rule references</i>
Indoors	T53.3
Outdoors	T39.3; T39.5
Indoors	T53
Number of trials	T39.8.1
Pentathlon Event Order	
Indoors	T53.1; T53.3
Outdoors	T39.1
Referee	T39.6-7; T39.10
Rest interval between events	T39.6
Scoring	T39.11
Ties in final classification	T39.12
Timing	T39.8.1; T39.9
Timing - Age Groups Younger than WA Age Groups	T39.7 S1
Competing order – Field Events	
Initial order	T25.5
Order for the last three rounds of trials	T25.6
Qualifying round	T25.5
UKA Field Events	<b>T25 S1 &amp; S2</b>
Competition Director – duties	C14, T145.3
Competition Year	G2 S6; T3 S1-3
Composite Teams	G2 S4 (4); G2 S8 (2)
County Qualifications – See Eligibility to compete	
Crossbars	T26.7
Cross-Country	T56
Course design	T56.1-3
Disqualification	T56.9
Distances	T56.4
Drinking / sponging and refreshment stations	T56.8
Headphones: UKA Races	T56 S2 (3)
Relays	T56.5
Safety	T56.7
Start	T56.6; T56 S2
Transponder timing	T19.T24
UKA Race entry qualifications	T56 S3
Venue	T56.1
Cross-Country, UK - see also Endurance Running UKA	Appendix 4
<b>D</b>	
Decathlon – see Combined Events	
Disability – Athletes with a	C18.8; IPC Rules
Discus Throw	
Assistance	T32.4-5
Cage (Discus only)	T35
Cage (Combined Discus and Hammer)	T37.6
Cage (Discus only) – UKA	T35 S1
Cage (Combined Discus and Hammer) - UKA	T37.6 S1
Circle	T32.6-8; T32 S3

**Rule references**

Circle (Leaving)	T32.17.1
Danger sector	T35.5
Failure	T32.14.2; T32.15-17
General conditions	T32
Implement details	T34.1-2
Implement details: Non-WA age groups	T34 S1
Landing sector	T34.10-12
Measurement of trial	T34.19-20
Disqualification from competition	
Assistance	T6.2
Combined Events	T39.8.3; T39.10
Cross-Country	T56.8
Identification of infringement in results	T4.4.3; T7
Offensive language	T7 S1 (2) and Note
Unsporting or improper manner / conduct	C18.5; T7.2; T16.5
Race Walking	T54.7; T54.10.8; T54.13
Track Events	
Bona fide effort	T4.4.3; T17.2
False start	T16.7
Hurdles	T22.7
Lane infringement	T17.3
Obstruction	T17.2
Relay	T24.6-11; T24.18-21
Steeplechase	T23.7
Dogs accompanying athletes	T55 S6 and Note
Doping Control Delegate - duties	C3.1.4; C7
Draw	
Combined Events	T39.7
Field Events	T25.5-6
Track Events	
Indoors	T45.2-3
Outdoors	T20.2-6; T20.5
Drinking / sponging and refreshment stations	
Cross-Country	T56.7
Race Walking	T54.10
Road Races	T55.8
Track Events	T17.15
<b>E</b>	
Electronic Distance Measurement	C28; T10.2
Eligibility to Compete: International Competition	G1, WA Chapter C3
Eligibility to Compete: UKA Competition	G2 S1
Clubs	G2 S2
Club Membership	G2 S3
Competition Conditions	G2 S4
Composite Teams	G2 S4 (4)

	<i>Rule references</i>
County, District and Area Qualifications	G2 S6
Eligibility and Exemption Applications	G2 S8
First Claim Status	G2 S5
Foreign Athletes	G2 S5
Higher Competition Clubs and Members	G2 S3
Home Country Qualifications	G2 S7
Ineligibility to Compete	G3 S1
Online Eligibility Transfer Process	G2 S3
Open Team Competition	G2 S9
Other Discipline Membership	G2 S5
Registration with National Association	G2 S1
<b>Endurance Running: UKA</b>	
Disciplines	Appendix 4
Endurance Technical Officials	Appendix 4
Governance and Competition Responsibilities	Appendix 4
Health and Safety Guidance	Appendix 4
Licensing Processes	Appendix 4
Road Running Guidance	Appendix 4
<b>Entries</b>	
Eligibility	T4
Simultaneous entries	T4.3
<b>Entries: UKA Competition</b>	
Fell, Hill and Mountain Running	T4 S3
Road Races	T4 S2
Trail Races	T4 S4
General	T4 S1
<b>F</b>	
<b>Failure</b>	
<b>Jumps</b>	T25.18
High Jump	T26.2; T27.1; T27.2
Long Jump	T30.1
Pole Vault	T26.2; T28.2; T28.4
Triple Jump	T30.1; T31.2
<b>Throws</b>	T25.18
Discus	T32.14.2; T32.16-17
Hammer	T32.14.1; T32.16-17
Javelin	T32.14.1 & .4; T32.16-17; T38.1-2
Shot	T32.14.1-3; T32.16-17
To participate	T4.4
False Start – see Start	
<b>Fell and Hill Running: UKA</b>	
Race Categories	T57 S1
Race Distances	T57 S1
Safety	T57 S1
<b>Field Events – General Conditions</b>	T25

**Rule references**

Absence during Competition	T25.19; UKA Note
<b>British Records</b>	C35 S1
Markers	T25.3
Practice Trials	T25.1-2; T25 S1
Qualification Round	T25.9
Ties	T25.22
Trials – see Trials recorded (Field Events)	
<b>Field Judge - Duties</b>	C19.4
<b>First Claim – see Eligibility to compete</b>	
Finish line	T18.1-2
Finish of Race	T18.1-2
Fixed time races	T18.3
Footwear – see shoes	
Fully Automatic Timing – see Photo Finish	
<b>G</b>	
<b>Gender categories – additional in Road Races</b>	Appendix 4
Gloves	T6.4.6; T24.6.2; T32.4.3
<b>Graded Competitions</b>	T3 S2(7); T9 S1
Green card	T16.5, T16.8(Note)
<b>H</b>	
<b>Hammer Throw</b>	
Assistance	T32.4-5
Cage	T37
<b>Cage: UKA</b>	T37 S1
<b>Cage Gate Panels: UKA</b>	T37 S2
Circle	T32.6-8; T32 S3
Leaving	T32.17.1
Danger sector	T37.7, T37 S1
Failure	T32.14.2; T32.16-17; T36.2-3
General conditions	T32
Gloves	T32.4.3
Implement details	T36.4-8
<b>Implement details: non WA Age Groups</b>	T36 S1
Landing sector	T32.10-12
Measurement of trial	T32.19-20 T19.1-12
<b>Hand Timing</b>	T55 S5; T56 S2
<b>Headphones – wearing by athletes</b>	T20.1-8
Heats – see also Draw	T20.9
Time interval between rounds	T20.3; T39.5; T53.2
Heptathlon - see also Combined Events	
<b>High Jump</b>	
Crossbar specifications	T26.7; T27.9
Crossbar support	T27.8

	<i>Rule references</i>
Elasticity of crossbar control	T26.7
End pieces	T26.7
Extraneous forces	T26.10
Failure	T27.2
Height progression	T26.4
Height progression – Combined Events	T39.8.4
Indoors	T49
Landing area	T27.10
Measurement of height	T26.5-6
Number of trials	T26.2.4
Runway	
Inclination	T27.4
Indoors	T49
Length	T27.3
Take off	T27.5
Ties	T26.8
Uprights	T27.6; T27.7
Higher Competition Clubs and Membership	G2, S3(4); G2 S4(3); G2 S8(2)
Horizontal Jumps	T29; T30; T31
Hurdles	
Construction	T22.2; T22.5
Counterweights	T22.2
Dimensions	T22.3
Disqualification	T22.7
Distances and specifications	T22.1
Distances and specifications – Non-WA Age Groups	T22 S1
Indoors	T47
Lane running	T22.6-7
Positioning on track	T22.1
World Record	T22.7
<b>I</b>	
Implements – see Official implements	
Indoor Stadium	T41
International Cross-Country, Road Running, Mountain Running and Trail Running Officials (ICOs)	
Duties	C8
Selection	C3
International Photo Finish Judge	
Duties	T19.20 (Note)
Selection	C3
International Race Walking Judges Selection	C3
International Road Race Measurer Selection	C3
International Starter Selection	C3
International Technical Officials (ITOs) Selection	C3

*Rule references***J**

## Javelin Throw

Assistance	T32.4-5
Failure	T32.14.1.,4; T32.16-17; T38.1-4
Implement details	T38.3-11
Implement details: non WA Age Groups	T38 S1
Landing sector	T32.10-12
Measurement	T32.19-20
Runway	T32.9
Leaving	T32.17.2
Unorthodox technique	T38.1.1
Valid throw	T38.1

Judges – see Officials of the Competition

Junior Men and Women – see Age Groups UKA

## Jury of Appeal

Duties	C3; T8.1; T8.7-10
Selection	C3

**K**

## Kerb

Indoors	T43.1; T43.4(Note)
Measuring track length	T14.1-3
Replaced by cones	T14.1
UKA Track Measurements	T14 S1

**L**

Lane Draw – See Seeding of Track Events

## Lanes

Infringement	T17.3-5
UKA: Running on the line	T17 S1
Number of lanes	T14.5
Width	
Indoors	T42.2; T43.2
Outdoors	T14.4

## Lap Scorers

Lap Scorers – Ultra Long Distance G9 ULTRA 3-4

Leagues G2 S3, G2 S4; T3 S2(2)

Leaving the competition area in Field Events T25.19

Leaving the track or course T17.6; T55.9

## Licence

Coach	G2 S3(16)
Competition	
Cross-Country	C1 S2; Appendix 4
Road Race	C1 S2; T4 S2; T55 S1; Appendix 4
Trail Race	C1 S2

	<i>Rule references</i>
Track & Field	C1 S2; Appendix 2
Official	G2 S3(16); T54 S1;
Location change in Field Events	T25.20
Long Jump	
Failures	T30.1
Indoors	T51
Landing area	T30.6-7
Leaving	T30.1.6; T30.2
Measurement of jump	T29.8-9
Plasticine indicator board	T29.3; T29.5; T30.1.1
Runway	T29.1-2
Take-off board	T29.3-4
Take-off line	T30.3-4
Wind measurement	T29.10-12
<b>M</b>	
Markers	
Field Events	T25.3
Lane	T16.8
Performance	T25.4
Marksmen – see Starter’s Assistants	
Marshal	C26
Masters	
Definition / General	T3.1; T3 S2-3
Discus Specifications	T34 S1
False Start - UKA	T16 S1
Hammer Specifications	T36 S1
Hurdle Specifications	T22 S1
Javelin Specifications	T38 S1
Shot Specifications	T33 S1
Steeplechase	T23 S1
Measurement Judge (Scientific)	C28
Measurements	T10; T14; T26.5-6; T29.8-9; T32.19-20
Medical Delegate	C3; T6.1
Medical examination	T6.1; T6.4.2
Medical staff – see Official medical staff	
Meeting Manager Duties	C13; Appendix 2; Appendix 3
Membership of a Club – see Eligibility to Compete	
Misconduct	G5 S1; T4 S1; T7 S1; T8 S1
Mixed Competition	T9; C31.1
Mixed Competition – UKA Competition	T9 S1
Mountain Races	T57
Course	T57.1



*Rule references*

Drink and refreshment stations	T57.5
Race conduct	T57.6
Safety	T57.4
Start	T57.3
Types of races	T57.2
<b>N</b>	
National Technical Delegate	Appendix 3
Neutral Athletes	WA Chapters 3.1/3.2
Number Cards – see Athlete Bibs	
<b>O</b>	
Obstruction	
Relay	T24.10; T24.15
Track Events	T17.2
Official implements – Throwing events	T32.1-2
Official implements: non-WA Age Groups	T33 S1; T34 S1; T36 S1; T38 S1
Official medical staff	T6.1; T6.4.2
Official time	
Cross-Country	T19.24
Road Races	T19
Track Races	T19.1; T19.8-9; T19.11-12; T19.22-23
Officials of the competition	C13; Appendix 3
Open Team Competition	G2 S2-5; G2 S9
Oral protest	T8.4
Organisational Delegate - duties	C4
Other Records	C36
<b>P</b>	
Participation "under protest"	T8.1; T8.4.1; T8.5
Pentathlon – see Combined Events	
Permission to Promote	C1 S1
Photo Finish	
Alignment of the camera	T19.15
Accuracy and certification	T19.14-18
Chief Photo Finish Judge	
Duties	C21; T19.19; T19.21; T21
Liaison with other officials	T19.19
Role in resolving ties	T21
International Photo Finish Judge	C3; C11; T19.20 (Note)
Numbers on shorts	T5.9
Number of cameras	T19.20
Official times	T19.22
Photo Finish Judges - duties	T19.21-23

*Rule references*

Reading and recording times	
Races up to 10,000m	T19.23.1
Races over 10,000m	T19.23.2
Races out of stadium	T19.23.3
Requirements of the System	T19.14-18; T19.20; T19.22
UKA Records	C35 S1
Zero control operation	T19.19
Zero control test for Records	C31.7.3; C31.14.1
Permission to Promote	C1 S1
Permits / Licences (all Disciplines)	C1 S2
Place of competition - change	T25.20
Plasticine indicator board – see Long Jump	T28
Pole Vault	
Box	T28.8
Crossbar	
Movement	T28.1
Specification	T26.7
Support	T28.10
Distance markers	T25.3.3
Failure	T28.2
Height progression	T26.4
Height progression, Combined Events	T39.8 .4
Indoors	T50
Landing area	T28.12
Measurement of height	T26.5-6
Number of trials	T26.2-4
Pole	
Break during vault	T28.5
Construction	T28.11
Falling towards bar	T28.4
Taping	T28.11
Protection against injury	T6.4.3; T28.10(Note)
Runway	
Inclination	T28.7
Length	T28.6
Uprights	T28.9
Use of substances	T28.3
Practice trials at competition area	T25.1-2; T25 S1
Programmes and Printed Material	C1 S1; T4 S1
Protests and appeals	
Competing "under protest"	T8.1, T8.4.1 T8.5
Cost of an appeal (deposit)	T8.7
Eligibility to compete	T8.1
Jury of Appeal	C3; T8.1; T8.7-10
Meetings with no Jury of Appeal or TIC	T8 S1
Oral Protest	T8.4-5; T29.9; T32.20

**Rule references**

Procedures	T8.2-6
Right of appeal	T8.4; T8.10
Start	T8.4
Time limits	T8.2; T8.7
<b>Q</b>	
Qualifying competition - Field Events	T25.9-16
Qualifying standards	T25.12-15
<b>R</b>	
Race Walking	T54
Chief Judge	T54.4
Definition of Walking	T54.2
Disqualification	T54.7
Drinking / sponging and refreshment stations	T54.10
Judging	T54.3
Judging – UKA Officials	T54 S1
Open Roads – UKA Safety Conditions	T54 S2
Pit Lane	T54.7.3
Posting Board	T54.4.3; T54.7.5-f)
Recorder	T54.4.3; T54.7(e-f)
Red Paddle / Red Cards	T54.4.1; T54.6; T54.7
Road courses	T54.11
Safety	T54.8
Transponder Timing	T19.24
World Records	C31.14-15; C31.19-20
Yellow paddle	T54.5
Reaction Time	T15.2
Records	
World Records	C31; C32
Combined Events	C31.18
Field Events	C31.17
Indoors	C31.13; 263, C35
Race Walking	C31.14; C31.19; C31.20
Relay	C31.3.4; C31.16
Road	C31.21
Track	C31.12; C31.14
U20	C31.2.2.4; C31.3.3; C33; C35
Other Records	C36
British Records	C35 S1
Red card – Referee	C18.5
Referees	
Appointment and duties	C18; Appendix 3
Combined Events	C18.3; T39.6-7; T39.10

	<i>Rule references</i>
Disqualifications / Protests – duties	C18.5; 142.4; 145 S1; T8.3; T17.2
Refreshments	
Cross-Country	T56.7
Race Walking	T54.10
Road Races	T55.8
Track Events	T17.15
Relay Races	
Baton	T24.5-7; T24 S1(1)
Check marks	T24.4
Indoor events	T48; T44.5; T48.1; T48.4; T55.5
Infringements	T24.6-11; T24.18-21
Medley Relay	T24.14; T24.18; T24.20-21
Relay Records	C31.3.4; C31.16
Takeover zone	T24.3; T24.7; T24.19
Team membership	T24.10-11
UKA Races – 4x300m	T24 S1(2)
Resignation from Club	G2 S3
Rest Periods	T20.10; T20 S1; T39.6; T39 S1
Results	
Announcing	T8
Field Events	T25.21
Official time – hand timing	T19.12
Signing of result cards	C18.4; C35 S1.13
System	T19.21
Road Races	T55
Additional Gender Categories - UK	Appendix 4
Course design, UKA	T55 S1
Course measurement	T55.3
Drinks and refreshment stations	T55.8; T55 S2
Headphones	T55 S5
Race classification, UKA	T55 S3
Records	C31.21
Relays – see Road Relays	
Running with dogs	T55 S6
Safety	T54 S2; T55.7; Appendix 4
Standard distances	T55.1; T55.2 (Note (i))
Start	T55.6
Transponder Timing	T19.24
UKA course measurement certificate validity	T54.3 UKA Note
Road Races UK – See also Endurance Running UKA	Appendix 4
Road Relays	

**Rule references**

Distances, stages	T55.1(Note(i)); C31.21(g)
Records	C31.21
Restriction on entry numbers - UKA	T55.S3
<b>S</b>	
<b>Safety</b>	
Cross-Country	T1; T55.7; Appendix 4
Mountain races	T1; 142 S2; T57.4; T57 S1; Appendix 4
Road Racing	T1; 2 S2 (4); Appendix 4
Track & Field	T1; 120 Note; 32 S2; G2 S4 (7);
Trail Races	T1; T57.4-5; T57 S2; Appendix 4
Schools	C1 S1; G2 S5; T16 S1
Scoring of matches	T13
Second Claim Status	G2 S3-4; G2 S6
<b>Seeding of Track Events</b>	
Indoors	T45.1
Minimum times between rounds	T20.10; T20 S1
One Day Meetings	T20.9
Outdoors	T20.3
Services (HM)	C1 S1; T55 S3
Sex categories	T3.3-6; Appendix 4
<b>Shoes</b>	
Construction	T5.2; T5.5-6
Dimension of spikes	
Indoors	T45
Outdoors	T5.4
Number of spikes	T5.3
Shoe strap	T5.2
<b>Shot Put</b>	
Assistance	T32.4-5
Cartwheeling technique	T33.1(Note)
Circle	T32.6-8
Circle - Leaving	T32.17.1
Failure	T32.14.1-3; T32.16-17
General conditions	T32
Indoors	T52
Implement details	T33.4-5
Implement details: non WA Age Groups	T33 S1
Landing sector	T32.10-12
Measurement of trial	T32.19-20
Stop board	T33.2-3
Valid put	T33.1

*Rule references*

Spikes - see Shoes	
Sponging	T17.15; T54.10; T55.8; T56.7
Start	
Aborting	T16.5
Commands	T16.2
Cross-Country	T56.5
Delay in responding to commands	T16.5.2
False start	T16.6-9
Language of commands	T16.2
Protests	T8.4
Race Walk	T54.8
Reaction time	T15.2
Road Races	T55.6
Split start	T17.5.2
Start line	T16.1
Under 13, Under 15 and Masters' and Schools' Under 17 Age Groups	T16 S1
Start Referee	C18.1
Starter and Recalls – duties	C22; T16.3-5; T18.3
Starter's Assistants – duties	C23; T16.5; T16.8
Starting Blocks	
Construction	T15.1
Foot contact with blocks	T16.3
Positioning within lane	T15.1
Reaction time	T15.2
Restriction of use	T15.1
Start Information System	T15.2; T16.6 (Note)
Starting Blocks: UKA	T15 S1
Steeplechase	
Distances	T23.1; T23.4
Infringements	T23.7
Specification and placing of Hurdles	T23.2-3; T23.5; T23.5 (Note)
Water Jump	T23.2-3; T23.5-7
Clearance	T23.7
Dimensions	T23.6
Disqualification	T23.7
Number	T23.2-3
Steeplechase: UKA Age Groups and Specifications	T23 S1
Stop board	T33.2-3
Students	G2 S5-6
<b>T</b>	
Take-off board	T29.3-4

**Rule references**

Takeover zones	T24.3; T24.7; T24.19-20; 214.5; T48.1; T48.4; T55.5
Team Competition	G2 S1-6; G2 S9; T55 S3
Technical Delegate – duties	C5; T8.1; T19.20 (Note); T20.2; T25.12; T25. 20; T26.8.4; T39.7
Technical Information Centre	C25
Technical Manager	C13; C16; Appendix 3
Technical Officials: UKA	
Accreditation to Level 4	Appendix 3
Appointments	Appendix 3
Event Management Roles	Appendix 3
Firearms Certificates	Appendix 2
Overseas Appointments	Appendix 2
Pathway	Appendix 2
Records of Officials	Appendix 2
Selection of Officials for Major Events	Appendix 3
Technical Officials' Duties	Appendix 3
Tri-Regional and National Officials Groups	Appendix 2
Throwing Events – general conditions	T32
Throwing Events: UKA Safety	T32 S2
Throwing Events: UKA Circle specification	T32.S3
Ties	
Combined Events	T39.12
Horizontal Jumps	T25.22
Throwing Events	T25.22
Track Events	T21
Vertical Jumps	T26.8-9
Time clock	T25.18 (Note (i))
Timekeepers - duties	C21; T19.4-12; T19.22; Appendix 3
Chief Timekeeper Duties	T19.8-9; T19.12
Combined Events	T39.8.2
Reading and recording times	T19.10; T19.11
UK Records	T19 S1
World Records	C31.14.1
Time of competition - change	T25.20
Track Judges' Duties	Appendix 3
Track Measurement	T14
Certification	T2
Inclination	T14.6
Track Measurements: UKA	T14 S1
Trail races	T57
Aid Stations	T57.5

	<i>Rule references</i>
Course	T57.1
Equipment	T57.2
Race conduct	T57.6-8
Safety	T57.4
Start	T57.3
Trail Races: UKA	
Assistance	T57 S3
Competitors' Responsibilities	T57 S2
Race Conditions	T57 S1
Transgender – eligibility	T3.6
Transponder Timing System	T19.24
For Records	C31.14.1
Judge	C13; T19.25
Trials recorded (Field Events)	T4.3 (Note); T25.8
Completion of trials	T25.8
Number of Trials	T25.6
Order of Trials	T25.5
Substitute trials	T25.18
Time allowed for trials	T25.17
UKA: Alteration to order of competing	T25 S1-S2
UKA: Number of Trials	T25 S3
Triple Jump	
Indoors	T51
Landing area	T29.6-7
Leaving	T30.1.6; T30.2
Measurement of jump	T29.8-9
Plasticine indicator board	T29.5
Runway	T29.1-2
Sequence of jumps	T31.1-2
Sleeping leg	T31.2
Take-off board	T29.3-4
Take-off line	T31.3-4
UKA: Under 13s not allowed to compete	T3 S2 (2) (vii)
Wind measurement	T29.10-12
<b>U</b>	
U13, U15, U17, U20 Athletes: see Age Groups: UKA	
Ultra Race Rules: UKA	G9
Umpires - duties	T20; Appendix 3
Unattached Athletes	C1 S2; G2 S1; G2 S3
Universities – see Eligibility to compete	
Uprights	
High Jump	T27.6-7; T27.9; T27.10 (Note)
Pole Vault	T28.1(Note); T28.9; T28.10 (Note)



*Rule references*

<b>V</b>	
Vertical Jumps – General Conditions	T26
Combined Events	T39.8.4
Crossbar	T26.7
Extraneous Forces	T26.10
Failures and Passes	T26.2
Measurement	T26.5-6
Placings	T26.8-9
Starting Height and Height Progression	T26.1-4
Vests – see Clothing	
Victory Ceremony	T5.1
Video recording	T6.3.2; T8.3; T12; T19.24 .6
Video Referee	C18.1; T12
Video Distance Measurement	C28; <a href="#">Appendix 3</a>
<b>W</b>	
Warm-up – see Practice Trials at Competition Area	
Warning and disqualification	
Assistance	T6.2
Race Walking – see Red paddle	
Referee	C18.5
Start	T16.7-8
Watches - Definition	T19.5
Water and sponges	T17.15; T54.10; T55.8;
Water Jump – see Steeplechase	
Wind Gauge	
Certification	T17.10
Horizontal Jumps	
Duration of recording	T29.12
Positioning	T29.11
Reading values	T17.13
Mechanical gauge	T17.9
Operator	C13; C28; <a href="#">Appendix 3</a>
Track Events	
Duration of recording	T17.12
Positioning	T17.10
Reading values	T17.13
Ultrasonic gauge	T17.9
World Indoor Record	C31.13; 263; C35
World U20 Record	C31.2.2.4; C31.3.3; C33; C35
World Records	
Written reports	
Technical Delegate	C5

***Rule references*****Y**

Yellow card: Warning by Referee

C18.5

Yellow flag: Field - Time allowed for trial

T25.18 (Note(i))

Yellow paddle – Race Walking

T54.5

**Z**

Zero control

T19.19

Zero control test for Records

C31.7.3; C31.14.1

Zigzag distribution - Track heats

T20.3

# RULES FOR COMPETITION EFFECTIVE

FROM 1ST APRIL 2020

