

UKA RULES for COMPETITION 2018 – 2020

Supplementary Guidance Notes

Following publication of the 2018 – 2020 Rule Book a number of issues have been identified that were either omitted during printing or require explanation; these are summarised here.

<u>Rule</u>	<u>Comment</u>																		
120	Management and Competition Officials: where the duties described in Rules 121 – 137 do not apply to events held under UKA Rules, those duty descriptions have been deliberately omitted from the UKA Rule Book 2018 – 2020.																		
142.4	The IAAF Rule headed “Failure to Report to the Call Room” includes a cross reference to 129.6 which is mainly applicable to competitions held under IAAF Rules and not UKA Rules. For clarity 129.6 gives authority to the Starter and Starter’s Assistant to “recall or abort the race if any infringement of the Rules is observed”.																		
143.7 & 143	S2 Athlete Bibs in Track & Field Events held under UKA Rules for Competition: Rule 143.7 will take precedence for Jumping Events where one bib may be worn on either the breast or back. For all other Track & Field events two bibs, on the breast and back, are required.																		
144.3(e)	Assistance - exception for UK competitions: For the British Championships, Home Nations U20/U23 Championships and all events holding a UKA Competition Licence and operated under UKA Rules for Competition, it is acceptable for Officials to indicate foot placement in warm-up of the horizontal jumps.																		
144.3(d)	The Use of “Smart Watches” in Competition: “Smart Watches” may be worn by athletes in competition, but their use as a method of communication during competition is prohibited and, if observed, Officials should take appropriate action.																		
162.7	A cross reference equivalent to that applied in Rule 142.4 has been included in 162.7.																		
168.3	The Header for Hurdle Height specifications is misaligned and should read: <table border="1" style="margin-left: 40px;"> <thead> <tr> <th>Distance</th> <th>Men</th> <th>U20 Men</th> <th>U18 Boys</th> <th>Women/U20</th> <th>U18Girls</th> </tr> </thead> <tbody> <tr> <td>110m/100m</td> <td>1.067m</td> <td>0.991m</td> <td>0.914m</td> <td>0.838m</td> <td>0.762m</td> </tr> <tr> <td>400m</td> <td>0.914m</td> <td>0.914m</td> <td>0.838m</td> <td>0.762m</td> <td>0.762m</td> </tr> </tbody> </table>	Distance	Men	U20 Men	U18 Boys	Women/U20	U18Girls	110m/100m	1.067m	0.991m	0.914m	0.838m	0.762m	400m	0.914m	0.914m	0.838m	0.762m	0.762m
Distance	Men	U20 Men	U18 Boys	Women/U20	U18Girls														
110m/100m	1.067m	0.991m	0.914m	0.838m	0.762m														
400m	0.914m	0.914m	0.838m	0.762m	0.762m														

168 S1 **Masters Hurdles Specifications:** Correction of errors in the 2018 – 2020 Rule Book

Age Category	Distance	Number of Hurdles	Height of Hurdles	Distance to 1st Hurdle	Distance between	Distance to finish	Toppling Weights
M60-69	100 m.	10	.840m	12.0m	8.0m	16.0m	2.7kg
M60-69	300 m.	7	.762m	50.0m	35.0m	40.0m	2.7kg
M70-79	80 m.	8	.762m	12.0m	7.0m	19.0m	2.7kg
M70-79	300 m.	7	.686m	50.0m	35.0m	40.0m	2.7kg
M80+	80 m.	8	.686m	12.0m	7.0m	19.0m	2.7kg
M80+	200 m.	5	.686m	20.0m	35.0m	40.0m	2.7kg

170.10 **Relay Teams** IAAF have added a note to this rule that reads:

Note: The relevant Governing Body (or where there is not one, the Organiser), may specify in the regulations for a competition that the number of additional athletes that may be used once a relay team has started in a competition may be a number more than two.

183 S1 **UK Pole Vault Landing Area:** A new supplement to allow a variation in the size of the Pole Vault Landing Area in events held under UKA Rules for Competition, as appeared in UKA Rules 2014 – 2016:

The landing area shall measure not less than 5m x 5m, excluding the two protection pads on either side of the box. This measurement does not include the sloping area behind the box. The sides of the landing area nearest to the box shall be placed 10cm to 15cm from the box and shall slope away from the box at an angle of approximately 45 degrees. (A 30° angle is acceptable on landing areas in use before 1st April 2006). The protective extensions to the landing bed shall be at least 2m in length. The entire landing area shall be covered by a wear sheet, approximately 50mm deep. The minimum depth of the landing area shall be 80cm.

188 S1 **UKA Age Group Shot Specifications**

U13 Boys 3kgs: Minimum Diameter 85mm, Maximum Diameter 110mm
 Masters: World Masters state that the Maximum Diameter for all sizes of Shot, except 2kgs, is 130mm. UKA Rules will continue with the Maximum Diameters published in the 2018 – 2020 Rule Book.

190 Discus Cage Figure 190

Replace the Discus diagram to show the 69° Danger Sector

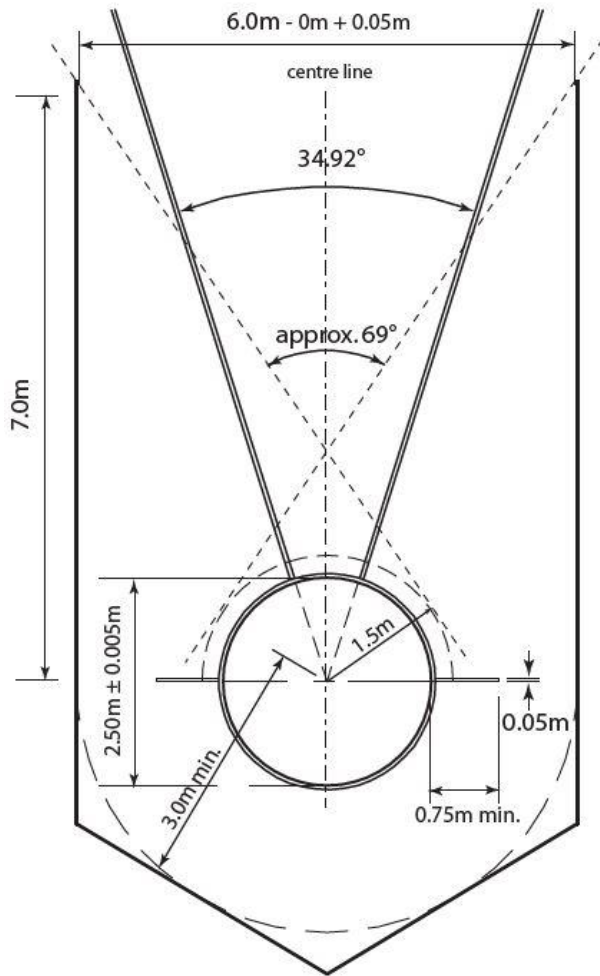

Figure 190 - Cage for Discus Throw only
(with cage dimensions to netting)

192 Hammer Cage Figure 192a

Replace the Hammer cage diagram to show the 53° Danger Sector

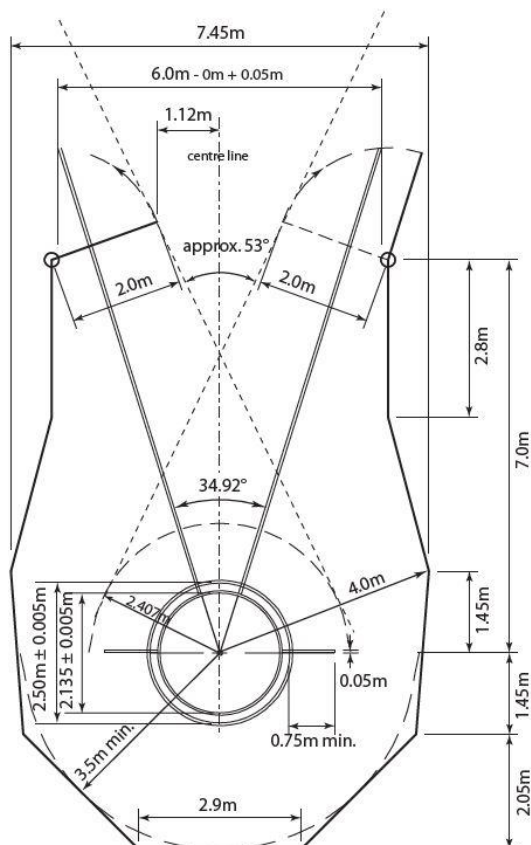

Figure 192a - Cage for Hammer and Discus Throw with concentric circles
(Hammer Throw configuration, with cage dimensions to netting)

193 S1 UKA Age Group Javelin Specifications

Differences between IAAF and UKA specifications for 700g and 500g Javelins have existed for some time as a consequence of the range of Javelins available when the specifications were developed; these differences are now being corrected. Note that there is a probability that IAAF will change the specifications for the 700g Javelin in the next Rule Book.

700g Distance from tip of metal head to centre of gravity: Min 860mm, Max 1000mm
700g Diameter at thickest point: Min 23mm

500g Distance from tip of metal head to centre of gravity: Min 780mm, Max 880mm

It may be necessary to continue allowing some additional tolerances to avoid the danger of non-IAAF standard Javelins being available at some facilities.